

ACROSS

OWNER'S MANUAL

**Keep With Vehicle At All Times.
Contains Important Information
On Safety, Operation & Maintenance.**



Way of Life!

This owner's manual applies to the ACROSS series.

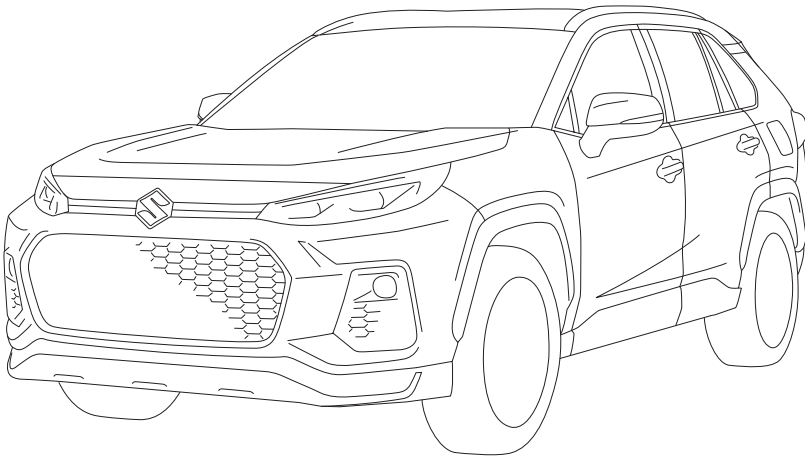







53ZM00001

NOTE: The illustrated model is one of the ACROSS series.

©2020 TOYOTA MOTOR CORPORATION

All rights reserved. This material may not be reproduced or copied, in whole or in part, without the written permission of Toyota Motor Corporation.

BATTERY LABEL SYMBOL MEANINGS

	No smoking, no naked flames, no sparks
	Shield eyes
	Keep away from children
	Battery acid
	Note operating instructions
	Explosive gas

Prepared by
SUZUKI MOTOR CORPORATION

May, 2020

Part No. 99011-53ZM0-01E

TP596

Pictorial index	Search by illustration	
For safety and security	Make sure to read through them (Main topics: Child seat, theft deterrent system)	1
Plug-in hybrid system	Plug-in hybrid system features, charging method, etc. (Main topics: Driving tips, charging methods)	2
Vehicle status information and indicators	Reading driving-related information (Main topics: Meters, multi-information display)	3
Before driving	Opening and closing the doors and windows, adjustment before driving (Main topics: Keys, doors, seats, power windows)	4
Driving	Operations and advice which are necessary for driving (Main topics: Starting hybrid system, refueling)	5
Interior features	Usage of the interior features (Main topics: Air conditioner, storage features)	6
Maintenance and care	Caring for your vehicle and maintenance procedures (Main topics: Interior and exterior, light bulbs)	7
When trouble arises	What to do in case of malfunction and emergency (Main topics: 12-volt battery discharge, flat tire)	8
Vehicle specifications	Vehicle specifications, customizable features (Main topics: Fuel, oil, tire inflation pressure)	9
Index	Search by symptom	
	Search alphabetically	

2 TABLE OF CONTENTS

For your information	6
Reading this manual.....	9
How to search	10
Pictorial index.....	12

1 For safety and security

1-1. For safe use

Before driving.....	30
For safe driving	31
Seat belts	33
SRS airbags.....	37
Exhaust gas precautions	45

1-2. Child safety

Airbag manual on-off system	46
Riding with children.....	47
Child restraint systems	48

1-3. Emergency assistance

eCall.....	62
------------	----

1-4. Theft deterrent system

Immobilizer system	71
Double locking system.....	72
Alarm	73

2 Plug-in hybrid system

2-1. Plug-in hybrid system

Plug-in hybrid system features	78
Plug-in hybrid system precautions	88
Plug-in hybrid vehicle driving tips	93
EV driving range	96

2-2. Charging

Charging equipment	99
--------------------------	----

AC charging cable	102
-------------------------	-----

Locking and unlocking the charging port lid and charging connector.....	114
---	-----

Power sources that can be used	117
--------------------------------------	-----

Charging methods	120
------------------------	-----

Charging tips.....	123
--------------------	-----

Things to know before charging	125
--------------------------------------	-----

How to charge.....	128
--------------------	-----

Using the charging schedule function	136
--	-----

Using the “My Room Mode”	145
--------------------------	-----

When charging cannot be carried out.....	148
--	-----

3 Vehicle status information and indicators

3-1. Instrument cluster

Warning lights and indicators	160
-------------------------------------	-----

Gauges and meters	166
-------------------------	-----

Multi-information display	171
---------------------------------	-----

Energy monitor/consumption screen.....	182
--	-----

4 Before driving

4-1. Key information

Keys.....	188
-----------	-----

4-2. Opening, closing and locking the doors

Side doors.....	191
-----------------	-----

Back door.....	195
----------------	-----

Smart entry & start system	206
----------------------------	-----

4-3. Adjusting the seats
 Front seats249
 Rear seats250
 Head restraints252

4-4. Adjusting the steering wheel and mirrors
 Steering wheel254
 Inside rear view mirror255
 Outside rear view mirrors...256

4-5. Opening, closing the windows
 Power windows258

5 Driving

5-1. Before driving
 Driving the vehicle262
 Cargo and luggage268
 Trailer towing270

5-2. Driving procedures
 Power (ignition) switch279
 Hybrid transmission283
 Turn signal lever287
 Parking brake288
 Brake Hold291

5-3. Operating the lights and wipers
 Headlight switch294
 AHB (Automatic High Beam)296
 Fog light switch299
 Windshield wipers and washer300
 Rear window wiper and washer302

5-4. Refueling
 Opening the fuel tank cap...304

5-5. Using the driving support systems
 Safety Sense306
 PCS (Pre-Collision System)316
 LTA (Lane Tracing Assist) ...323
 RSA (Road Sign Assist)333
 Dynamic radar cruise control with full-speed range337
 BSM (Blind Spot Monitor) ...349
 Parking assist-sensor369
 PKSB (Parking Support Brake)375
 Parking Support Brake function (static objects)379
 Parking Support Brake function (rear-crossing vehicles)384
 Driving mode select switch .388
 Trail Mode390
 GPF (Gasoline Particulate Filter) system391
 Driving assist systems392

5-6. Driving tips
 Winter driving tips399
 Utility vehicle precautions ...401

6 Interior features

6-1. Using the air conditioning system and defogger
 Automatic air conditioning system.....406
 Remote Air Conditioning System413



4 TABLE OF CONTENTS

- Heated steering wheel/seat heaters.....**415**
- 6-2. Using the interior lights**
 - Interior lights list.....**417**
- 6-3. Using the storage features**
 - List of storage features**420**
 - Luggage compartment features**424**
- 6-4. Using the other interior features**
 - Other interior features.....**427**

7 Maintenance and care

- 7-1. Maintenance and care**
 - Cleaning and protecting the vehicle exterior**432**
 - Cleaning and protecting the vehicle interior**435**
- 7-2. Maintenance**
 - Maintenance requirements **438**
- 7-3. Do-it-yourself maintenance**
 - Do-it-yourself service precautions**440**
 - Hood**442**
 - Positioning a floor jack.....**443**
 - Engine compartment.....**445**
 - 12-volt battery**450**
 - Tires**452**
 - Tire inflation pressure**471**
 - Wheels**472**
 - Air conditioning filter**473**
 - Cleaning the DC/DC Converter air intake vent and filter**477**
 - Wiper insert replacement....**481**

- Electronic key battery**484**
- Checking and replacing fuses**486**
- Light bulbs**489**

8 When trouble arises

8-1. Essential information

- Emergency flashers**500**
- If your vehicle has to be stopped in an emergency**500**
- If the vehicle is trapped in rising water**501**

8-2. Steps to take in an emergency

- If your vehicle needs to be towed**503**
- If you think something is wrong**506**
- If a warning light turns on or a warning buzzer sounds.....**508**
- If a warning message is displayed**518**
- If you have a flat tire**522**
- If the hybrid system will not start**530**
- If you lose your keys**531**
- If the fuel filler door cannot be opened.....**532**
- If the electronic key does not operate properly**533**
- If the 12-volt battery is discharged.....**535**
- If your vehicle overheats.....**540**
- If the vehicle becomes stuck**543**

9 Vehicle specifications

9-1. Specifications

Maintenance data (fuel, oil level, etc.).....**546**

Fuel information**554**

9-2. Customization

Customizable features**555**

9-3. Initialization

Items to initialize**567**

Index

What to do if... (Troubleshooting)**570**

Alphabetical Index**573**

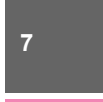

For your information

Main Owner's Manual

Please note that this manual applies to all models and explains all equipment, including options. Therefore, you may find some explanations for equipment not installed on your vehicle.

All specifications provided in this manual are current at the time of printing. However, because of the Suzuki policy of continual product improvement, we reserve the right to make changes at any time without notice.

Depending on specifications, the vehicle shown in the illustrations may differ from your vehicle in terms of equipment.

Accessories, spare parts and modification of your vehicle

Both genuine Suzuki and a wide variety of other spare parts and accessories for Suzuki vehicles are currently available in the market. Should it be determined that any of the genuine Suzuki parts or accessories supplied with the vehicle need to be replaced, Suzuki recommends that genuine Suzuki parts or accessories, be used to replace them. Other parts or accessories of matching quality can also be used. Suzuki cannot accept any liability or

guarantee spare parts and accessories which are not genuine Suzuki products, nor for replacement or installation involving such parts. In addition, damage or performance problems resulting from the use of non-genuine Suzuki spare parts or accessories may not be covered under warranty.

Installation of an RF-transmitter system

The installation of an RF-transmitter system in your vehicle could affect electronic systems such as:

- Hybrid system
- Multiport fuel injection system/sequential multiport fuel injection system
- Safety Sense
- Cruise control system
- Anti-lock brake system
- SRS airbag system
- Seat belt pretensioner system

Be sure to check with a SUZUKI dealer or a qualified workshop for precautionary measures or special instructions regarding installation of an RF-transmitter system.

Further information regarding frequency bands, power levels, antenna positions and installation provisions for the installation of RF-transmitters, is available on request at a SUZUKI dealer or a qualified workshop.

High voltage parts and cables on the hybrid vehicles emit approximately the same amount of electromagnetic waves as the conventional gasoline powered vehicles or home electronic appliances despite of their electromagnetic shielding.

Unwanted noise may occur in the reception of the radio frequency transmitter (RF-transmitter).

Vehicle data recording

The vehicle is equipped with sophisticated computers that will record certain data, such as:

- Engine speed/Electric motor speed (traction motor speed)
- Accelerator status
- Brake status
- Vehicle speed
- Operation status of the driving assist systems
- Hybrid battery (traction battery) status

The recorded data varies according to the vehicle grade level, options and destinations with which it is equipped.

These computers do not record conversations or sounds, and only record images outside of the vehicle in certain situations.

● Data usage

Suzuki may use the data recorded in this computer to diagnose malfunctions, conduct research and development, and improve quality.

Suzuki will not disclose the recorded data to a third party except:

- With the consent of the vehicle owner or with the consent of the lessee if the vehicle is leased
- In response to an official request by the police, a court of law or a government agency
- For use by Suzuki in a lawsuit
- For research purposes where the data is not tied to a specific vehicle or vehicle owner

Scrapping of your vehicle

The SRS airbag and seat belt pretensioner devices in your vehicle contain explosive chemicals. If the vehicle is scrapped with the airbags and seat belt pretensioners left as they are, this may cause an accident such as fire. Be sure to have the systems of the SRS airbag and seat belt pretensioner removed and disposed of by a qualified service shop or a SUZUKI dealer or a qualified workshop, before you scrap your vehicle.

**WARNING****■ General precautions while driving**

Driving under the influence: Never drive your vehicle when under the influence of alcohol or drugs that have impaired your ability to operate your vehicle. Alcohol and certain drugs delay reaction time, impair judgment and reduce coordination, which could lead to an accident that could result in death or serious injury.

Defensive driving: Always drive defensively. Anticipate mistakes that other drivers or pedestrians might make and be ready to avoid accidents.

Driver distraction: Always give your full attention to driving. Anything that distracts the driver, such as adjusting controls, talking on a cellular phone or reading can result in a collision with resulting death or serious injury to you, your occupants or others.

■ General precaution regarding children's safety



Never leave children unattended in the vehicle, and never allow children to have or use the key.

Children may be able to start the vehicle or shift the vehicle into neutral. There is also a danger that children may injure themselves by playing with the side windows or other features of the vehicle. In addition, heat build-up or extremely cold temperatures inside the vehicle can be fatal to children.

Reading this manual



Explains symbols used in this manual

Symbols in this manual

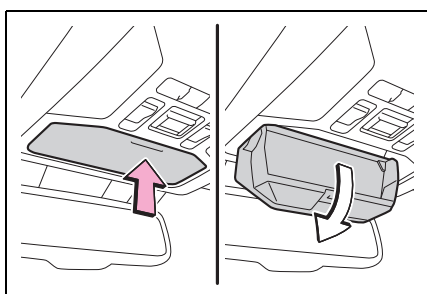

Symbols	Meanings
	WARNING: Explains something that, if not obeyed, could cause death or serious injury to people.
	NOTICE: Explains something that, if not obeyed, could cause damage to or a malfunction in the vehicle or its equipment.
1 2 3...	Indicates operating or working procedures. Follow the steps in numerical order.

Symbols in illustrations

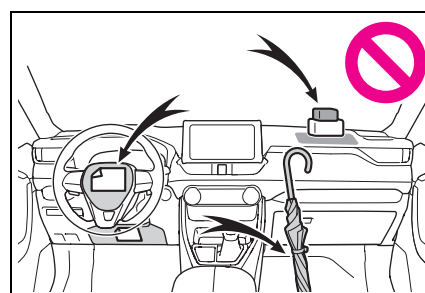

Symbols	Meanings
	Indicates the action (pushing, turning, etc.) used to operate switches and other devices.
	Indicates the outcome of an operation (e.g. a lid opens).



Symbols	Meanings
	Indicates the component or position being explained.
	Means Do not, Do not do this, or Do not let this happen.

How to search**■ Searching by name**

- Alphabetical index: →P.573

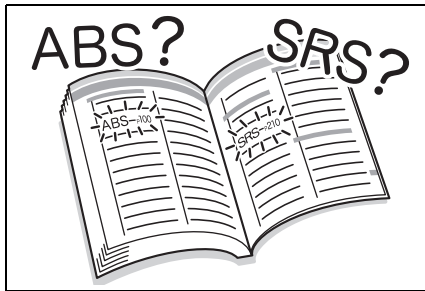
**■ Searching by installation position**

- Pictorial index: →P.12

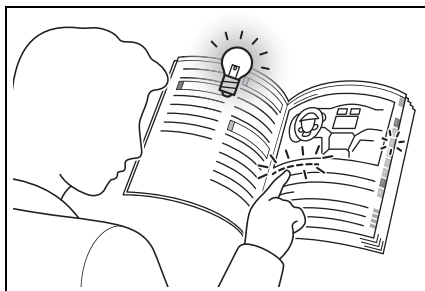
**■ Searching by symptom or sound**

- What to do if... (Troubleshooting): →P.570

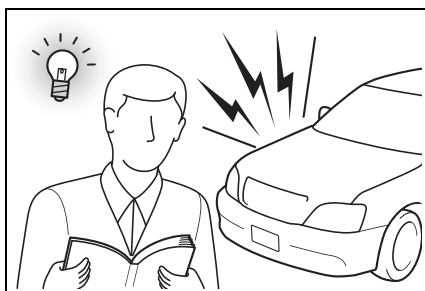
**■ Searching by title**

- Table of contents: →P.2

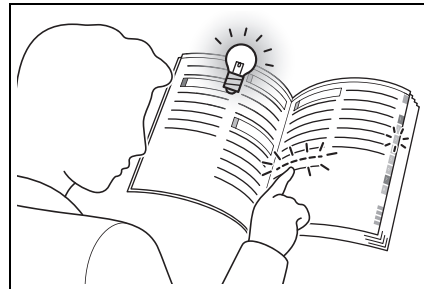

Pictorial index

■ Exterior

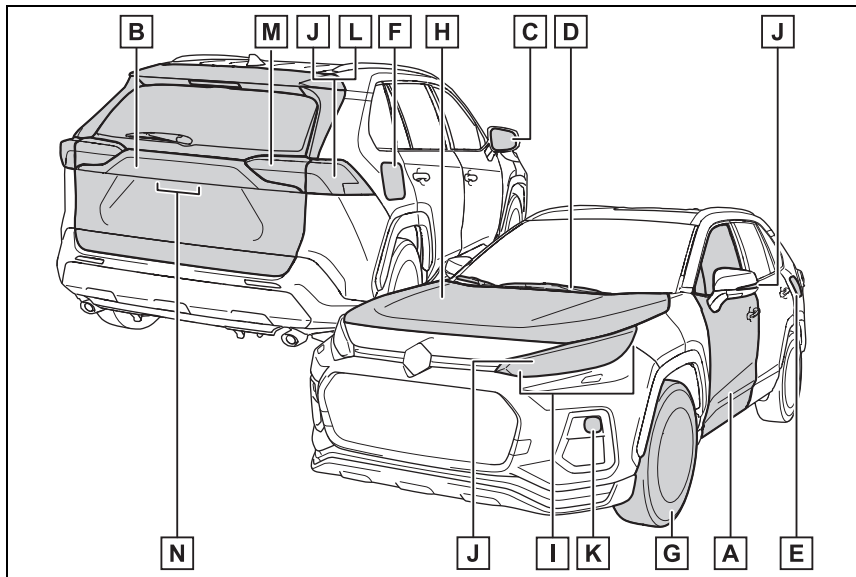

- A Side doorsP.191**
 - Locking/unlockingP.191
 - Opening/closing the side windows.....P.258
 - Locking/unlocking by using the mechanical key P.533
 - Warning messagesP.518
- B Back doorP.195**
 - Locking/unlockingP.196
 - Opening from inside the cabin^{*1}P.197
 - Opening from outside.....P.197
 - Warning messagesP.518
- C Outside rear view mirrorsP.256**
 - Adjusting the mirror angleP.256
 - Folding the mirrorsP.257
 - Defogging the mirrorsP.408
- D Windshield wipersP.300**

Precautions against winter season	P.399
To prevent freezing (windshield wiper de-icer).....	P.411
Precautions against car wash	P.433
Replacing the wiper insert.....	P.481
E Fuel filler door	P.304
Refueling method	P.304
Fuel type/fuel tank capacity	P.548
F Charging port	P.99
Charging method	P.120
G Tires	P.452
Tire size/inflation pressure	P.552
Winter tires/tire chain	P.399
Checking/rotation/tire pressure warning system	P.452
Coping with flat tires.....	P.522
H Hood.....	P.442
Opening	P.442
Engine oil	P.549
Coping with overheat	P.540
Warning messages	P.518

Light bulbs of the exterior lights for driving
(Replacing method: P.489, Watts: P.553)

I Headlights/front position lights/daytime running lights	P.294
J Turn signal lights	P.287
K Front fog lights.....	P.299
L Tail lights	P.294
M Tail lights	P.294
Back-up lights	
Shifting the shift lever to R	P.283
Rear fog light*2	P.299

14 Pictorial index

N License plate lights.....P.294

*1: If equipped

*2: It may be located on the opposite side depending on the target region.

■ Instrument panel (Left-hand drive vehicles)

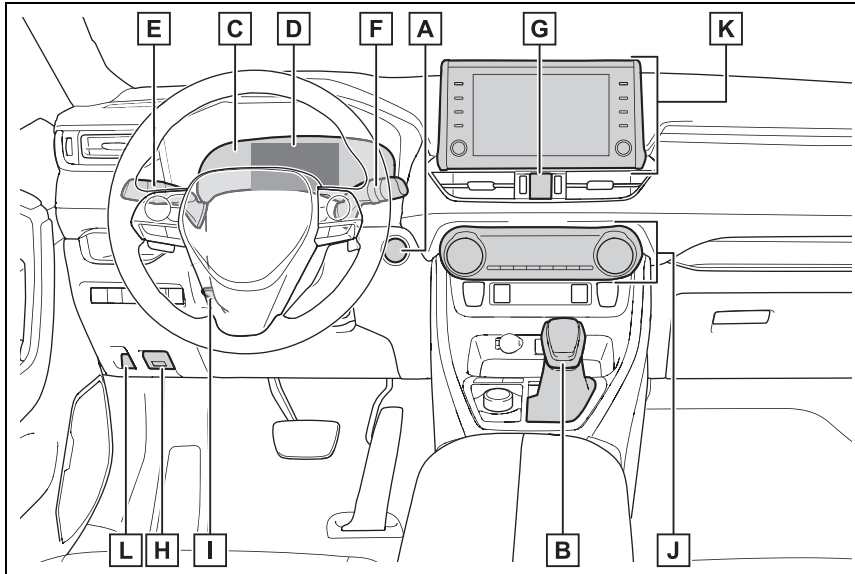

- A Power switch**P.279
 - Starting the hybrid system/changing the modes P.279, 282
 - Emergency stop of the hybrid systemP.500
 - When the hybrid system will not start P.530
 - Warning messages P.518
- B Shift lever**.....P.283
 - Changing the shift position.....P.284
 - Precautions against towingP.503
 - When the shift lever does not move.....P.285
- C Meters**P.166
 - Reading the meters/adjusting the instrument cluster lightP.166, 170
 - Warning lights/indicator lightsP.160
 - When the warning lights come on.....P.508
- D Multi-information display**P.171
 - DisplayP.171

Energy monitor.....	P.182
When the warning messages are displayed	P.518
E Turn signal lever	P.287
Headlight switch	P.294
Headlights/front position lights/tail lights/ license plate lights/daytime running lights.....	P.294
Front fog lights/rear fog light	P.299
F Windshield wiper and washer switch	P.300
Rear window wiper and washer switch	P.302
Usage.....	P.300, 302
Adding washer fluid.....	P.449
Warning messages	P.518
G Emergency flasher switch.....	P.500
H Hood lock release lever.....	P.442
I Tilt and telescopic steering lock release lever.....	P.254
Adjustment	P.254
J Air conditioning system	P.406
Usage.....	P.406
Rear window defogger	P.408
K Audio system*	
L Fuel filler door opener switch	P.305

*: Refer to "Multimedia Owner's Manual".

■ Switches (Left-hand drive vehicles)

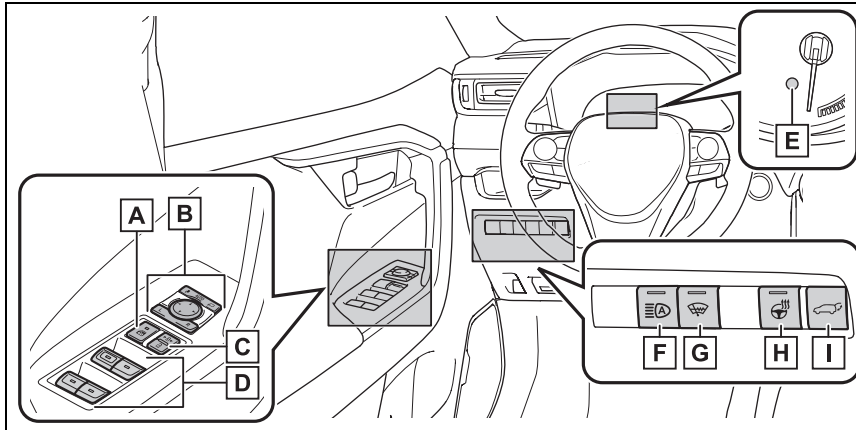

- A** Window lock switchP.260
- B** Outside rear view mirror switchesP.256
- C** Door lock switchesP.194
- D** Power window switchesP.258
- E** “ODO TRIP” switchP.170
- F** Automatic High Beam switchP.296
- G** Windshield wiper de-icer switchP.411
- H** Heated steering wheel switchP.416
- I** Power back door switchP.197

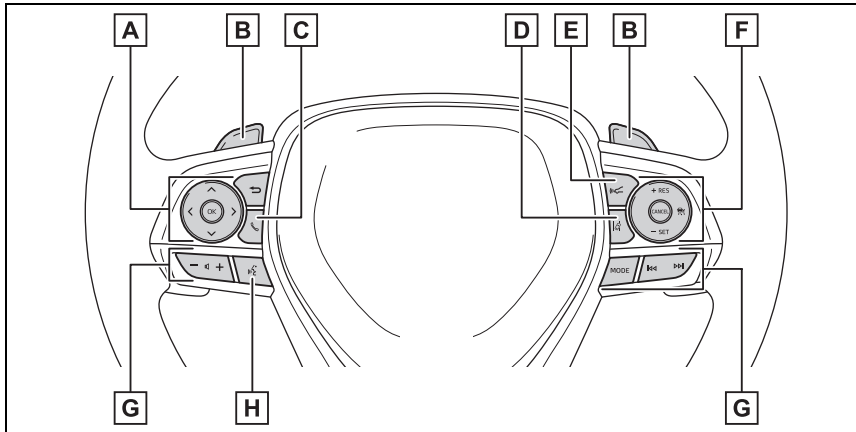

- A** Meter control switchesP.172
- B** Paddle shift switchesP.285
- C** Phone switch*
- D** LTA (Lane Tracing Assist) switchP.323
- E** Vehicle-to-vehicle distance switch.....P.342
- F** Cruise control switches
 Dynamic radar cruise control with full-speed rangeP.337
- G** Audio remote control switches*
- H** Talk switch*

*: Refer to "Multimedia Owner's Manual".

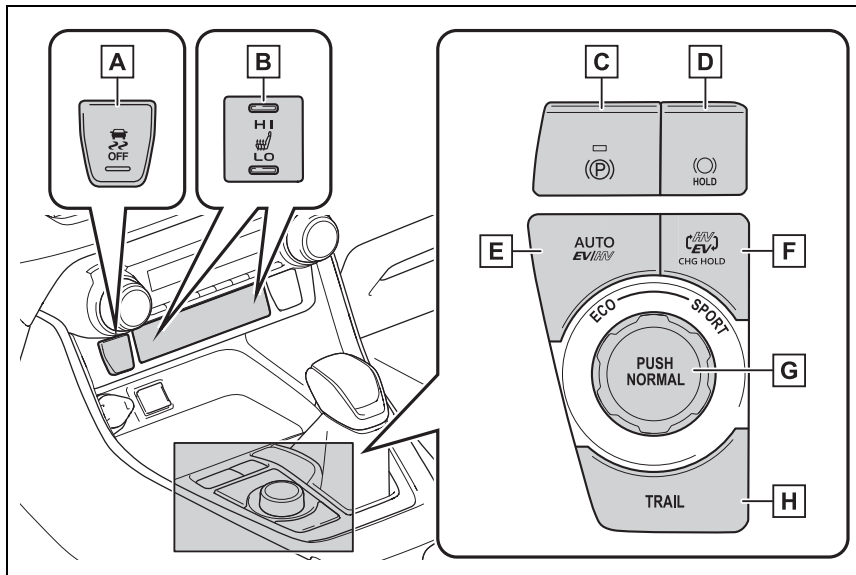

A	VSC OFF switch	P.394
B	Front seat heater switches	P.416
C	Parking brake switch	P.288
	Applying/releasing.....	P.288
	Precautions against winter season	P.400
	Warning buzzer/message	P.514, 518
D	Brake hold switch	P.291
E	AUTO EV/HV mode switch	P.80
F	EV/HV mode selection switch	P.80
G	Driving mode select switch	P.388
H	Trail Mode switch	P.390

■ Interior (Left-hand drive vehicles)

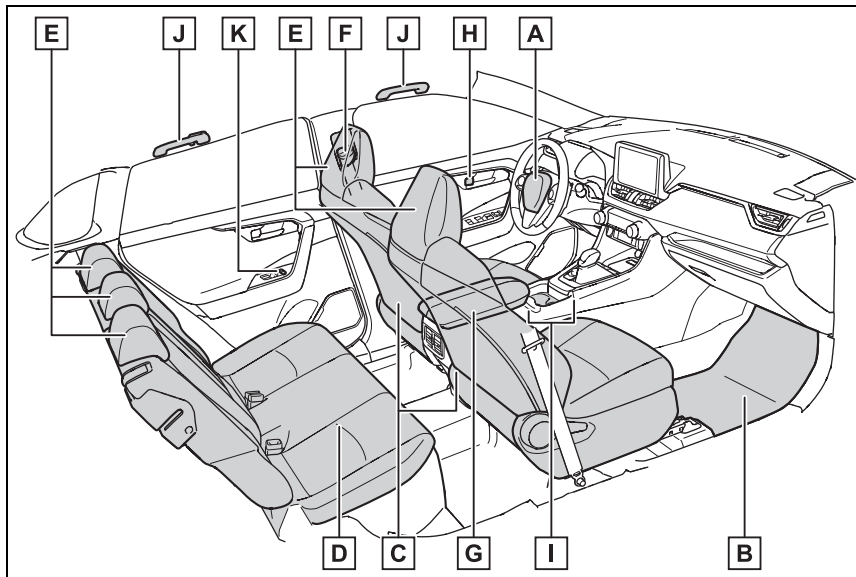

A	SRS airbags	P.37
B	Floor mats	P.30
C	Front seats	P.249
D	Rear seats	P.250
E	Head restraints	P.252
F	Seat belts	P.33
G	Console box	P.421
H	Inside lock buttons	P.194
I	Cup holders	P.422
J	Assist grips	P.429
K	Rear seat heater switches	P.416

■ Ceiling (Left-hand drive vehicles)

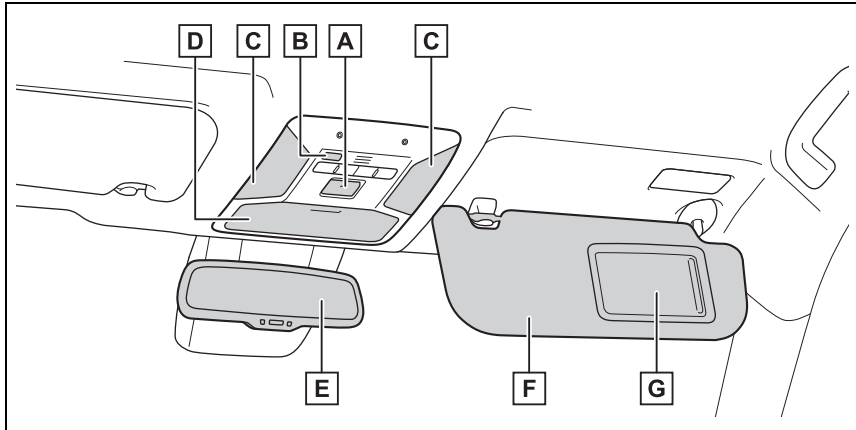

- A** "SOS" button.....P.62
- B** Intrusion sensor and tilt sensor cancel switch.....P.74
- C** Interior lights*¹P.418
Personal lightsP.418
- D** Auxiliary boxP.423
- E** Inside rear view mirrorP.255
- F** Sun visors*²P.427
- G** Vanity mirrors.....P.427

*¹: The illustration shows the front, but they are also equipped in the rear.

*²: NEVER use a rearward facing child restraint on a seat protected by an ACTIVE AIRBAG in front of it, DEATH or SERIOUS INJURY to the CHILD can occur. (→P.51)



■ Instrument panel (Right-hand drive vehicles)

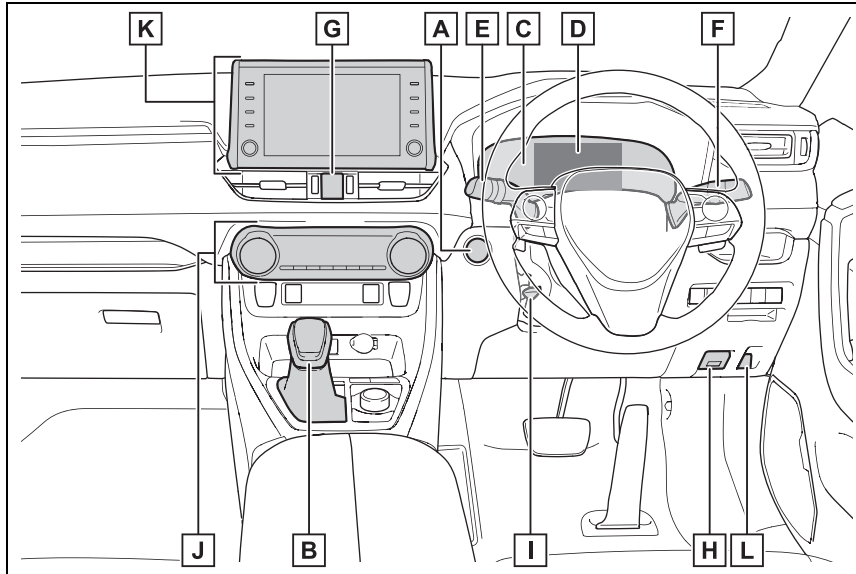

- A Power switch**P.279
 Starting the hybrid system/changing the modes P.279, 282
 Emergency stop of the hybrid systemP.500
 When the hybrid system will not start P.530
 Warning messagesP.518
- B Shift lever**.....P.283
 Changing the shift position.....P.284
 Precautions against towingP.503
 When the shift lever does not move.....P.285
- C Meters**P.166
 Reading the meters/adjusting the instrument cluster lightP.166, 170
 Warning lights/indicator lightsP.160
 When the warning lights come on.....P.508
- D Multi-information display**P.171
 DisplayP.171

Energy monitor.....	P.182
When the warning messages are displayed	P.518
E Turn signal lever	P.287
Headlight switch	P.294
Headlights/front position lights/tail lights/ license plate lights/daytime running lights.....	P.294
Front fog lights/rear fog light	P.299
F Windshield wiper and washer switch	P.300
Rear window wiper and washer switch	P.302
Usage.....	P.300, 302
Adding washer fluid.....	P.449
Warning messages	P.518
G Emergency flasher switch.....	P.500
H Hood lock release lever.....	P.442
I Tilt and telescopic steering control lever	P.254
Adjustment	P.254
J Air conditioning system	P.406
Usage.....	P.406
Rear window defogger	P.408
K Audio system*	
L Fuel filler door opener switch	P.305

*: Refer to "Multimedia Owner's Manual".

■ Switches (Right-hand drive vehicles)

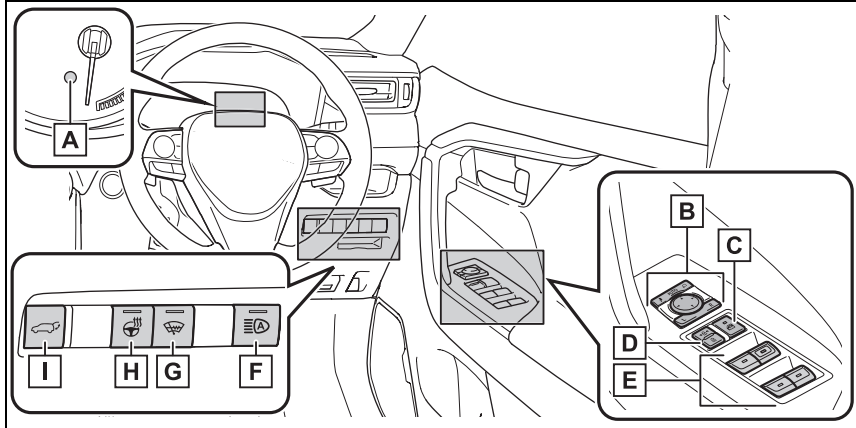

- A** “ODO TRIP” switchP.170
- B** Outside rear view mirror switchesP.256
- C** Window lock switchP.260
- D** Door lock switchesP.194
- E** Power window switchesP.258
- F** Automatic High Beam switchP.296
- G** Windshield wiper de-icer switchP.411
- H** Heated steering wheel switchP.416
- I** Power back door switchP.197

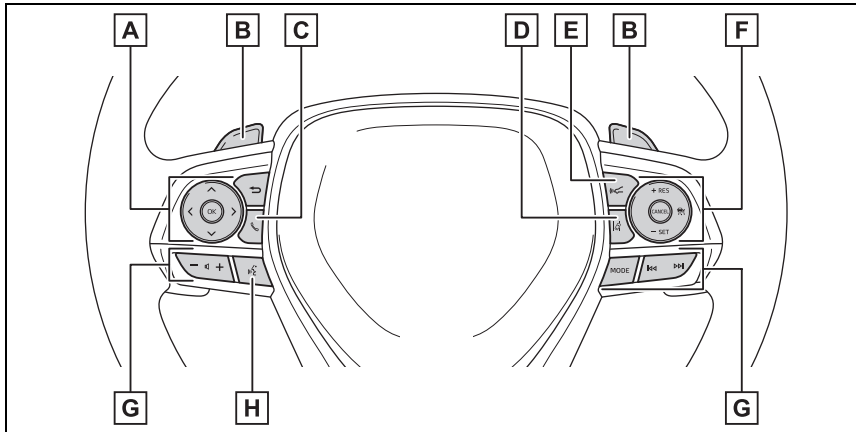

- A** Meter control switchesP.172
- B** Paddle shift switchesP.285
- C** Phone switch*
- D** LTA (Lane Tracing Assist) switchP.323
- E** Vehicle-to-vehicle distance switch.....P.342
- F** Cruise control switches
 Dynamic radar cruise control with full-speed rangeP.337
- G** Audio remote control switches*
- H** Talk switch*

*: Refer to "Multimedia Owner's Manual".

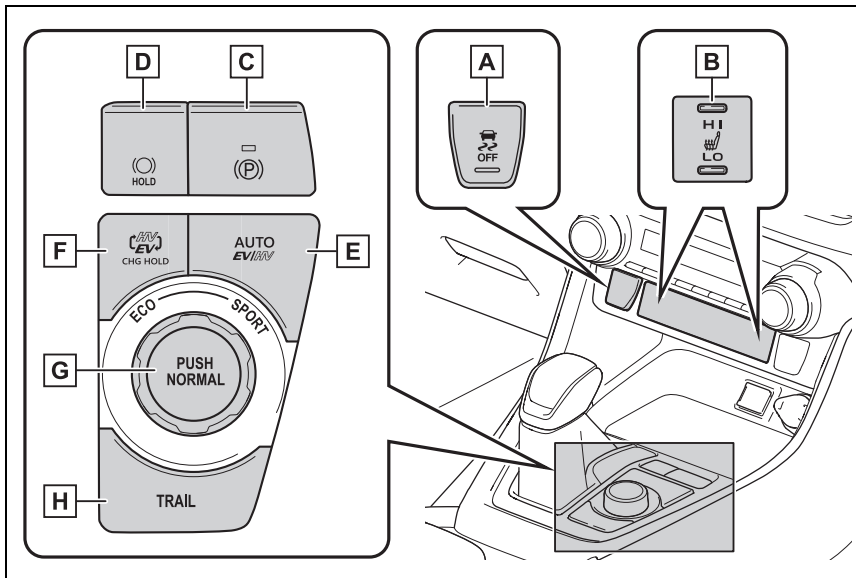

A	VSC OFF switch	P.394
B	Front seat heater switches	P.416
C	Parking brake switch	P.288
	Applying/releasing.....	P.288
	Precautions against winter season	P.400
	Warning buzzer/message	P.514, 518
D	Brake hold switch	P.291
E	AUTO EV/HV mode switch	P.80
F	EV/HV mode selection switch	P.80
G	Driving mode select switch	P.388
H	Trail Mode switch	P.390

■ Interior (Right-hand drive vehicles)

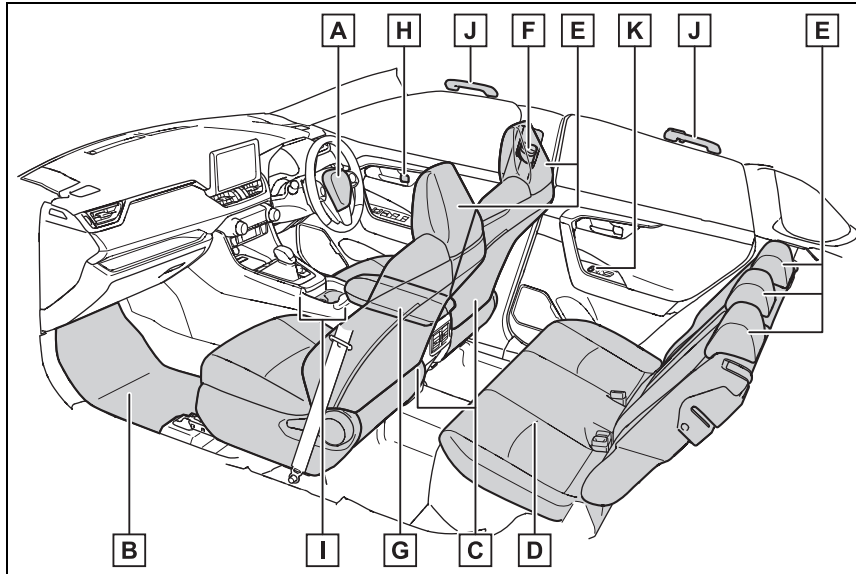

A	SRS airbags	P.37
B	Floor mats	P.30
C	Front seats	P.249
D	Rear seats	P.250
E	Head restraints	P.252
F	Seat belts	P.33
G	Console box	P.421
H	Inside lock buttons	P.194
I	Cup holders	P.422
J	Assist grips	P.429
K	Rear seat heater switches	P.416

■ Ceiling (Right-hand drive vehicles)

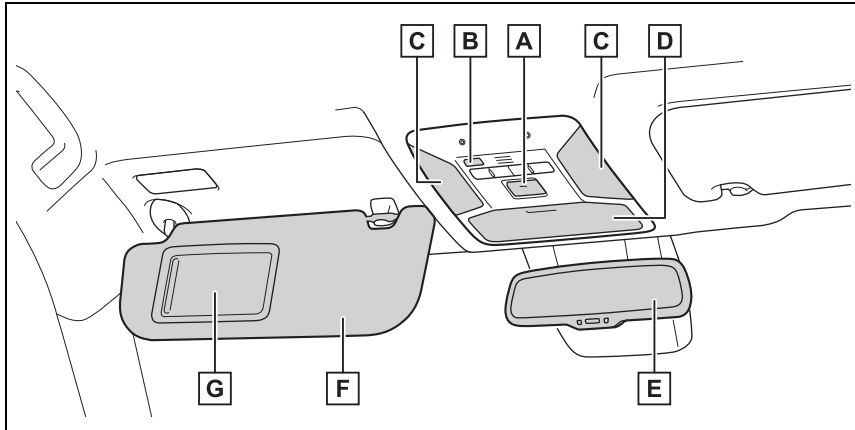

- A** "SOS" button.....P.62
- B** Intrusion sensor and tilt sensor cancel switch.....P.74
- C** Interior lights*¹P.418
Personal lightsP.418
- D** Auxiliary boxP.423
- E** Inside rear view mirrorP.255
- F** Sun visors*²P.427
- G** Vanity mirrors.....P.427

*¹: The illustration shows the front, but they are also equipped in the rear.

*²: NEVER use a rearward facing child restraint on a seat protected by an ACTIVE AIRBAG in front of it, DEATH or SERIOUS INJURY to the CHILD can occur.
(→P.51)



For safety and security

1

- 1-1. For safe use**
 - Before driving **30**
 - For safe driving **31**
 - Seat belts **33**
 - SRS airbags **37**
 - Exhaust gas precautions **45**
- 1-2. Child safety**
 - Airbag manual on-off system
..... **46**
 - Riding with children **47**
 - Child restraint systems **48**
- 1-3. Emergency assistance**
 - eCall **62**
- 1-4. Theft deterrent system**
 - Immobilizer system **71**
 - Double locking system **72**
 - Alarm **73**

Before driving

Observe the following before starting off in the vehicle to ensure safety of driving.

Installing floor mats

Use only floor mats designed specifically for vehicles of the same model and model year as your vehicle. Fix them securely in place onto the carpet.

- 1 Insert the retaining hooks (clips) into the floor mat eyelets.

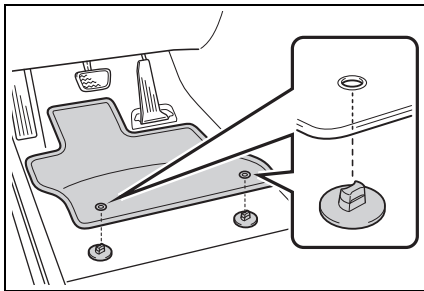

- 2 Turn the upper knob of each retaining hook (clip) to secure the floor mats in place.

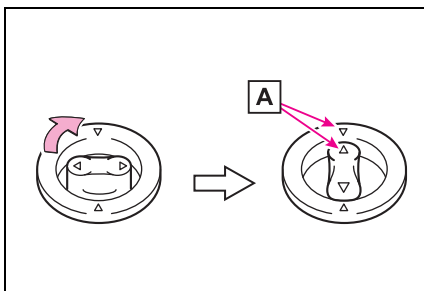

Always align the \triangle marks **A**.

The shape of the retaining hooks (clips) may differ from that shown in the illus-

tration.

WARNING

Observe the following precautions. Failure to do so may cause the driver's floor mat to slip, possibly interfering with the pedals while driving. An unexpectedly high speed may result or it may become difficult to stop the vehicle. This could lead to an accident, resulting in death or serious injury.

When installing the driver's floor mat

- Do not use floor mats designed for other models or different model year vehicles, even if they are Suzuki Genuine floor mats.
- Only use floor mats designed for the driver's seat.
- Always install the floor mat securely using the retaining hooks (clips) provided.
- Do not use two or more floor mats on top of each other.
- Do not place the floor mat bottom-side up or upside-down.

Before driving

- Check that the floor mat is securely fixed in the correct place with all the provided retaining hooks (clips). Be especially careful to perform this check after cleaning the floor.

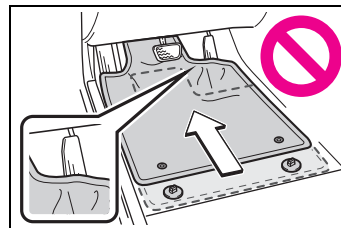

**WARNING**

- With the hybrid system stopped and the shift lever in P, fully depress each pedal to the floor to make sure it does not interfere with the floor mat.

For safe driving

For safe driving, adjust the seat and mirror to an appropriate position before driving.

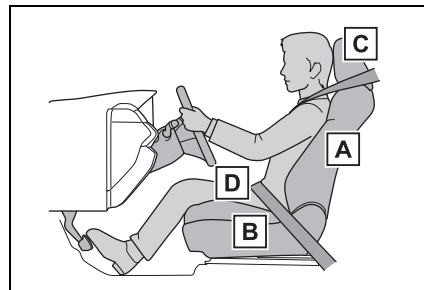
Correct driving posture

- A** Adjust the angle of the seatback so that you are sitting straight up and so that you do not have to lean forward to steer. (→P.249)
- B** Adjust the seat so that you can depress the pedals fully and so that your arms bend slightly at the elbow when gripping the steering wheel. (→P.249)
- C** Lock the head restraint in place with the center of the head restraint closest to the top of your ears. (→P.252)
- D** Wear the seat belt correctly. (→P.34)

**WARNING**

Observe the following precautions. Failure to do so may result in death or serious injury.

- Do not adjust the position of the driver's seat while driving. Doing so could cause the driver to lose control of the vehicle.
- Do not place a cushion between the driver or passenger and the seat-back. A cushion may prevent correct posture from being achieved, and reduce the effectiveness of the seat belt and head restraint.
- Do not place anything under the front seats. Objects placed under the front seats may become jammed in the seat tracks and stop the seat from locking in place. This may lead to an accident and the adjustment mechanism may also be damaged.
- Always observe the legal speed limit when driving on public roads.
- When driving over long distances, take regular breaks before you start to feel tired. Also, if you feel tired or sleepy while driving, do not force yourself to continue driving and take a break immediately.

Adjusting the mirrors

Make sure that you can see backward clearly by adjusting the inside rear view mirror and outside rear view mirrors properly. (→P.255, 256)

Correct use of the seat belts

Make sure that all occupants are wearing their seat belts before driving the vehicle. (→P.34)

Use a child restraint system appropriate for the child until the child becomes large enough to properly wear the vehicle's seat belt.

(→P.48)

Seat belts

Make sure that all occupants are wearing their seat belts before driving the vehicle.

WARNING

Observe the following precautions to reduce the risk of injury in the event of sudden braking, sudden swerving or an accident.

Failure to do so may cause death or serious injury.

■ Wearing a seat belt

- Ensure that all passengers wear a seat belt.
- Always wear a seat belt properly.
- Each seat belt should be used by one person only. Do not use a seat belt for more than one person at once, including children.
- Suzuki recommends that children be seated in the rear seat and always use a seat belt and/or an appropriate child restraint system.
- To achieve a proper seating position, do not recline the seat more than necessary. The seat belt is most effective when the occupants are sitting up straight and well back in the seats.
- Do not wear the shoulder belt under your arm.
- Always wear your seat belt low and snug across your hips.

■ Pregnant women

Obtain medical advice and wear the seat belt in the proper way. (→P.34)

Women who are pregnant should position the lap belt as low as possible over the hips in the same manner as other occupants, extending the shoulder belt completely over the shoulder and avoiding belt contact with the rounding of the abdominal area.

If the seat belt is not worn properly, not only the pregnant woman, but also the fetus could suffer death or serious injury as a result of sudden braking or a collision.

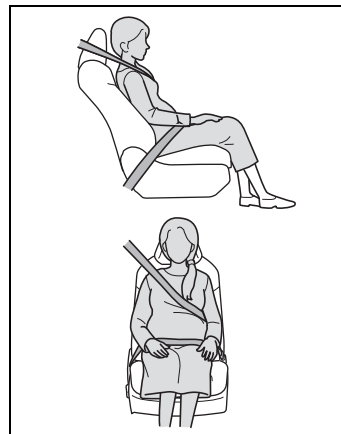

■ People suffering illness

Obtain medical advice and wear the seat belt in the proper way. (→P.34)

■ When children are in the vehicle

→P.59

■ Seat belt damage and wear

- Do not damage the seat belts by allowing the belt, plate, or buckle to be jammed in the door.

WARNING

- Inspect the seat belt system periodically. Check for cuts, fraying, and loose parts. Do not use a damaged seat belt until it is replaced. Damaged seat belts cannot protect an occupant from death or serious injury.
- Ensure that the belt and plate are locked and the belt is not twisted. If the seat belt does not function correctly, immediately contact a SUZUKI dealer or a qualified workshop.
- Replace the seat assembly, including the belts, if your vehicle has been involved in a serious accident, even if there is no obvious damage.
- Do not attempt to install, remove, modify, disassemble or dispose of the seat belts. Have any necessary repairs carried out by a SUZUKI dealer or a qualified workshop. Inappropriate handling may lead to incorrect operation.

Correct use of the seat belts

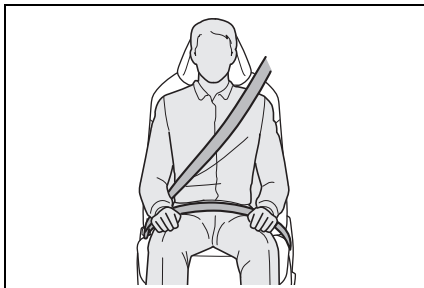

- Extend the shoulder belt so that it comes fully over the shoulder, but does not come into contact with the neck or slide off the shoulder.
- Position the lap belt as low as

possible over the hips.

- Adjust the position of the seat-back.
Sit up straight and well back in the seat.
- Do not twist the seat belt.

Child seat belt usage

The seat belts of your vehicle were principally designed for persons of adult size.

- Use a child restraint system appropriate for the child, until the child becomes large enough to properly wear the vehicle's seat belt. (→P.48)
- When the child becomes large enough to properly wear the vehicle's seat belt, follow the instructions regarding seat belt usage. (→P.33)

Seat belt regulations

If seat belt regulations exist in the country where you reside, please contact a SUZUKI dealer or a qualified workshop for seat belt replacement or installation.

Fastening and releasing the seat belt

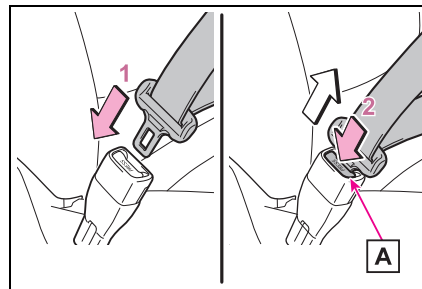

- 1 To fasten the seat belt, push the plate into the buckle until a click sound is heard.
- 2 To release the seat belt, press the release button **A**.

■ Emergency locking retractor (ELR)

The retractor will lock the belt during a sudden stop or on impact. It may also lock if you lean forward too quickly. A slow, easy motion will allow the belt to extend so that you can move around fully.

Adjusting the seat belt shoulder anchor height (front seats)

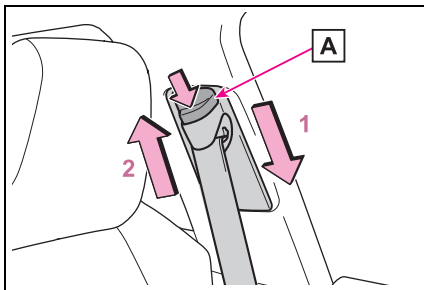

- 1 Push the seat belt shoulder anchor down while pressing the release button **A**.
- 2 Push the seat belt shoulder anchor up while pressing the release button **A**.

Move the height adjuster up and down as needed until you hear a click.

⚠ WARNING

■ Adjustable shoulder anchor

Always make sure the shoulder belt is positioned across the center of your shoulder. The belt should be kept away from your neck, but not falling off your shoulder. Failure to do so could reduce the amount of protection in an accident and cause death or serious injuries in the event of a sudden stop, sudden swerve or accident.

Seat belt pretensioners (front and outboard rear seats)

The pretensioners help the seat belts to quickly restrain the occupants by retracting the seat belts when the vehicle is subjected to certain types of severe frontal or side collision.

The pretensioners do not activate in the event of a minor frontal impact, a minor side impact, a rear impact or a vehicle rollover.

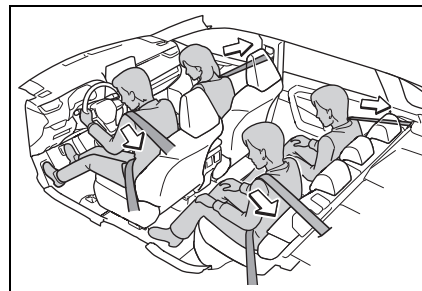

■ Replacing the belt after the pretensioner has been activated

If the vehicle is involved in multiple collisions, the pretensioner will activate for the first collision, but will not activate for the second or subsequent collisions.

■ PCS-linked seat belt pretensioner control

If the PCS (Pre-Collision System) determines that the possibility of a collision with a vehicle is high, the seat belt pretensioners will be prepared to operate.

**WARNING****■ Seat belt pretensioners**

If the pretensioner has activated, the SRS warning light will come on. In that case, the seat belt cannot be used again and must be replaced at a SUZUKI dealer or a qualified workshop.

Failure to do so may cause death or serious injury.

SRS airbags

The SRS airbags inflate when the vehicle is subjected to certain types of severe impacts that may cause significant injury to the occupants. They work together with the seat belts to help reduce the risk of death or serious injury.

SRS airbag system

■ Location of the SRS airbags

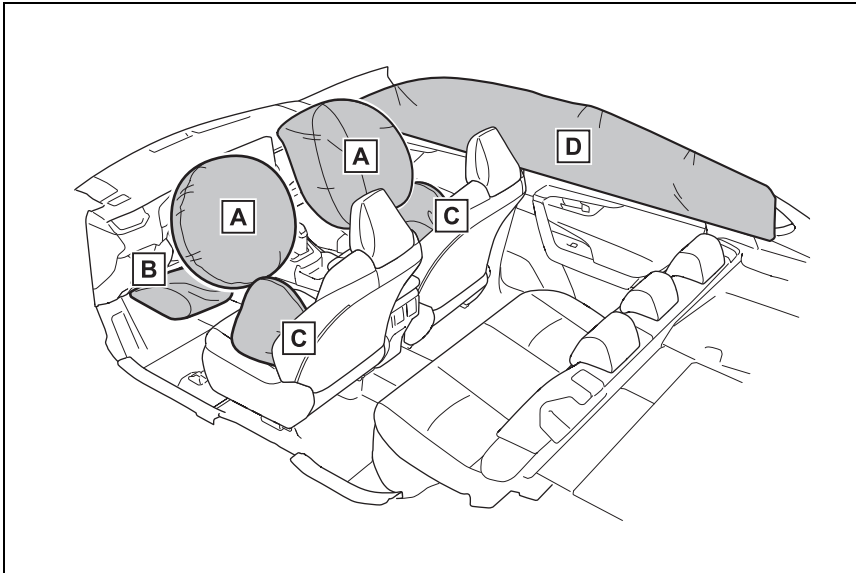

► SRS front airbags

A SRS driver airbag/front passenger airbag

Can help protect the head and chest of the driver and front passenger from impact with interior components

B SRS knee airbag

Can help provide driver protection

► SRS side and curtain shield airbags

C SRS front side airbags

Can help protect the torso of the front seat occupants

D SRS curtain shield airbags

Can help protect primarily the head of occupants in the outer seats

■ SRS airbag system components

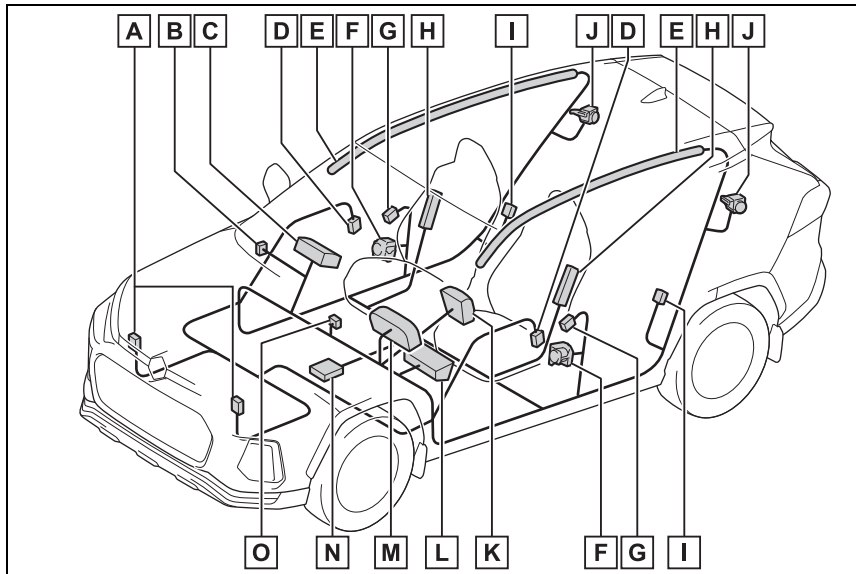

- A** Front impact sensors
- B** Airbag manual on-off switch
- C** Front passenger airbag
- D** Side impact sensors (front door)
- E** Curtain shield airbags
- F** Seat belt pretensioners and force limiters (front seats)
- G** Side impact sensors (front)
- H** Side airbags
- I** Side impact sensors (rear)
- J** Seat belt pretensioners and force limiters (outboard rear seats)
- K** Driver airbag
- L** Knee airbag
- M** SRS warning light
- N** Airbag sensor assembly
- O** "PASSENGER AIR BAG" indicator

The main SRS airbag system components are shown above. The SRS airbag system is controlled by the airbag sensor assembly. As the airbags deploy, a chemical reaction in the inflators quickly fills the airbags with non-toxic gas to help restrain the motion of the occupants.

■ If the SRS airbags deploy (inflate)

- Slight abrasions, burns, bruising etc., may be sustained from SRS airbags, due to the extremely high speed deployment (inflation) by hot gases.
- A loud noise and white powder will be emitted.
- Parts of the airbag module (steering wheel hub, airbag cover and inflator) as well as the front seats, parts of the front and rear pillars, and roof side rails, may be hot for several minutes. The airbag itself may also be hot.
- The windshield may crack.
- The hybrid system will be stopped and fuel supply to the engine will be stopped. (→P.92)
- All of the doors will be unlocked. (→P.192)
- The brakes and stop lights will be controlled automatically. (→P.393)
- The interior lights will turn on automatically. (→P.419)
- The emergency flashers will turn on automatically. (→P.500)

■ SRS airbag deployment conditions (SRS front airbags)

- The SRS front airbags will deploy in the event of an impact that exceeds the set threshold level (the level of force corresponding to an approximately 20-30 km/h [12-18 mph] frontal collision with a fixed wall that does not move or deform).

However, this threshold velocity will be considerably higher in the following situations:

- If the vehicle strikes an object, such as a parked vehicle or sign pole, which can move or deform on impact

- If the vehicle is involved in an under-ride collision, such as a collision in which the front of the vehicle under-rides, or goes under, the bed of a truck
- Depending on the type of collision, it is possible that only the seat belt pretensioners will activate.

■ SRS airbag deployment conditions (SRS side and curtain shield airbags)

- The SRS side and curtain shield airbags will deploy in the event of an impact that exceeds the set threshold level (the level of force corresponding to the impact force produced by an approximately 1500 kg [3300 lb.] vehicle colliding with the vehicle cabin from a direction perpendicular to the vehicle orientation at an approximate speed of 20 -30 km/h [12 -18 mph]).
- Both SRS curtain shield airbags may also deploy in the event of a severe frontal collision.

■ Conditions under which the SRS airbags may deploy (inflate), other than a collision

The SRS front airbags and SRS curtain shield airbags may also deploy if a serious impact occurs to the underside of your vehicle. Some examples are shown in the illustration.

- Hitting a curb, edge of pavement or hard surface
- Falling into or jumping over a deep hole
- Landing hard or falling

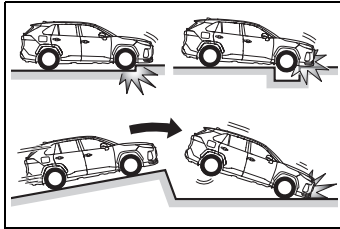

■ **Types of collisions that may not deploy the SRS airbags (SRS front airbags)**

The SRS front airbags do not generally inflate if the vehicle is involved in a side or rear collision, if it rolls over, or if it is involved in a low-speed frontal collision. But, whenever a collision of any type causes sufficient forward deceleration of the vehicle, deployment of the SRS front airbags may occur.

- Collision from the side
- Collision from the rear
- Vehicle rollover

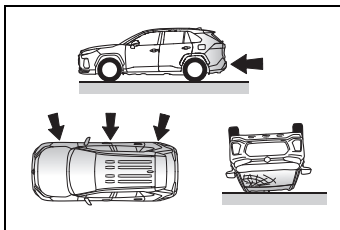

■ **Types of collisions that may not deploy the SRS airbags (SRS side and curtain shield airbags)**

The SRS side and curtain shield airbags may not activate if the vehicle is subjected to a collision from the side at certain angles, or a collision to the side of the vehicle body other than the passenger compartment.

- Collision from the side to the vehicle body other than the passenger compartment
- Collision from the side at an angle

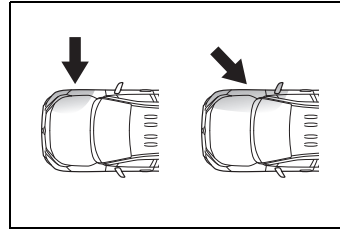

The SRS side airbags do not generally inflate if the vehicle is involved in a frontal or rear collision, if it rolls over, or if it is involved in a low-speed side collision.

- Collision from the front
- Collision from the rear
- Vehicle rollover

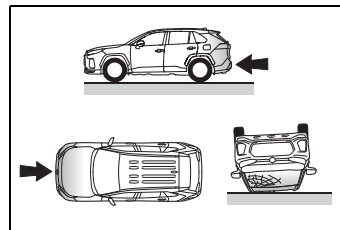

The SRS curtain shield airbags do not generally inflate if the vehicle is involved in a rear collision, if it rolls over, or if it is involved in a low-speed side or low-speed frontal collision.

- Collision from the rear
- Vehicle rollover

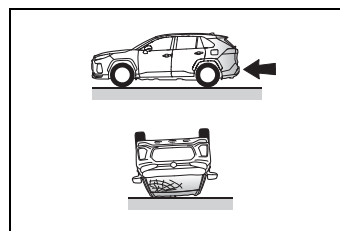

■ **When to contact a SUZUKI dealer or a qualified workshop**

In the following cases, the vehicle will require inspection and/or repair. Contact a SUZUKI dealer or a qualified workshop as soon as possible.

- Any of the SRS airbags have been

inflated.

- The front of the vehicle is damaged or deformed, or was involved in an accident that was not severe enough to cause the SRS front airbags to inflate.

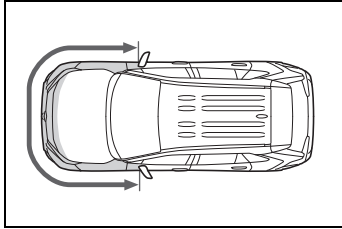

- A portion of a door or its surrounding area is damaged, deformed or has had a hole made in it, or the vehicle was involved in an accident that was not severe enough to cause the SRS side and curtain shield airbags to inflate.

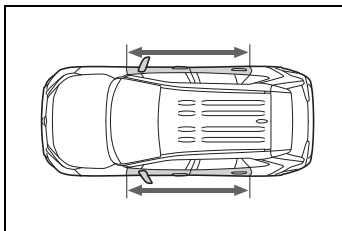

- The pad section of the steering wheel, dashboard near the front passenger airbag or lower portion of the instrument panel is scratched, cracked, or otherwise damaged.

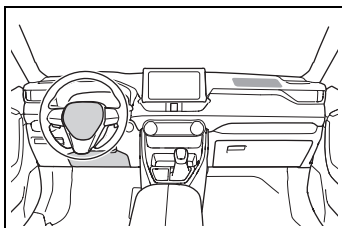

- The surface of the seats with the SRS side airbag is scratched, cracked, or otherwise damaged.

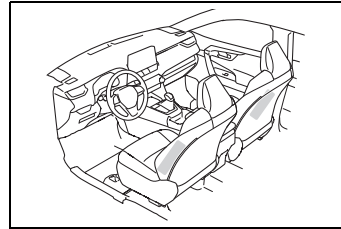

- The portion of the front pillars, rear pillars or roof side rail garnishes (padding) containing the SRS curtain shield airbags inside is scratched, cracked, or otherwise damaged.

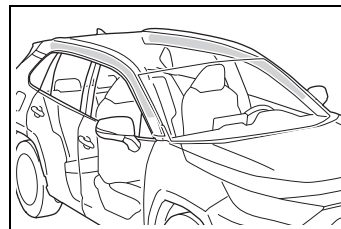

WARNING

■ **SRS airbag precautions**

Observe the following precautions regarding the SRS airbags. Failure to do so may cause death or serious injury.

- The driver and all passengers in the vehicle must wear their seat belts properly. The SRS airbags are supplemental devices to be used with the seat belts.

**WARNING**

- The SRS driver airbag deploys with considerable force, and can cause death or serious injury especially if the driver is very close to the airbag.

Since the risk zone for the driver's airbag is the first 50 - 75 mm (2 - 3 in.) of inflation, placing yourself 250 mm (10 in.) from your driver airbag provides you with a clear margin of safety. This distance is measured from the center of the steering wheel to your breastbone. If you sit less than 250 mm (10 in.) away now, you can change your driving position in several ways:

- Move your seat to the rear as far as you can while still reaching the pedals comfortably.
- Slightly recline the back of the seat. Although vehicle designs vary, many drivers can achieve the 250 mm (10 in.) distance, even with the driver seat all the way forward, simply by reclining the back of the seat somewhat. If reclining the back of your seat makes it hard to see the road, raise yourself by using a firm, non-slippery cushion, or raise the seat if your vehicle has that feature.
- If your steering wheel is adjustable, tilt it downward. This points the airbag toward your chest instead of your head and neck.

The seat should be adjusted as recommended above, while still maintaining control of the foot pedals, steering wheel, and your view of the instrument panel controls.

- The SRS front passenger airbag also deploys with considerable force, and can cause death or serious injury especially if the front passenger is very close to the airbag. The front passenger seat should be as far from the airbag as possible with the seatback adjusted, so the front passenger sits upright.
- Improperly seated and/or restrained infants and children can be killed or seriously injured by a deploying airbag. An infant or child who is too small to use a seat belt should be properly secured using a child restraint system. Suzuki strongly recommends that all infants and children be placed in the rear seats of the vehicle and properly restrained. The rear seats are safer for infants and children than the front passenger seat. (→P.48)
- Do not sit on the edge of the seat or lean against the dashboard.

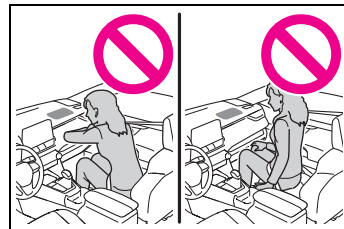

- Do not allow a child to stand in front of the SRS front passenger airbag unit or sit on the knees of a front passenger.

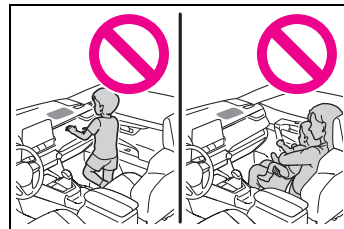

- Do not allow the front seat occupants to hold items on their knees.

WARNING

- Do not lean against the door, the roof side rail or the front, side and rear pillars.



- Do not allow anyone to kneel on the passenger seat toward the door or put their head or hands outside the vehicle.

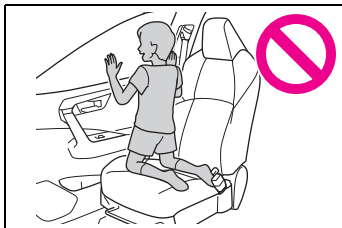

- Do not attach anything to or lean anything against areas such as the dashboard, steering wheel pad and lower portion of the instrument panel. These items can become projectiles when the SRS driver, front passenger and knee airbags deploy.

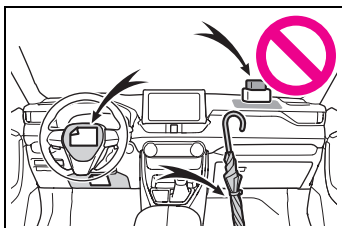

- Do not attach anything to areas such as a door, windshield, side windows, front or rear pillar, roof side rail and assist grip.

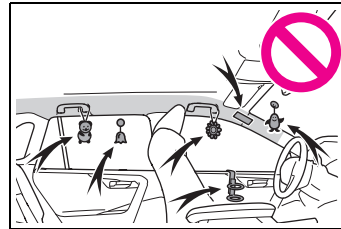

- Do not hang coat hangers or other hard objects on the coat hooks. All of these items could become projectiles and may cause death or serious injury, should the SRS curtain shield airbags deploy.
- If a vinyl cover is put on the area where the SRS knee airbag will deploy, be sure to remove it.
- Do not use seat accessories which cover the parts where the SRS side airbags inflate as they may interfere with inflation of the SRS airbags. Such accessories may prevent the SRS side airbags from activating correctly, disable the system or cause the SRS side airbags to inflate accidentally, resulting in death or serious injury.
- Do not strike or apply significant levels of force to the area of the SRS airbag components or the front doors. Doing so can cause the SRS airbags to malfunction.
- Do not touch any of the component parts immediately after the SRS airbags have deployed (inflated) as they may be hot.

**WARNING**

- If breathing becomes difficult after the SRS airbags have deployed, open a door or side window to allow fresh air in, or leave the vehicle if it is safe to do so. Wash off any residue as soon as possible to prevent skin irritation.
- If the areas where the SRS airbags are stored, such as the steering wheel pad and front and rear pillar garnishes, are damaged or cracked, have them replaced by a SUZUKI dealer or a qualified workshop.

■ Modification and disposal of SRS airbag system components

Do not dispose of your vehicle or perform any of the following modifications without consulting a SUZUKI dealer or a qualified workshop. The SRS airbags may malfunction or deploy (inflate) accidentally, causing death or serious injury.

- Installation, removal, disassembly and repair of the SRS airbags
- Repairs, modifications, removal or replacement of the steering wheel, instrument panel, dashboard, seats or seat upholstery, front, side and rear pillars, roof side rails, front door panels, front door trims or front door speakers
- Modifications to the front door panel (such as making a hole in it)
- Repairs or modifications of the front fender, front bumper, or side of the occupant compartment
- Installation of a grille guard (bull bars, kangaroo bar, etc.), snow plows or winches
- Modifications to the vehicle's suspension system

- Installation of electronic devices such as mobile two-way radios (RF-transmitter) and CD players

Exhaust gas precautions

Harmful substance to the human body is included in exhaust gases if inhaled.

 **WARNING**

Exhaust gases contain harmful carbon monoxide (CO), which is colorless and odorless. Observe the following precautions.

Failure to do so may cause exhaust gases to enter the vehicle and may lead to an accident caused by lightheadedness, or may lead to death or a serious health hazard.

■ Important points while driving

- Keep the back door closed.
- If you smell exhaust gases in the vehicle even when the back door is closed, open the side windows and have the vehicle inspected at a SUZUKI dealer or a qualified workshop as soon as possible.

■ When parking

- If the vehicle is in a poorly ventilated area or a closed area, such as a garage, stop the hybrid system.
- Do not leave the vehicle with the hybrid system operating for a long time.
If such a situation cannot be avoided, park the vehicle in an open space and ensure that exhaust fumes do not enter the vehicle interior.
- Do not leave the hybrid system operating in an area with snow build-up, or where it is snowing. If snowbanks build up around the vehicle while the hybrid system is operating, exhaust gases may collect and enter the vehicle.

■ Exhaust pipe

The exhaust system needs to be checked periodically. If there is a hole or crack caused by corrosion, damage to a joint or abnormal exhaust noise, be sure to have the vehicle inspected and repaired by a SUZUKI dealer or a qualified workshop.

Airbag manual on-off system

This system deactivates the front passenger airbag.

Only deactivate the airbag when using a child restraint system on the front passenger seat.

System components

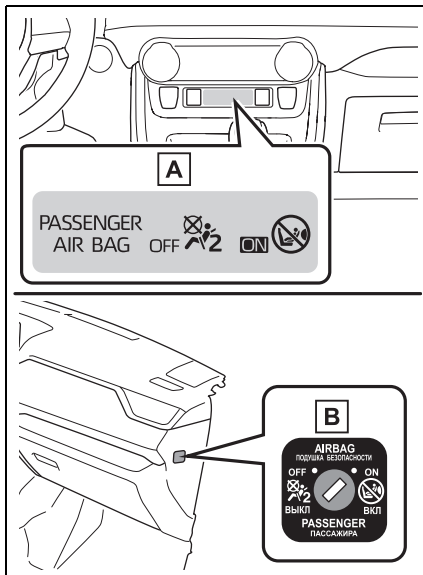

A “PASSENGER AIR BAG” indicator

“PASSENGER AIR BAG” and “ON” indicator light turn on when the airbag system is on, and about after 60 seconds they go off (only when the power switch is in ON).

B Airbag manual on-off switch

“PASSENGER AIR BAG” indicator information

If any of the following problems occur, it is possible that there is a malfunction in the system. Have the vehicle inspected by a SUZUKI dealer or a qualified workshop.

- The “OFF” indicator does not illuminate when the airbag manual on-off switch is set to “OFF”.
- The indicator light does not change when the airbag manual on-off switch is switched to “ON” or “OFF”.

Deactivating the airbags for the front passenger

Insert the mechanical key into the cylinder and turn to the “OFF” position.

The “OFF” indicator light turns on (only when the power switch is in ON).

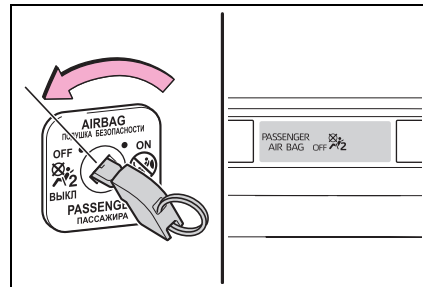

**WARNING****■ When installing a child restraint system**

For safety reasons, always install a child restraint system in a rear seat. In the event that the rear seat cannot be used, the front seat can be used as long as the airbag manual on-off system is set to "OFF".

If the airbag manual on-off system is left on, the strong impact of the airbag deployment (inflation) may cause serious injury or even death.

■ When a child restraint system is not installed on the front passenger seat

Ensure that the airbag manual on-off system is set to "ON".

If it is left off, the airbag may not deploy in the event of an accident, which may result in serious injury or even death.

Riding with children

Observe the following precautions when children are in the vehicle.

Use a child restraint system appropriate for the child, until the child becomes large enough to properly wear the vehicle's seat belt.

- It is recommended that children sit in the rear seats to avoid accidental contact with the shift lever, wiper switch, etc.
- Use the rear door child-protector lock or the window lock switch to avoid children opening the door while driving or operating the power window accidentally. (→P.194, 260)
- Do not let small children operate equipment which may catch or pinch body parts, such as the power window, hood, back door, seats, etc.

**WARNING****■ When children are in the vehicle**

Never leave children unattended in the vehicle, and never allow children to have or use the key.

Children may be able to start the vehicle or shift the vehicle into neutral.

There is also a danger that children may injure themselves by playing with the side windows or other features of the vehicle. In addition, heat build-up or extremely cold temperatures inside the vehicle can be fatal to children.

Child restraint systems

Before installing a child restraint system in the vehicle, there are precautions that need to be observed, different types of child restraint systems, as well as installation methods, etc., written in this manual.

- Use a child restraint system when riding with a small child that cannot properly use a seat belt. For the child's safety, install the child restraint system to a rear seat. Be sure to follow the installation method that is in the operation manual enclosed with the restraint system.
- The use of a Suzuki genuine child restraint system is recommended, as it is safer to use in this vehicle. Suzuki genuine child restraint systems are made specifically for Suzuki vehicles. They can be purchased at a Suzuki dealer.

Table of contents

Points to remember: P.48

When using a child restraint system: P.49

Child restraint system compatibility for each seating position: P.52

Child restraint system installation method: P.56

- Fixed with a seat belt: P.57

- Fixed with an ISOFIX lower anchorage: P.59
- Using a top tether anchorage: P.60

Points to remember

- Prioritize and observe the warnings, as well as the laws and regulations for child restraint systems.
- Use a child restraint system until the child becomes large enough to properly wear the vehicle's seat belt.
- Choose a child restraint system appropriate to the age and size of the child.
- Note that not all child restraint systems can fit in all vehicles. Before using or purchasing a child restraint system, check the compatibility of the child restraint system with seat positions. (→P.52)

WARNING

■ When a child is riding

Observe the following precautions. Failure to do so may result in death or serious injury.

- For effective protection in automobile accidents and sudden stops, a child must be properly restrained, using a seat belt or child restraint system which is correctly installed. For installation details, refer to the operation manual enclosed with the child restraint system. General installation instructions are provided in this manual.

**WARNING**

- Suzuki strongly urges the use of a proper child restraint system that conforms to the weight and size of the child, installed on the rear seat. According to accident statistics, the child is safer when properly restrained in the rear seat than in the front seat.

- Holding a child in your or someone else's arms is not a substitute for a child restraint system. In an accident, the child can be crushed against the windshield or between the holder and the interior of the vehicle.

- **Handling the child restraint system**

If the child restraint system is not properly fixed in place, the child or other passengers may be seriously injured or even killed in the event of sudden braking, sudden swerving, or an accident.

- If the vehicle were to receive a strong impact from an accident, etc., it is possible that the child restraint system has damage that is not readily visible. In such cases, do not reuse the restraint system.

- Depending on the child restraint system, installation may be difficult or impossible. In those cases, check whether the child restraint system is suitable for installment in the vehicle (→P.52). Be sure to install and observe the usage rules after carefully reading the child restraint system fixing method in this manual, as well as the operation manual enclosed with the child restraint system.

- Keep the child restraint system properly secured on the seat even if it is not in use. Do not store the child restraint system unsecured in the passenger compartment.

- If it is necessary to detach the child restraint system, remove it from the vehicle or store it securely in the luggage compartment.

When using a child restraint system

■ When installing a child restraint system to a front passenger seat

For the safety of a child, install a child restraint system to a rear seat. When installing a child restraint system to the front passenger seat is unavoidable, adjust the seat as follows and install the child restraint system:

- Adjust the seatback angle to the most upright position.

When installing a forward-facing child seat, if there is a gap between the child seat and the seatback, adjust the seatback angle until good contact is achieved.

- Move the front seat fully rearward.

- If the head restraint interferes with the child restraint system installation and the head restraint can be removed, remove the head restraint. Otherwise, put the head restraint in the uppermost position.

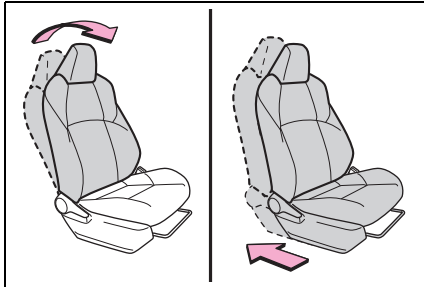

⚠ WARNING

■ When using a child restraint system

Observe the following precautions. Failure to do so may result in death or serious injury.

- Never use a rear-facing child restraint system on the front passenger seat when the airbag manual on-off switch is on. (→P.46)
The force of the rapid inflation of the front passenger airbag can cause death or serious injury to children in the event of an accident.

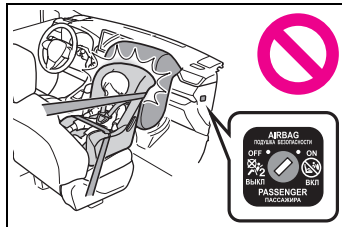

- There is a label(s) on the passenger side sun visor, indicating it is forbidden to attach a rear-facing child restraint system to the front passenger seat. Details of the label(s) are shown in the illustration below.

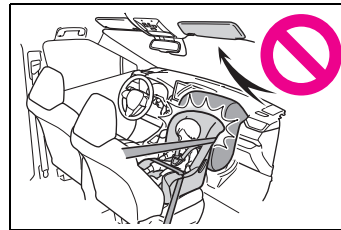

! WARNING



! WARNING

- Only put a forward-facing child restraint system on the front seat when unavoidable. When installing a forward-facing child restraint on the front passenger seat, move the seat as far back as possible. Failing to do so may result in death or serious injury if the airbags deploy (inflate).

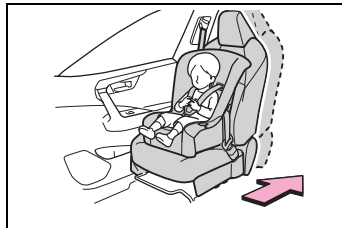

- Do not allow the child to lean his/her head or any part of his/her body against the door or the area of the seat, front or rear pillars, or roof side rails from which the SRS side airbags or SRS curtain shield airbags deploy even if the child is seated in the child restraint system. It is dangerous if the SRS side airbags and curtain shield airbags inflate, and the impact could cause death or serious injury to the child.



- When a junior seat is installed, always ensure that the shoulder belt is positioned across the center of the child's shoulder. The belt should be kept away from the child's neck, but not so that it could fall off the child's shoulder.

WARNING

- Use a child restraint system suitable to the age and size of the child and install it to the rear seat.
- If the driver's seat interferes with the child restraint system and prevents it from being attached correctly, attach the child restraint system to the right-hand rear seat (left-hand drive vehicles) or the left-hand rear seat (right-hand drive vehicles).

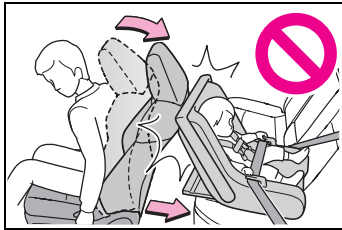

- Adjust the front passenger seat so that it does not interfere with the child restraint system.

Child restraint system compatibility for each seating position**Child restraint system compatibility for each seating position**

Compatibility of each seating position with child restraint systems (→P.53) displays the type of child restraint systems that can be used and possible seating positions for installation using symbols. Check the selected child restraint system together with the following [Before confirming the compatibility of each seating position with child restraint systems].

Before confirming the compatibility of each seating position with child restraint systems**1 Checking the child restraint system standards.**

Use a child restraint system that conforms to UN(ECE) R44^{*1} or UN(ECE) R129^{*1, 2}.

The following approval mark is displayed on child restraint systems which are conformed.

Check for an approval mark attached to the child restraint system.

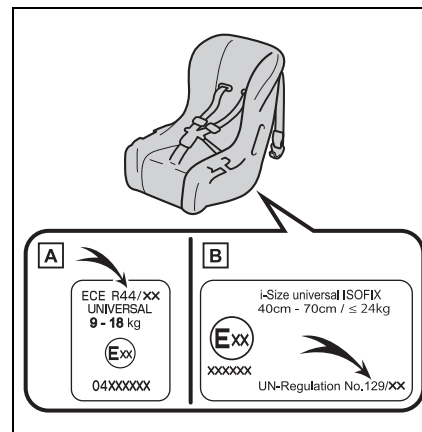

Example of the displayed regulation Number

- A** UN(ECE) R44 approval mark^{*3}
The weight range of the child who is applicable for an UN(ECE) R44 approval mark is indicated.
- B** UN(ECE) R129 approval mark^{*3}
The height range of the child who is applicable as well as available weights for an

UN(ECE) R129 approval mark is indicated.

- 2** Checking the category of the child restraint system.
Check the approval mark of the child restraint system for which of the following categories the child restraint system is suitable. Also, if there are any uncertainties, check the user's guide included with the child restraint system or contact the retailer of the child restraint system.

- “universal”
- “semi-universal”
- “restricted”
- “vehicle specific”

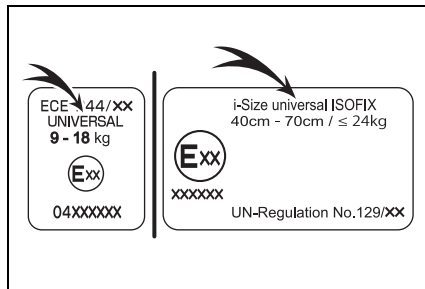

*1: UN(ECE) R44 and UN(ECE) R129 are U.N. regulations for child restraint systems.

*2: The child restraint systems mentioned in the table may not be available outside of the EU area.

*3: The displayed mark may differ depending on the product.

Compatibility of each seating position with child restraint systems

▶ Left-hand drive vehicles

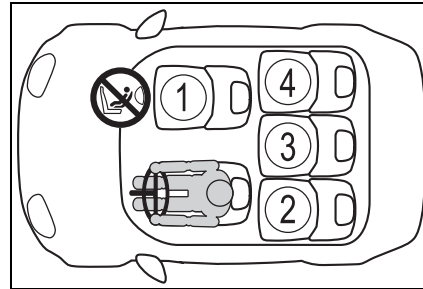

▶ Right-hand drive vehicles

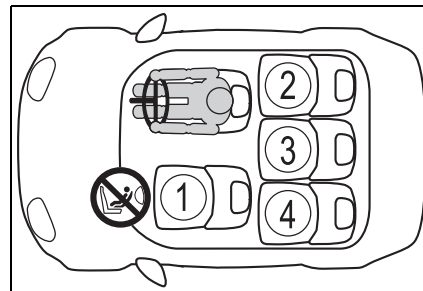

① *1, 2, 3	U ^{*4}
② *2, 3	U
③ *2, 3	U
④ *2, 3	U



Suitable for fixed with vehicle seat belt “universal” category child restraint system.



Suitable for i-Size and ISOFIX child restraint system.



Includes a top tether anchorage point.



Never use a rear-facing child restraint system on the front passenger seat when the airbag manual on-off switch is on.

*1: Move the front seat fully rearward. If the passenger seat height can be adjusted, move it to the upper most position.

*2: Adjust the seatback angle to the most upright position. When installing a forward-facing child seat, if there is a gap between the child seat and the seatback, adjust the seat-

back angle until good contact is achieved.

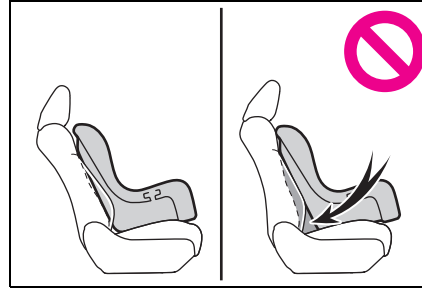

*3: If the head restraint interferes with your child restraint system, and the head restraint can be removed, remove the head restraint. Otherwise, put the head restraint in the upper most position.

*4: Use only a front-facing child restraint system when the airbag manual on-off switch is on.

■ Detail information for child restraint systems installation

Seating position					
Seat position number	①		②	③	④
	Airbag manual on-off switch				
	ON	OFF			
Seating position suitable for universal belted (Yes/No)	Yes Forward facing only	Yes	Yes	Yes	Yes
i-Size seating position (Yes/No)	No	No	Yes	No	Yes
Seating position suitable for lateral fixture (L1/L2/No)	No	No	No	No	No
Suitable rearward facing fixture (R1/R2X/R2/R3/No)	No	No	R1, R2X, R2, R3	No	R1, R2X, R2, R3

Seating position					
Seat position number	①		②	③	④
	Airbag manual on-off switch				
	ON	OFF			
Suitable forward facing fixture (F2X/F2/F3/No)	No	No	F2X, F2, F3	No	F2X, F2, F3
Suitable junior seat fixture (B2/B3/No)	No	No	B2, B3	No	B2, B3

ISOFIX child restraint systems are divided into different “fixture”. The child restraint system can be used in the seating positions for “fixture” mentioned in the table above. For kind of “fixture” relation, confirm the following table. If your child restraint system has no kind of “fixture” (or if you cannot find information in the table below), please refer to the child restraint system “vehicle list” for compatibility information or ask the retailer of your child seat.

Fixture	Description
F3	Full-height, forward-facing child restraint systems
F2	Reduced-height forward-facing child restraint systems
F2X	Reduced-height forward-facing child restraint systems
R3	Full-size, rearward-facing child restraint systems
R2	Reduced-size, rearward-facing child restraint systems
R2X	Reduced-size, rearward-facing child restraint systems
R1	Rearward-facing infant seat
L1	Left lateral-facing (carrycot) infant seat
L2	Right lateral-facing (carrycot) infant seat
B2	Junior seat
B3	Junior seat

When securing some types of child restraint systems in rear seat, it may not be possible to properly use the seat belts in positions next to the child restraint without interfering

with it or affecting seat belt effectiveness. Be sure your seat belt fits snugly across your shoulder and low on your hips. If it does not, or if it interferes with the child restraint,

move to a different position. Failure to do so may result in death or serious injury.

- When installing a child restraint in the rear seats, adjust the front seat so that it does not interfere with the child or child restraint system.
- When installing a child seat with support base, if the child seat interferes with the seatback when latching it into the support base, adjust the seatback rearward until there is no interference.
- If the seat belt shoulder anchor is ahead of the child seat belt guide, move the seat cushion forward.

forward.

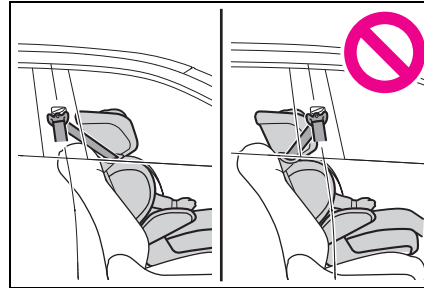

- When installing a junior seat, if the child in your child restraint system is in a very upright position, adjust the seatback angle to the most comfortable position. And if the seat belt shoulder anchor is ahead of the child seat belt guide, move the seat cushion forward.

Child restraint system installation method

Confirm with the operation manual enclosed with the child restraint system about the installation of the child restraint system.

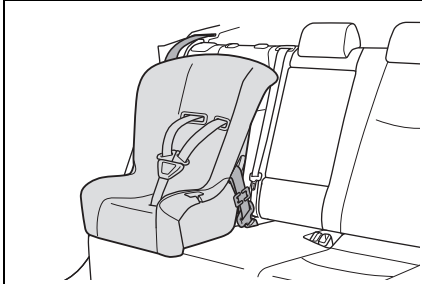
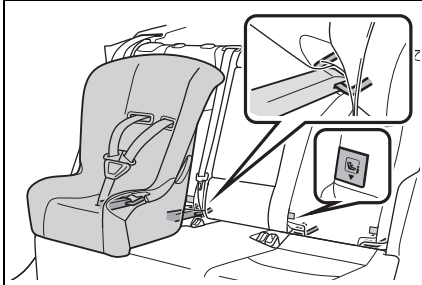
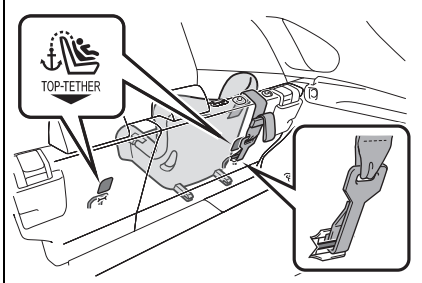
	Installation method	Page
Seat belt attachment		P.57
ISOFIX lower anchorage attachment		P.59
Top tether anchorage attachment		P.60

Child restraint system fixed with a seat belt

■ Installing child restraint system using a seat belt

Install the child restraint system in accordance to the operation manual enclosed with the child restraint system.

If the child restraint system on hand

is not within the “universal” category (or the necessary information is not in the table), refer to the “Vehicle List” provided by the child restraint system maker for various possible installation positions, or check the compatibility after asking the retailer of the child seat. (→P.52, 53)

- 1 If installing the child restraint system to the front passenger seat is unavoidable, refer to P.49 for the front passenger seat adjustment.
- 2 Adjust the seatback angle to the most upright position. When installing a forward-facing child seat, if there is a gap between the child seat and the seatback, adjust the seatback angle until good contact is achieved.
- 3 If the head restraint interferes with the child restraint system installation and the head restraint can be removed, remove the head restraint. Otherwise, put the head restraint in the upper most position. (→P.252)
- 4 Run the seat belt through the child restraint system and insert the plate into the buckle. Make sure that the belt is not twisted. Securely fix the seat belt to the child restraint system in accordance to the directions enclosed with the child restraint system.

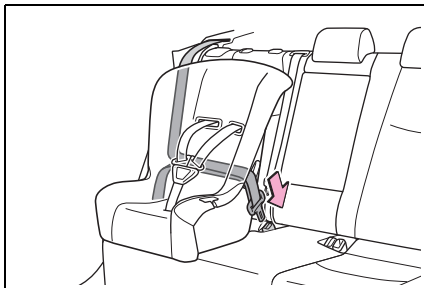

- 5 If your child restraint system is not equipped with a lock-off (a seat belt locking feature), secure the child restraint system using a locking clip.

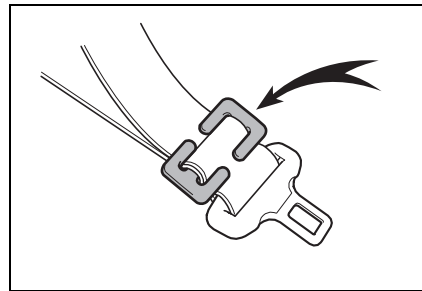

- 6 After installing the child restraint system, rock it back and forth to ensure that it is installed securely. (→P.59)

■ Removing a child restraint system installed with a seat belt

Press the buckle release button and fully retract the seat belt.

When releasing the buckle, the child restraint system may spring up due to the rebound of the seat cushion. Release the buckle while holding down the child restraint system.

Since the seat belt automatically reels itself, slowly return it to the stowing position.

■ When installing a child restraint system

You may need a locking clip to install the child restraint system. Follow the instructions provided by the manufacturer of the system. If your child restraint system does not provide a locking clip, you can purchase the following item from a SUZUKI dealer or a qualified

workshop: Locking clip for child restraint system
(Part No. T7311-92201-000)

⚠ WARNING

■ **When installing a child restraint system**

Observe the following precautions. Failure to do so may result in death or serious injury.

- Do not allow children to play with the seat belt. If the seat belt becomes twisted around a child's neck, it may lead to choking or other serious injuries that could result in death. If this occurs and the buckle cannot be unfastened, scissors should be used to cut the belt.
- Ensure that the belt and plate are securely locked and the seat belt is not twisted.
- Shake the child restraint system left and right, and forward and backward to ensure that it has been securely installed.
- After securing a child restraint system, never adjust the seat.
- When a junior seat is installed, always ensure that the shoulder belt is positioned across the center of the child's shoulder. The belt should be kept away from the child's neck, but not so that it could fall off the child's shoulder.
- Follow all installation instructions provided by the child restraint system manufacturer.

Child restraint system fixed with an ISOFIX lower anchorage

■ **ISOFIX lower anchorages (ISOFIX child restraint system)**

Lower anchorages are provided for the outboard rear seats. (Tags displaying the location of the anchorages are attached to the seats.)

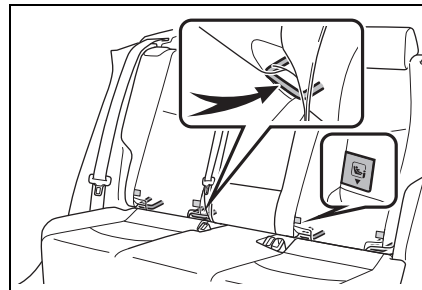

■ **Installation with ISOFIX lower anchorage (ISOFIX child restraint system)**

Install the child restraint system in accordance to the operation manual enclosed with the child restraint system.

If the child restraint system on hand is not within the "universal" category (or the necessary information is not in the table), refer to the "Vehicle List" provided by the child restraint system maker for various possible installation positions, or check the compatibility after asking the retailer of the child seat.

(→P.52, 53)

- 1 Adjust the seatback angle to the most upright position. When installing a forward-facing child

seat, if there is a gap between the child seat and the seatback, adjust the seatback angle until good contact is achieved.

- 2 If the head restraint interferes with the child restraint system installation and the head restraint can be removed, remove the head restraint. Otherwise, put the head restraint in the upper most position. (→P.252)
- 3 Check the positions of the exclusive fixing bars, and install the child restraint system to the seat.

The bars are installed in the clearance between the seat cushion and seatback.

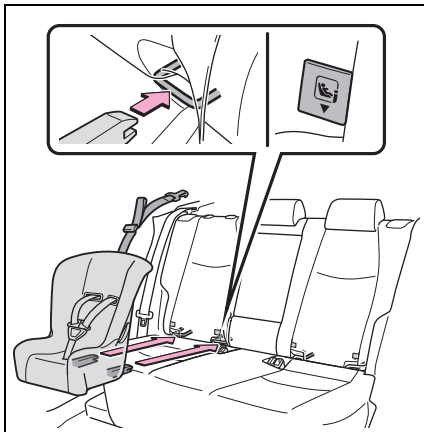

- 4 After installing the child restraint system, rock it back and forth to ensure that it is installed securely. (→P.59)

! WARNING

■ When installing a child restraint system

Observe the following precautions. Failure to do so may result in death or serious injury.

- After securing a child restraint system, never adjust the seat.
- When using the lower anchorages, be sure that there are no foreign objects around the anchorages and that the seat belt is not caught behind the child restraint system.
- Follow all installation instructions provided by the child restraint system manufacturer.

Using a top tether anchorage

■ Top tether anchorages

Top tether anchorages are provided for the outboard rear seats.

Use top tether anchorages when fixing the top strap.

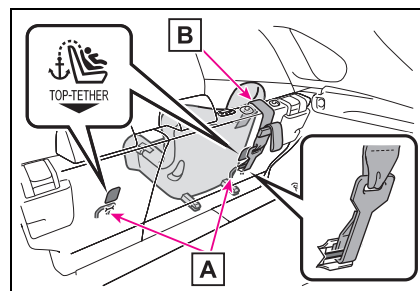

A Top tether anchorages

B Top strap

■ Fixing the top strap to the top tether anchorages

Install the child restraint system in

accordance to the operation manual enclosed with the child restraint system.

- 1 Adjust the head restraint to the upmost position.

If the head restraint interferes with the child restraint system or top strap installation and the head restraint can be removed, remove the head restraint. (→P.253)

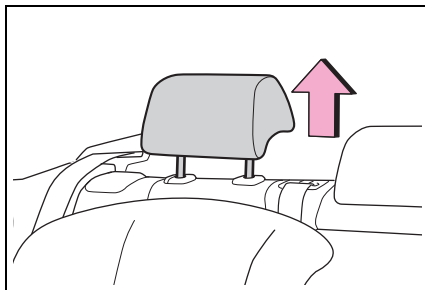

- 2 Latch the hook onto the top tether anchorage and tighten the top strap.

Make sure the top strap is securely latched. (→P.59)

When installing the child restraint system with the head restraint being raised, be sure to have the top strap pass underneath the head restraint.

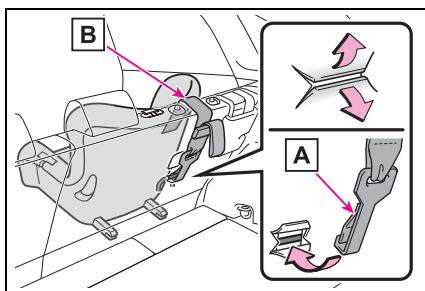

A Hook

B Top strap

WARNING

■ When installing a child restraint system

Observe the following precautions. Failure to do so may result in death or serious injury.

- Firmly attach the top strap and make sure that the belt is not twisted.
- Do not attach the top strap to anything other than the top tether anchorages.
- After securing a child restraint system, never adjust the seat.
- Follow all installation instructions provided by the child restraint system manufacturer.
- When installing the child restraint system with the head restraint being raised, after the head restraint has been raised and then the top tether anchorage has been fixed, do not lower the head restraint.

eCall*

*: Operates within the eCall coverage. The system name differs depending on the country.

eCall is a telematics service that uses Global Navigation Satellite System (GNSS) data and embedded cellular technology to enable the following emergency calls to be made: Automatic emergency calls (Automatic Collision Notification) and manual emergency calls (by pressing the “SOS” button). This service is required by European Union Regulations.

System components

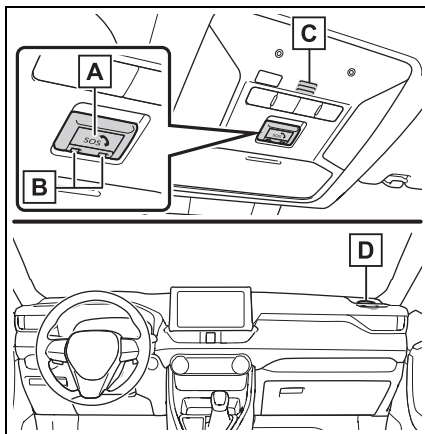

A “SOS” button*

B Indicator lights

C Microphone

D Speaker

*: This button is intended for communication with the eCall system operator. Other SOS buttons available in other systems of a motor vehicle do not relate to the device and are not intended for communication with the eCall system operator.

Emergency Notification Services

■ Automatic Emergency Calls

If any airbag deploys, the system is designed to automatically call the eCall control center.* The answering operator receives the vehicle’s location, the time of the incident and the vehicle VIN, and attempts to speak with the vehicle occupants to assess the situation. If the occupants are unable to communicate, the operator automatically treats the call as an emergency and contacts the nearest emergency services provider (112 system etc.) to describe the situation and request that assistance be sent to the location.

*: In some cases, the call cannot be made. (→P.63)

■ Manual Emergency Calls

In the event of an emergency, press the “SOS” button to call the eCall control center.* The answering operator will determine your vehicle’s location, assess the situation, and dispatch the necessary assistance required.

Make sure to open the cover before

pressing the “SOS” button.

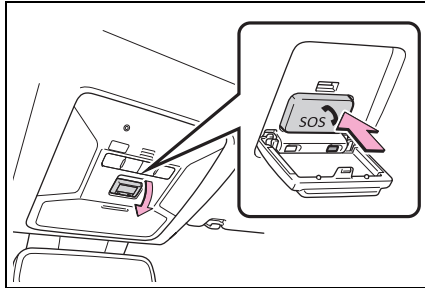

If you accidentally press the “SOS” button, tell the operator that you are not experiencing an emergency.

*: In some cases, the call cannot be made. (→P.63)

Indicator lights

When the power switch is turned to ON, the red indicator light will illuminate for 10 seconds. Then, the green indicator light will illuminate for 2 seconds and remain illuminated if the system is functioning properly.

The indicator lights indicate the following:

- If the green indicator light illuminates and stays on, the system is enabled.
- If the green indicator light flashes twice per second, an automatic or manual Emergency Call is being made.
- If the red indicator light illuminates at any time other than immediately after the power switch is turned to ON, the system may be malfunctioning or

the backup battery may be depleted.

- If the red indicator light blinks for approximately 30 seconds during an Emergency Call, the call has been disconnected or the cellular network signal is weak.

The service life of the backup battery does not exceed 3 years.

Free/Open Source Software Information

This product contains Free/Open Source Software (FOSS).

The license information and/or the source code of such FOSS can be found at the following URL.

<http://www.opensourceautomotive.com/dcm/toyota/>

⚠ WARNING

■ When the Emergency Call may not be made

- It may not be possible to make Emergency Calls in any of the following situations. In such cases, report to emergency services provider (112 system etc.) by other means such as nearby public phones.
- Even when the vehicle is in the cellular phone service area, it may be difficult to connect to the eCall control center if the reception is poor or the line is busy. In such cases, even though the system attempts to connect to the eCall control center, you may not be able to connect to the eCall control center to make Emergency Calls and contact emergency services.
- When the vehicle is out of the cellular phone service area, the Emergency Calls cannot be made.

**WARNING**

- When any related equipment (such as the “SOS” button panel, indicator lights, microphone, speaker, DCM, antenna, or any wires connecting the equipment) is malfunctioning, damaged or broken, the Emergency Call cannot be made.
- During an Emergency Call, the system makes repeated attempts to connect to the eCall control center. However, if it cannot connect to the eCall control center due to poor radio wave reception, the system may not be able to connect to the cellular network and the call may finish without connecting. The red indicator light will blink for approximately 30 seconds to indicate this disconnection.
- If the 12-volt battery’s voltage decreases or there is a disconnection, the system may not be able to connect to the eCall control center.

■ **When the Emergency Call system is replaced with a new one**

The Emergency Call system should be registered. Contact a SUZUKI dealer or a qualified workshop.

■ **For your safety**

- Please drive safely.
The function of this system is to assist you in making the Emergency Call in case of accidents such as traffic accidents or sudden medical emergencies, and it does not protect the driver or passengers in any way. Please drive safely and fasten your seatbelts at all times for your safety.
- In case of an emergency, make lives the top priority.
- If you smell anything burning or other unusual smells, leave the vehicle and evacuate to a safe area immediately.

- If the airbags deploy when the system is operating normally, the system makes emergency call. The system also makes emergency call when the vehicle is struck from the rear or rolls over, even if the airbags do not deploy.
- For safety, do not make the Emergency Call while driving.
Making calls during driving may cause mishandling of the steering wheel, which may lead to unexpected accidents.
Stop the vehicle and confirm the safety of your surroundings before making the Emergency Call.
- When changing fuses, please use the specified fuses. Using other fuses may cause ignition or smoke in the circuit and lead to a fire.
- Using the system while there is smoke or an unusual smell may cause a fire. Stop using the system immediately and consult a SUZUKI dealer or a qualified workshop.

**NOTICE**

■ **To prevent damage**

Do not pour any liquids onto the “SOS” button panel, etc. and do not impact it.

■ **If the “SOS” button panel, speaker or microphone malfunctions during an Emergency Call or manual maintenance check**

It may not be possible to make Emergency Calls, confirm the system status, or communicate with the eCall control center operator. If any of the above equipment is damaged, please consult a SUZUKI dealer or a qualified workshop.

Implementing Regulation

Implementing Regulation Annex1 PART3 User Information			Conformity
1. DESCRIPTION OF THE ECALL IN-VEHICLE SYSTEM			
1.1.	Overview of the 112-based eCall in-vehicle system, its operation and functionalities		O
1.2.	The 112-based eCall service is a public service of general interest and is accessible free of charge.		O
1.3.	The 112-based eCall in-vehicle system is activated by default. It is activated automatically by means of in-vehicle sensors in the event of a severe accident. It will also be triggered automatically when the vehicle is equipped with a TPS system which does not function in the event of a severe accident.		O
1.4.	The 112-based eCall in-vehicle system can also be triggered manually, if needed. Instructions for manual activation of the system		O
1.5.	In the event of a critical system failure that would disable the 112-based eCall in-vehicle system, the following warning will be given to the occupants of the vehicle		O

Implementing Regulation Annex1 PART3 User Information		Conformity
2. INFORMATION ON DATA PROCESSING		
2.1.	Any processing of personal data through the 112-based eCall in-vehicle system shall comply with the personal data protection rules provided for in Directives 95/46/EC and 2002/58/EC, and in particular, shall be based on the necessity to protect the vital interests of the individuals in accordance with Article 7(d) of Directive 95/46/EC.	O
2.2.	Processing of such data is strictly limited to the purpose of handling the emergency eCall to the single European emergency number 112.	O
2.3. Types of data and its recipients		
2.3.1.	The 112-based eCall in-vehicle system may collect and process only the following data: Vehicle Identification Number, Vehicle type (passenger vehicle or light commercial vehicle), Vehicle propulsion storage type (gasoline/diesel/CNG/LPG/electric/hydrogen), Vehicle last three locations and direction of travel, Log file of the automatic activation of the system and its timestamp	O
2.3.2.	Recipients of data processed by the 112-based eCall in-vehicle system are the relevant public safety answering points designated by the respective public authorities of the country on which territory they are located, to first receive and handle eCalls to the single European emergency number 112.	O

Implementing Regulation Annex1 PART3 User Information		Conformity
2.4. Arrangements for data processing		
2.4.1.	The 112-based eCall in-vehicle system is designed in such a way as to ensure that the data contained in the system memory is not available outside the system before an eCall is triggered.	O
2.4.2.	The 112-based eCall in-vehicle system is designed in such a way as to ensure that it is not traceable and not subject to any constant tracking in its normal operation status.	O
2.4.3.	The 112-based eCall in-vehicle system is designed in such a way as to ensure that data in the system internal memory is automatically and continuously removed.	O
2.4.3.1.	The vehicle location data is constantly overwritten in the internal memory of the system so as always to keep maximum of the last three up-to-date locations of the vehicle necessary for the normal functioning of the system.	O
2.4.3.2.	The log of activity data in the 112-based eCall in-vehicle system is kept for no longer than necessary for attaining the purpose of handling the emergency eCall and in any case not beyond 13 hours from the moment an emergency eCall was initiated.	O

Implementing Regulation Annex1 PART3 User Information		Conformity
2.5. Modalities for exercising data subject's rights		
2.5.1.	The data subject (the vehicle's owner) has a right of access to data and as appropriate to request the rectification, erasure or blocking of data, concerning him or her, the processing of which does not comply with the provisions of Directive 95/46/EC. Any third parties to whom the data have been disclosed have to be notified of such rectification, erasure or blocking carried out in compliance with this Directive, unless it proves impossible or involves a disproportionate effort.	O
2.5.2.	The data subject has a right to complain to the competent data protection authority if he or she considers that his or her rights have been infringed as a result of the processing of his or her personal data.	O
2.5.3.	Contact service responsible for handling access requests (if any): →P.69	O

Implementing Regulation Annex1 PART3 User Information		Conformity
3. INFORMATION ON THIRD PARTY SERVICES AND OTHER ADDED VALUE SERVICES (IF FITTED)		
3.1.	Description of the operation and the functionalities of the TPS system/added value service	N/A
3.2.	Any processing of personal data through the TPS system/other added value service shall comply with the personal data protection rules provided for in Directives 95/46/EC and 2002/58/EC.	N/A
3.2.1.	Legal basis for the use of TPS system and/or added value services and for processing data through them	N/A
3.3.	The TPS system and/or other added value services shall process personal data only on the base of the explicit consent of the data subject (the vehicle's owner or owners).	N/A
3.4.	Modalities for data processing through TPS system and/or other added value services, including any necessary additional information regarding traceability, tracking and processing of personal data	N/A
3.5.	The owner of a vehicle equipped with a TPS eCall system and/or other added value service in addition to the 112-based eCall in-vehicle system has the right to choose to use the 112-based eCall in-vehicle system rather than the TPS eCall system and the other added value service.	N/A
3.5.1.	Contact details for handling TPS eCall system deactivation requests	N/A

■ **Service responsible for handling access requests**

Refer to "Contact information". (→P.590)

70 1-3. Emergency assistance

■ Certification for eCall

Manufacturer : Continental Automotive Singapore Pte Ltd
Address : 80 Boon Keng Road, Continental Building Singapore 339780
Model : 19EU NCBOX / 19EU CBOX

Operation frequency (MHz) :

GSM 900 : Tx: 880 – 915 Rx: 925.0 – 960.0

GSM 1800 : Tx: 1710.2 – 1784.8 Rx: 1805.2 – 1879.8

WCDMA Band 1 : Tx: 1920 – 1980 Rx: 2110 – 2170

WCDMA Band 8 : Tx: 880 – 915 Rx: 925 – 960

LTE 1: Tx: 1920 – 1980 Rx: 2110 – 2170

LTE 3: Tx: 1710 – 1785 Rx: 1805 – 1880

LTE 7: Tx: 2500 – 2570 Rx: 2620 – 2690

LTE 8: Tx: 880 – 915 Rx: 925 – 960

LTE 20 : Tx: 832 – 862 Rx: 791 – 821

LTE 26: Tx: 814 – 849 Rx: 859 – 894

GNSS Receiver Frequency: 1559 – 1610

Maximum output power :

GSM 900 2W

GSM 1800 1W

WCDMA Band 1 : 0.25W

WCDMA Band 8 : 0.25W

LTE Band 1, 3, 7, 8, 20, 26 : 0.2W



The latest "DECLARATION of CONFORMITY" (DoC)
is available at the following address:
<https://www.continental-homologation.com/>

Hereby, Continental Automotive Singapore declares that the radio
equipment type is in compliance with Directive 2014/53/EU.

Immobilizer system

The vehicle's keys have built-in transponder chips that prevent the hybrid system from starting if a key has not been previously registered in the vehicle's on-board computer.

Never leave the keys inside the vehicle when you leave the vehicle.

This system is designed to help prevent vehicle theft but does not guarantee absolute security against all vehicle thefts.

Operating the system

The indicator light flashes after the power switch has been turned to OFF to indicate that the system is operating.

The indicator light goes off after the power switch has been turned to ACC or ON to indicate that the system has been canceled.

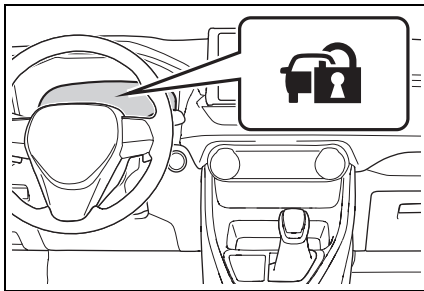

System maintenance

The vehicle has a maintenance-free type immobilizer system.

Conditions that may cause the system to malfunction

- If the grip portion of the key is in contact with a metallic object
- If the key is in close proximity to or touching a key to the security system (key with a built-in transponder chip) of another vehicle

Certification for the immobilizer system

→P.211



NOTICE

To ensure the system operates correctly

Do not modify or remove the system. If modified or removed, the proper operation of the system cannot be guaranteed.

Double locking system

Unauthorized access to the vehicle is prevented by disabling the door unlocking function from both the interior and exterior of the vehicle.

Vehicles employing this system have labels on the front side windows.

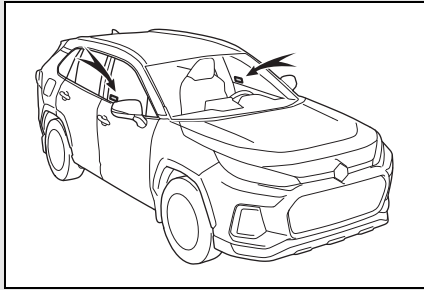

Setting/canceling the double locking system

■ Setting

Turn the power switch to OFF, have all the passengers exit the vehicle and ensure that all the doors are closed.

Using the entry function:

Touch the sensor area on the front outside door handle twice within 5 seconds.

Using the wireless remote control:

Press  twice within 5 seconds.

■ Canceling

Using the entry function:

Hold the front outside door handle.

Using the wireless remote control:

Press  .

WARNING

■ Double locking system precaution

Never activate the double locking system when there are people in the vehicle because all the doors cannot be opened from inside the vehicle.

Alarm

The alarm uses light and sound to give an alert when an intrusion is detected.

The alarm is triggered in the following situations when the alarm is set:

- A locked door is unlocked or opened in any way other than using the entry function or wireless remote control. (The doors will lock again automatically.)
- The hood is opened.
- The intrusion sensor detects something moving inside the vehicle. (Example: an intruder breaks a window and gets into the vehicle.)
- The tilt sensor detects a change of vehicle inclination.

Setting/canceling/stopping the alarm system

■ Items to check before locking the vehicle

To prevent unexpected triggering of the alarm and vehicle theft, make sure of the following:

- Nobody is in the vehicle.
- The side windows are closed before the alarm is set.
- No valuables or other personal items are left in the vehicle.

■ Setting

Close the doors and hood, and lock all the doors using the entry function or wireless remote control. The system will be set automatically after 30 seconds.

The indicator light changes from being on to flashing when the system is set.

If all doors are closed with hood open, alarm system can be set. (→P.73)

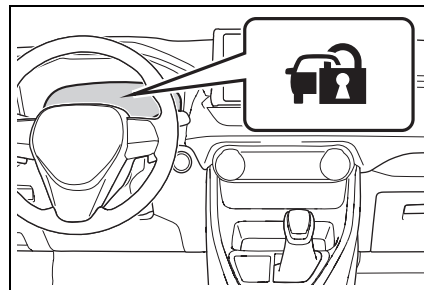

■ Canceling or stopping

Do one of the following to deactivate or stop the alarm:

- Unlock the doors using the entry function or wireless remote control.
- Start the hybrid system. (The alarm will be deactivated or stopped after a few seconds.)

■ System maintenance

The vehicle has a maintenance-free type alarm system.

■ Triggering of the alarm

The alarm may be triggered in the following situations: (Stopping the alarm deactivates the alarm system.)

- The doors are unlocked using the mechanical key.

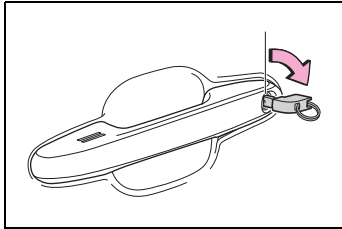

- A person inside the vehicle opens a door or hood, or unlocks the vehicle using an inside lock button.

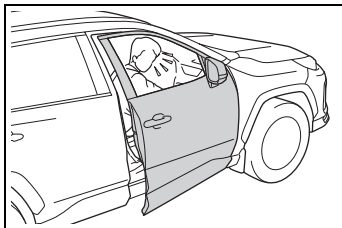

- The 12-volt battery is recharged or replaced when the vehicle is locked. (→P.535)

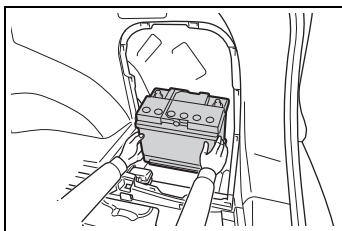

■ Alarm-operated door lock

In the following cases, depending on the situation, the door may automatically lock to prevent improper entry into the vehicle:

- When a person remaining in the vehicle unlocks the door and the alarm is activated.
- While the alarm is activated, a person remaining in the vehicle unlocks the door.
- When recharging or replacing the 12-volt battery.

■ Customization

The alarm can be set to deactivate when the mechanical key is used to unlock.

(Customizable features: →P.556)

⚠ NOTICE

■ To ensure the system operates correctly

Do not modify or remove the system. If modified or removed, the proper operation of the system cannot be guaranteed.

Intrusion sensor and tilt sensor

■ The intrusion sensor and tilt sensor detection

- The intrusion sensor detects intruders or movement in the vehicle.
- The tilt sensor detects changes in vehicle inclination, such as when the vehicle is towed away.

This system is designed to deter and prevent vehicle theft but does not guarantee absolute security against all intrusions.

■ Setting the intrusion sensor and tilt sensor

The intrusion sensor and tilt sensor will be set automatically when the alarm is set. (→P.73)

■ Canceling the intrusion sensor and tilt sensor

If you are leaving pets or other moving things inside the vehicle, make sure to disable the intrusion sensor and tilt sensor before setting the alarm, as they will respond to movement inside the vehicle.

- 1 Turn the power switch to OFF.
- 2 Press the intrusion sensor and tilt sensor cancel switch.

Press the switch again to re-enable the intrusion sensor and tilt sensor.

Each time the intrusion sensor and tilt sensor are canceled/set, a message will be shown on the multi-information display.

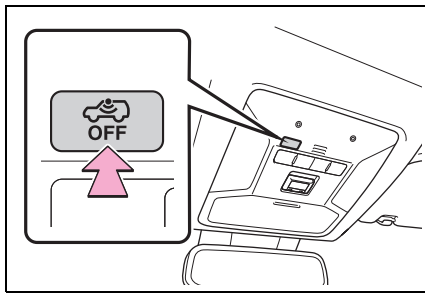

■ Canceling and automatic re-enabling of the intrusion sensor and tilt sensor

- The alarm will still be set even when the intrusion sensor and tilt sensor are canceled.
- After the intrusion sensor and tilt sensor are canceled, pressing the power switch or unlocking the doors using the entry function or wireless remote control will re-enable the intrusion sensor and tilt sensor.
- The intrusion sensor and tilt sensor will automatically be re-enabled when the alarm system is reactivated.

■ Intrusion sensor detection considerations

The sensor may trigger the alarm in the following situations:

- People or pets are in the vehicle.

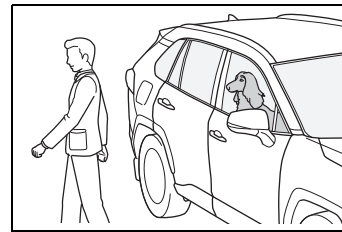

- A side window is open.

In this case, the sensor may detect the following:

- Wind or the movement of objects such as leaves and insects inside the vehicle
- Ultrasonic waves emitted from devices such as the intrusion sensors of other vehicles
- The movement of people outside the vehicle

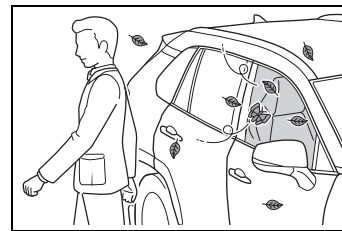

- Unstable items, such as dangling accessories or clothes hanging on the coat hooks, are in the vehicle.

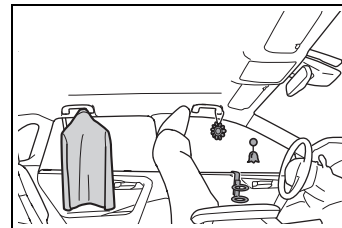

- The vehicle is parked in a place where extreme vibrations or noises occur, such as in a parking garage.

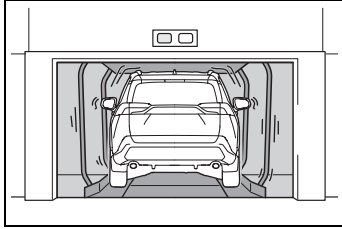

- Ice or snow is removed from the vehicle, causing the vehicle to receive repeated impacts or vibrations.

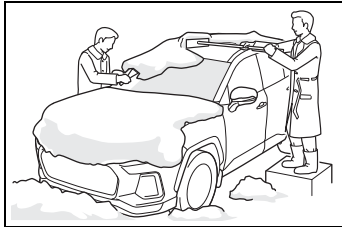

- The vehicle is inside an automatic or high-pressure car wash.
- The vehicle experiences impacts, such as hail, lightning strikes, and other kinds of repeated impacts or vibrations.

■ Tilt sensor detection considerations

The sensor may trigger the alarm in the following situations:

- The vehicle is transported by a ferry, trailer, train, etc.
- The vehicle is parked in a parking garage.
- The vehicle is inside a car wash that moves the vehicle.
- Any of the tires loses air pressure.
- The vehicle is jacked up.
- An earthquake occurs or the road caves in.

⚠ NOTICE

■ To ensure the intrusion sensor functions correctly

- To ensure that the sensors operate properly, do not touch or cover them.



- Do not spray air fresheners or other products directly into the sensor holes.

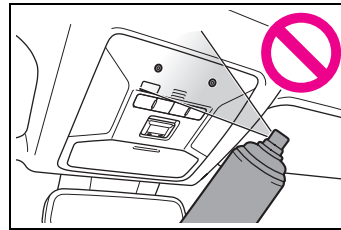

- Installing accessories other than genuine Suzuki parts or leaving objects between the driver's seat and front passenger's seat may reduce the detection performance.
- The intrusion sensor may be canceled when the electronic key is near the vehicle.

Plug-in hybrid system

2

2-1. Plug-in hybrid system

- Plug-in hybrid system features **78**
- Plug-in hybrid system precautions **88**
- Plug-in hybrid vehicle driving tips **93**
- EV driving range **96**

2-2. Charging

- Charging equipment **99**
- AC charging cable **102**
- Locking and unlocking the charging port lid and charging connector **114**
- Power sources that can be used **117**
- Charging methods **120**
- Charging tips **123**
- Things to know before charging **125**
- How to charge **128**
- Using the charging schedule function **136**
- Using the “My Room Mode” **145**
- When charging cannot be carried out **148**

Plug-in hybrid system features

The plug-in hybrid system is a system excellent in both economical efficiency of electric vehicles and practicality of hybrid vehicles.

- EV driving can be performed using electricity charged from an external power source.*
- If the amount of electricity remaining in the hybrid battery (traction battery) becomes low, the vehicle is automatically controlled in such a way that it can be driven as a hybrid vehicle through the joint use of the gasoline engine.

*: The EV driving range will vary in accordance with conditions such as vehicle speed, the amount of charge remaining in the hybrid battery (traction battery) and the usage of the air conditioning system. The gasoline engine may also be used simultaneously in accordance with driving conditions.

System components

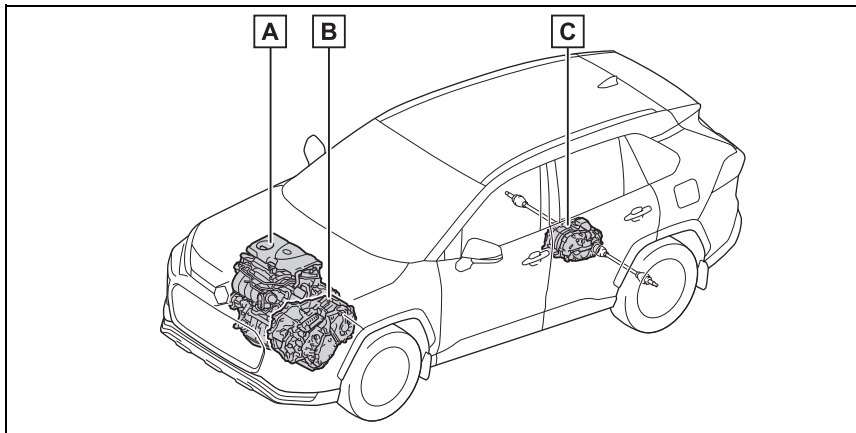

The illustration is an example for explanation and may differ from the actual item.

- A** Gasoline engine
- B** Front electric motor (traction motor)
- C** Rear electric motor (traction motor)

Plug-in hybrid system operation mode

The plug-in hybrid system operates in the following modes.

The multi-information display can be used to check which mode the plug-in hybrid system is currently being driven in. (→P.160)

■ EV mode

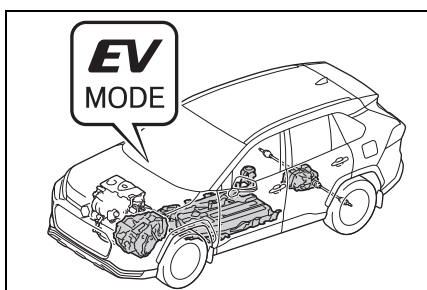

When a sufficient amount of electricity is remaining after charging^{*1}, EV driving is performed using electricity stored in the hybrid battery (traction battery).^{*2}

When in EV mode, the EV drive mode indicator illuminates.

^{*1}: The amount of remaining charge can be checked on the SOC (State of Charge) gauge. (→P.166)

^{*2}: Depending on the situation, EV driving may be canceled and both gasoline engine and electric motor are used. (→P.84)

■ AUTO EV/HV mode

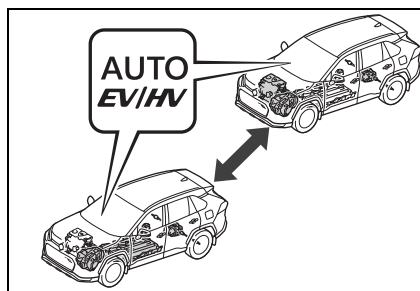

Normally, the electricity stored in the hybrid battery (traction battery) is used for EV driving. However, when more power is required, such as for driving uphill or accelerating suddenly, the gasoline engine starts and provides powerful acceleration by strongly depressing the accelerator pedal.

When the vehicle is in a condition where EV driving is possible, EV mode and AUTO EV/HV mode can be switched by operating the switch. (→P.80)

When in AUTO EV/HV mode, the AUTO EV/HV mode indicator illuminates.

■ HV mode

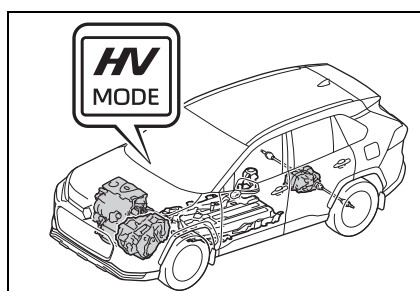

When in HV mode, the vehicle is driven using both the gasoline

- engine and electric motor. (→P.83)
- If electricity needed for EV driving in EV mode or AUTO EV/HV mode is not remaining, the operation mode will be automatically switched to HV mode.
 - The operation mode can be switched to HV mode at any timing by operating the switch to keep electricity for EV driving etc. * (→P.80). Switching to HV mode when driving on a highway or when driving uphill is recommended in order to conserve battery power.

When in HV mode, the HV drive mode indicator illuminates.

*: The EV driving range may reduce even after switching to HV mode.

■ Hybrid battery (traction battery) charge mode (→P.81)

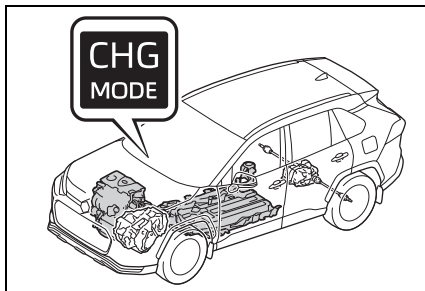

Electricity generated in the gasoline engine can be charged in the hybrid battery (traction battery) by switching to the hybrid battery (traction battery) charge mode when electricity needed for EV driving is not remaining.*

- The system may not be able to switch to the hybrid battery (traction battery) charge mode due to the state of the plug-in hybrid system. (→P.82)
- Charging time differs depending on the driving state of the vehicle when driving in hybrid battery (traction battery) charge mode.

When in the hybrid battery (traction battery) charge mode, the hybrid battery charge mode indicator illuminates.

*: When in the hybrid battery (traction battery) charge mode, the hybrid battery can be charged while driving. However, the gasoline engine runs to charge the battery and fuel consumption becomes higher compared with driving in HV mode.

Switching the plug-in hybrid system operation modes

The plug-in hybrid system operation modes can be switched using the switches.

■ Switching the plug-in hybrid system operation modes

Press the AUTO EV/HV mode switch or EV/HV mode selection switch to change modes as the following table shows.

When in EV mode, the EV drive mode indicator illuminates.

When in AUTO EV/HV mode, the AUTO EV/HV mode indicator illuminates.

When in HV mode, the HV drive mode indicator illuminates.

▶ AUTO EV/HV mode switch

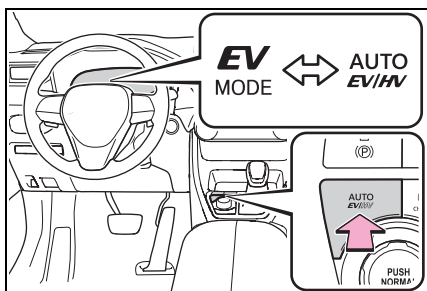

Current mode	Mode after switching
EV mode	AUTO EV/HV mode
AUTO EV/HV mode	EV mode
HV mode	AUTO EV/HV mode*

*: If there is not enough charge remaining in the hybrid battery (traction battery) to allow EV driving, AUTO EV/HV mode will not be selectable.

▶ EV/HV mode selection switch

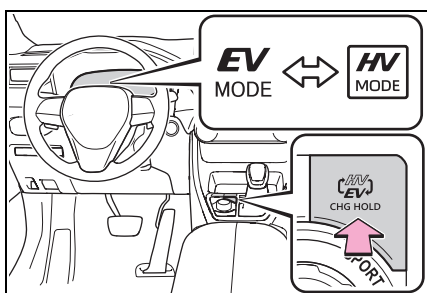

Current mode	Mode after switching
EV mode	HV mode
AUTO EV/HV mode	HV mode
HV mode	EV mode*

*: If there is not enough charge remaining in the hybrid battery (traction battery) to allow EV driving, EV mode will not be selectable.

■ Switching to the hybrid battery (traction battery) charge mode

Press and hold the EV/HV mode selection switch.

Take your hand off the switch once the hybrid battery charge mode indicator starts to blink.

The hybrid battery charge mode indicator illuminates when the switch to hybrid battery (traction battery) charge mode is complete.

When the hybrid battery (traction battery) is fully charged*, the hybrid battery (traction battery) charge mode is automatically canceled and the operation mode will be switched to HV mode.

The hybrid battery (traction battery) charge mode cannot be selected if the hybrid battery (traction battery) is almost completely charged.

*: The maximum charge amount in the hybrid battery (traction battery) charge mode is approximately 80% of the fully charged capacity for the charging from an external power source.

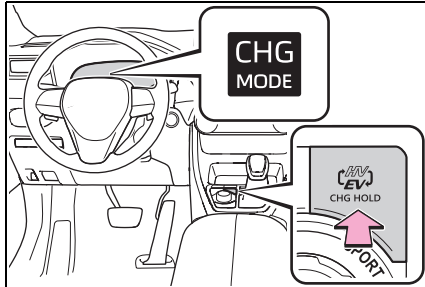

■ If the plug-in hybrid system operation mode cannot be changed

In the following situations, the plug-in hybrid system operation mode cannot be changed even if the AUTO EV/HV mode switch or EV/HV mode selection switch is pressed. (In this case, the warning message is displayed on the multi-information display when the switch is pressed.)

- When electricity needed for EV driving is not remaining (when in EV mode or AUTO EV/HV mode)
- When the traction battery is almost completely charged (hybrid battery [traction battery] charge mode)

■ When switching from EV mode to another mode using the switch

- After switching from EV mode to HV mode or hybrid battery (traction battery) charge mode and the power switch is turned off, the system returns to EV mode the next time the vehicle is started.*
- After switching from EV mode to AUTO EV/HV mode and the power switch is turned off, the system does not return to EV mode the next time the vehicle is started.*

*: If there is not enough charge remaining in the hybrid battery (traction battery) to allow EV driving, the system switches to HV mode.

■ Hybrid battery (traction battery) charge mode

- The following may occur to protect the system, etc.
 - Cannot switch to hybrid battery (traction battery) charge mode or cannot cancel it
 - Gasoline engine does not start or stops even after switching to hybrid battery (traction battery) charge mode
- If a load to the system is large, such as when the power consumption of the air conditioning system is large or when the temperature of the engine coolant is high, it may take longer time than usual to charge using the hybrid battery (traction battery) charge mode, or charging to the hybrid battery (traction battery) may not be performed.



WARNING

■ When using the hybrid battery (traction battery) charge mode

Observe the following precautions when using the hybrid battery (traction battery) charge mode while parking.

Failure to do so may lead to death or serious health hazard, as the gasoline engine operates when in the hybrid battery (traction battery) charge mode.

- Do not stop the vehicle near flammable materials.
- Do not use the hybrid battery (traction battery) charge mode in a closed area where ventilation is insufficient, such as in a garage or area with snow buildup.

Control when driving in each mode

■ When in EV mode

In EV mode, EV driving (driving

using only the electric motor)* is possible. However, depending on the situation, EV driving may be canceled and both gasoline engine and electric motor are used (→P.84). Also, if a little electricity is remaining in the hybrid battery (traction battery), HV mode is automatically selected. To drive in EV mode long, observe the followings.

- Avoid sudden acceleration and sudden deceleration, and be sure to drive smoothly. If you repeatedly accelerate, the hybrid battery (traction battery) charge will deplete quickly. Also, EV driving may be canceled by rapid acceleration or vehicle speed.
- Restrain your speed as much as possible. The distance that can be driven in EV mode will reduce considerably at high speeds.

*: The EV driving range can be checked using the multi-information display. (→P.173)

■ When in AUTO EV/HV mode

Only the electric motor is used for EV driving* during normal driving, but when the accelerator pedal is strongly depressed, the gasoline engine starts. (→P.84)

Also, when the hybrid battery (traction battery) level is low, the mode switches to HV mode automatically the same as in EV mode.

AUTO EV/HV mode is suitable for

driving conditions when more power is required, such as for driving uphill or accelerating suddenly. However, because the gasoline engine will start more easily, it is recommended to drive in EV mode usually.

*: The EV driving range can be checked using the multi-information display. (→P.173)

■ When in HV mode

The vehicle can be used in the same way as a standard hybrid vehicle.

In HV mode, controls are primarily carried out as follows in accordance with the driving conditions.

- The gasoline engine stops* when the vehicle is stopped.
- During start off, the electric motor (traction motor) drives the vehicle.
- During normal driving, the gasoline engine and electric motor (traction motor) are controlled effectively, and the vehicle is driven with optimum fuel efficiency. Also, when necessary, the electric motor (traction motor) operates as an electrical generator to charge the hybrid battery (traction battery).
- When the accelerator pedal is depressed heavily, drive force from both the gasoline engine and the electric motor (traction motor) is used to accelerate.

*: When the hybrid battery (traction battery) requires charging or the engine is warming up, etc., the gasoline engine will not automatically stop. (→P.85)

■ **When braking (regenerative braking)**

The electric motor (traction motor) charges the hybrid battery (traction battery).

The EV driving range can be extended by actively using this regenerative braking to store electricity in the hybrid battery (traction battery).

Moreover, as fuel consumption is also reduced when in HV mode, the regenerative braking system can be used effectively.

■ **Regenerative braking**

In the following situations, kinetic energy is converted to electric energy and deceleration force can be obtained in conjunction with the recharging of the hybrid battery (traction battery).

- The accelerator pedal is released while driving with the shift lever in D or S.
- The brake pedal is depressed while driving with the shift lever in D or S.

■ **EV driving range**

- The EV driving range is displayed on the multi-information display. (→P.173)
- The EV driving range changes in accordance with the charge status of the hybrid battery (traction battery), the speed of the vehicle, etc.
- Even if there is enough charge remaining in the hybrid battery (traction battery), EV driving may be canceled

and both gasoline engine and electric motor are used depending on the situation. (→P.84)

■ **EV indicator**

The EV indicator comes on when the vehicle is driven using only the electric motor (traction motor) or the gasoline engine is stopped.

The on/off operation of the EV indicator can be changed. (→P.177)

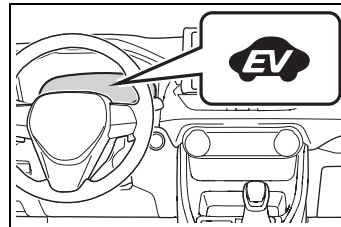

■ **After EV mode has switched to HV mode due to low hybrid battery (traction battery) charge**

If the hybrid battery (traction battery) is regenerated by driving continuously down a long slope, the EV driving range etc. will be displayed on the multi-information display and EV mode will be automatically switched to.

If EV mode is not switched to even though EV driving range is being displayed, EV mode can be switched to by pressing the EV/HV mode selection switch.

■ **Gasoline engine operation in EV mode or AUTO EV/HV mode**

Even if there is a sufficient amount of electricity remaining in the hybrid battery (traction battery) and EV driving range (→P.173) is being displayed on the multi-information display, EV driving (driving using only the electric motor) may be canceled and both gasoline engine and electric motor are used depending on the situation (EV driving will be returned to automatically after EV driving becomes possible again).

EV driving may be canceled automatically in the following circumstances*1:

- When vehicle speed is more than approximately 135 km/h (84 mph).
- When power is needed temporarily, for example when the accelerator pedal is depressed firmly or when accelerating suddenly.*²
- When the temperature of the hybrid system is high.
The vehicle has been left in the sun, driven on a hill, driven at high speeds, etc.
- When the temperature of the hybrid system is low.
- When the heater is switched on when the outside temperature is below about -10°C (14°F).
- When the windshield defogger switch is pressed. (→P.407)
- When the system determines that the gasoline engine needs to be started.

*¹: The gasoline engine may also operate in circumstances other than those listed above, depending on conditions.

*²: When driving in AUTO EV/HV mode. Even in EV mode, the gasoline engine may start, depending on the condition of the hybrid battery (traction battery).

■ If “Engine Started to Protect System EV driving unavailable” is displayed on the multi-information display

EV driving may be canceled in order to protect the hybrid system, etc. In this case, perform driving with the gasoline engine until EV driving will be returned to automatically.

■ Conditions in which the gasoline engine may not stop

The gasoline engine starts and stops automatically. However, it may not stop automatically in the following conditions*:

- During gasoline engine warm-up

- During hybrid battery (traction battery) charging
- When the temperature of the hybrid battery (traction battery) is high or low
- When the windshield defogger switch is pressed. (→P.407)

*: Depending on the circumstances, the gasoline engine may also not stop automatically in situations other than those above.

■ Sounds and vibrations specific to a hybrid vehicle

There may be no engine sound or vibration even though the vehicle is able to move with the “READY” indicator is illuminated. For safety, apply the parking brake and make sure to shift the shift lever to P when parked.

The following sounds or vibrations may occur when the hybrid system is operating and are not a malfunction.

- Motor sounds may be heard from the engine compartment.
- Sounds may be heard from the hybrid battery (traction battery) when the hybrid system starts or stops.
- Relay operating sounds such as a snap or soft clank will be emitted from the hybrid battery (traction battery), behind the rear seats, when the hybrid system is started or stopped.
- Sounds from the hybrid system may be heard when the back door is open.
- Sounds may be heard from the transmission when the gasoline engine starts or stops, when driving at low speeds, or during idling.
- Engine sounds may be heard when accelerating sharply.
- Sounds may be heard due to regenerative braking when the brake pedal is depressed or as the accelerator pedal is released.
- Vibration may be felt when the gasoline engine starts or stops.
- Cooling fan sounds may be heard

from the air intake vent under the rear seat. (→P.92)

- Sounds may be heard from near the hybrid battery (traction battery) in accordance with the operation of the air conditioning system or “Battery Cooler” (→P.121).

■ Maintenance, repair, recycling, and disposal

Contact a SUZUKI dealer or a qualified workshop regarding maintenance, repair, recycling and disposal. Do not dispose of the vehicle yourself.

Charging (→P.99)

In order to make EV mode or AUTO EV/HV mode available, charge the hybrid battery (traction battery) from an external power source before using the vehicle.

Even if charging the hybrid battery (traction battery) has not been completed, the vehicle can be driven. However, if there is not enough charge remaining, it is possible that the vehicle cannot be driven in EV mode or AUTO EV/HV mode, or the EV driving range will become shorter.

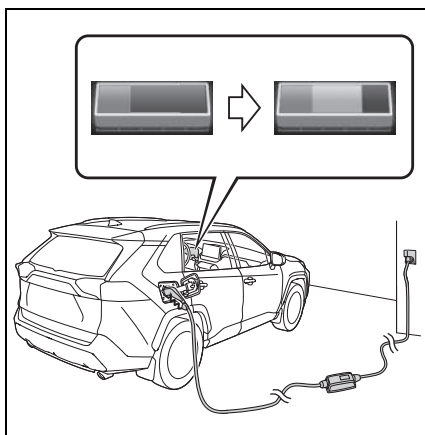

■ Refilling fuel

Plug-in hybrid vehicles can be driven using electricity charged from an external power source. However, as the gasoline engine is used depending on the situation (→P.84) even if in EV mode or AUTO EV/HV mode, and the gasoline engine is provided on board as a power source for driving in HV mode, it is needed to refueling the vehicle.

Check the fuel amount and refill immediately when the fuel level becomes low. (→P.304)

■ If the vehicle is not used for a long time

- The 12-volt battery may discharge. In this event, charge the 12-volt battery. (→P.535)

In order to prevent the hybrid battery (traction battery) from becoming extremely low in charge, charge the hybrid battery (traction battery) from external power source or start the hybrid system at least once every 2 or 3 months, and turn the power switch off after the gasoline engine has stopped automatically. (If the gasoline engine does not start up even after approximately 10 seconds have passed since the “READY” indicator came on, the power switch can be turned to off without any further action.)

When the 12-volt battery is discharged, refer to “If the 12-volt battery is discharged” (→P.535) and perform the correction procedure.

- When the vehicle is left with the AC charging cable connected, the electricity consumption amount of the 12-volt battery increases due to controls, such as the system checking, operating. When the AC charging cable is not needed, immediately remove it from the vehicle.

Acoustic Vehicle Alerting System

When driving with the gasoline engine stopped, a sound, which changes in accordance with the driving speed, will be played in order to warn people nearby of the vehicle's approach. The sound will stop when the vehicle speed exceeds approximately 25 km/h (15 mph).

■ Acoustic Vehicle Alerting System

In the following cases, the Acoustic Vehicle Alerting System may be difficult for surrounding people to hear.

- In very noisy areas
- In the wind or the rain

Also, as the Acoustic Vehicle Alerting System is installed on the front of the vehicle, it may be more difficult to hear from the rear of the vehicle compared to the front.

■ When “Acoustic Vehicle Alerting System Malfunction Visit your Dealer” is displayed on the multi-information display

The Acoustic Vehicle Alerting System may be malfunctioning. Have the vehicle inspected by a SUZUKI dealer or a qualified workshop immediately.

Plug-in hybrid system precautions

Take care when handling the hybrid system, as it contains a high voltage system (about 650V at maximum) as well as parts that become extremely hot when the hybrid system is operating. Obey the caution labels attached to the vehicle.

System components

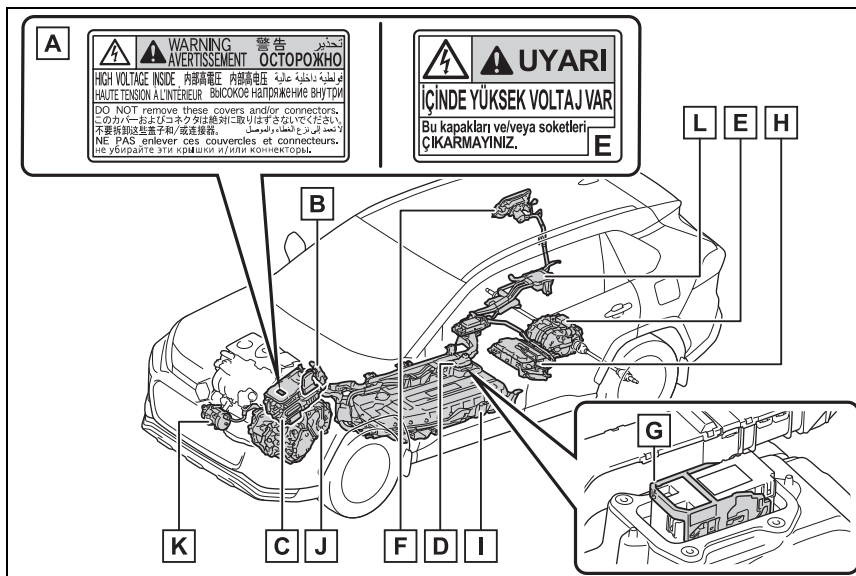

The illustration is an example for explanation and may differ from the actual item.

- A** Caution label
- B** High voltage cables (orange)
- C** Power control unit
- D** DC/DC converter
- E** Rear electric motor (traction motor)
- F** AC charging inlet
- G** Service plug
- H** Onboard traction battery charger

- I Hybrid battery (traction battery)
- J Front electric motor (traction motor)
- K Air conditioning compressor
- L Junction box

■ Running out of fuel

When the vehicle has run out of fuel and the hybrid system cannot be started, refuel the vehicle with at least enough gasoline to make the low fuel level warning light (→P.515) go off. If there is only a small amount of fuel, the hybrid system may not be able to start. (The standard amount of fuel is about 8.8 L [2.3 gal., 1.9 Imp.gal.], when the vehicle is on a level surface. This value may vary when the vehicle is on a slope. Add extra fuel when the vehicle is inclined.)

■ Electromagnetic waves

- High voltage parts and cables on the hybrid vehicles incorporate electromagnetic shielding, and therefore emit approximately the same amount of electromagnetic waves as conventional gasoline powered vehicles or home electronic appliances.
- Your vehicle may cause sound interference in some third party-produced radio parts.

■ Effect of magnetic forces

If objects that generate strong magnetic forces, such as large speakers, are placed inside the luggage compartment or installed nearby, the generated magnetic forces may negatively affect the hybrid system.

■ Hybrid battery (traction battery) (lithium-ion battery)

The hybrid battery (traction battery) has a limited service life.

The hybrid battery (traction battery) capacity (the ability to hold a charge) reduces with time and use in the same way as other rechargeable batteries. The extent at which capacity reduces

changes drastically depending on the environment (ambient temperature, etc.) and usage conditions, such as how the vehicle is driven and how the hybrid battery (traction battery) is charged. This is a natural characteristic of lithium-ion batteries, and is not a malfunction. Also, even though the EV driving range becomes shorter when the hybrid battery (traction battery) capacity reduces, vehicle performance does not significantly become worse.

In order to reduce the possibility of the capacity reducing, follow the directions listed on P.126, "Capacity reduction of the hybrid battery (traction battery)".

■ Starting the hybrid system in an extremely cold environment

When the hybrid battery (traction battery) is extremely cold (below approximately -30°C [-22°F]) under the influence of the outside temperature, it may not be possible to start the hybrid system. In this case, try to start the hybrid system again after the temperature of the hybrid battery increases due to the outside temperature increase etc.

■ Declaration of conformity

This model conforms to hydrogen emissions according to regulation ECE100 (Battery electric vehicle safety).

WARNING

■ High voltage precautions

The vehicle has high voltage DC and AC systems as well as a 12-volt system. DC and AC high voltage is very dangerous and can cause severe burns and electric shock that may result in death or serious injury.

⚠ WARNING

- Never touch, disassemble, remove or replace the high voltage parts, cables or their connectors.
- The hybrid system will become hot after starting as the system uses high voltage. Be careful of both the high voltage and the high temperature, and always obey the caution labels attached to the vehicle.
- Never try to open the service plug access hole located in the luggage compartment. The service plug is used only when the vehicle is serviced and is subject to high voltage.

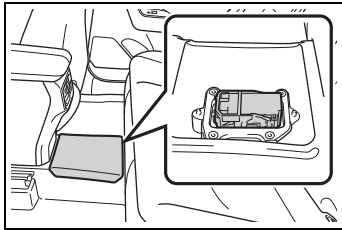

■ Road accident cautions

Observe the following precautions to reduce the risk of death or serious injury:

- Pull your vehicle off the road, apply the parking brake, shift the shift lever to P, and turn the hybrid system off.
- Do not touch the high voltage parts, cables and connectors.
- If electric wires are exposed inside or outside your vehicle, an electric shock may occur. Never touch exposed electric wires.

- Do not touch the battery if liquid is leaking from or adhering to it. If electrolyte (carbonic-based organic electrolyte) from the hybrid battery (traction battery) comes into contact with the eyes or skin, it could cause blindness or skin wounds. In the unlikely event that it comes into contact with the eyes or skin, wash it off immediately with a large amount of water, and seek immediate medical attention.
- If electrolyte is leaking from the hybrid battery (traction battery), do not approach the vehicle. Even in the unlikely event that the hybrid battery (traction battery) is damaged, the internal construction of the battery will prevent a large amount of electrolyte from leaking out. However, any electrolyte that does leak out will give off a vapor. This vapor is an irritant to skin and eyes and could cause acute poisoning if inhaled.
- Do not bring burning or high-temperature items close to the electrolyte. The electrolyte may ignite and cause a fire.
- If a fire occurs in the hybrid vehicle, leave the vehicle as soon as possible. Never use a fire extinguisher that is not meant for electric fires. Using even a small amount of water may be dangerous.
- If your vehicle needs to be towed, do so with front wheels raised. If the wheels connected to the electric motor (traction motor) are on the ground when towing, the motor may continue to generate electricity. This may cause a fire. (→P.503)
- Carefully inspect the ground under the vehicle. If you find that liquid has leaked onto the ground, the fuel system may have been damaged. Leave the vehicle as soon as possible.

**WARNING****Hybrid battery (traction battery)**

- Your vehicle contains a sealed lithium-ion battery.
- Never resell, hand over or modify the hybrid battery. To prevent accidents, hybrid batteries that have been removed from a disposed vehicle are collected through a SUZUKI dealer or a qualified workshop. Do not dispose of the battery yourself. Unless the battery is properly collected, the following may occur, resulting in death or serious injury:
 - The hybrid battery may be illegally disposed of or dumped, and it is hazardous to the environment or someone may touch a high voltage part, resulting in an electric shock.
 - The hybrid battery is intended to be used exclusively with your hybrid vehicle. If the hybrid battery is used outside of your vehicle or modified in any way, accidents such as electric shock, heat generation, smoke generation, an explosion and electrolyte leakage may occur. When reselling or handing over your vehicle, the possibility of an accident is extremely high because the person receiving the vehicle may not be aware of these dangers.
- If your vehicle is disposed of without the hybrid battery having been removed, there is a danger of serious electric shock if high voltage parts, cables and their connectors are touched. In the event that your vehicle must be disposed of, the hybrid battery must be disposed of by a SUZUKI dealer or a qualified workshop, or a qualified service shop. If the hybrid battery is not disposed of properly, it may cause electric shock that can result in death or serious injury.

Caution while driving

If the vehicle under floor area receives strong shock or impact while driving, stop the vehicle in a safe area and check around the bottom of the vehicle. If there is damage to the hybrid battery (traction battery) or liquid leakage, it may lead to a vehicle fire, etc. Do not touch the vehicle and immediately contact a SUZUKI dealer or a qualified workshop.

Modifications

Do not modify the vehicle to make the height lower.

It is easier for the hybrid battery (traction battery) in the under floor area to come in contact with the ground when the vehicle is lowered. If the hybrid battery (traction battery) is damaged, a vehicle fire may occur which could lead to death or serious injury.

**NOTICE****Notice about fuel**

- For plug-in hybrid vehicles, fuel may remain in the tank for a long time and undergo changes in quality depending on the how the vehicle is used. Refuel at least 20 L (5.3 gal., 4.4 Imp.gal.) of fuel every 12 months (refuel a total of at least 20 L [5.3 gal., 4.4 Imp.gal.] over a 12-month period), as this may affect components of the fuel system or the gasoline engine.
- If the vehicle has not been refueled for a certain amount of time and it is possible that the quality of the fuel remaining in the tank has changed, "No New Fuel has been Added Recently Please refuel" is displayed on the multi-information display when the power switch is turned to ON. If the message is displayed, refuel the vehicle immediately.

DC/DC converter air intake vent

There is an air intake vent under the rear seat for cooling the DC/DC converter.

Blocking the air intake vent may prevent the plug-in hybrid system from operating properly.

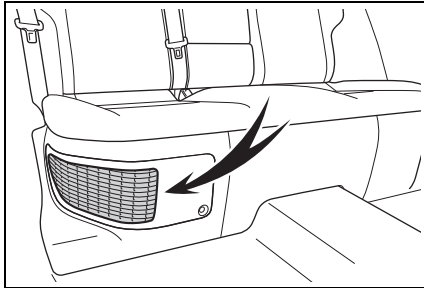

NOTICE

■ DC/DC converter air intake vent

- Make sure not to block the air intake vent with anything, such as a seat cover, plastic cover, or luggage. Blocking the air intake vent may prevent the plug-in hybrid system from operating properly.
- When dust etc. has accumulated in the air intake vent, clean it with a vacuum cleaner to prevent the vent from clogging.
- Do not wet or allow foreign substances to enter the air vent as this may cause a short circuit and damage the DC/DC converter.
- Do not carry large amounts of water such as water cooler bottles in the vehicle. If water spills onto the DC/DC converter, the converter may be damaged. Have the vehicle inspected by a SUZUKI dealer or a qualified workshop.

- A filter is installed to the air intake vent. When the filter remains noticeably dirty even after cleaning the air intake vent, filter cleaning or replacement is recommended. When cleaning the filter, refer to P.477.
- If “Maintenance required for DCDC converter cooling parts See Owner’s Manual” is shown on the multi-information display, the air intake vent and filter may be clogged. Refer to P.477 for information on how to clean the air intake vent.

Emergency shut off system

When a certain level of impact is detected by the impact sensor, the emergency shut off system blocks off the high voltage current and stops the fuel pump to minimize the risk of electrocution and fuel leakage.

If the emergency shut off system activates, your vehicle will not restart. To restart the hybrid system, contact a SUZUKI dealer or a qualified workshop.

Hybrid warning message

A message is automatically displayed when a malfunction occurs in the hybrid system or an improper operation is attempted.

If a warning message is shown on the multi-information display, read the message and follow the instructions.

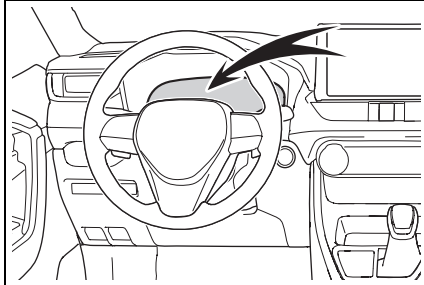

■ **If a warning light comes on, a warning message is displayed or the 12-volt battery is disconnected**

The hybrid system may not start. In that case, try to start the system again. If the "READY" indicator does not come on, contact a SUZUKI dealer or a qualified workshop.

Plug-in hybrid vehicle driving tips

For economical and ecological driving, pay attention to the following points:

Using EV mode, AUTO EV/HV mode and HV mode effectively

Primarily using EV mode and AUTO EV/HV mode when driving in cities and using HV mode when driving on highways (or freeways) can help conserve fuel and electricity. (→P.80)

Using Eco drive mode

When using Eco drive mode, the torque corresponding to the accelerator pedal depression amount can be generated more smoothly than it is in normal conditions. In addition, the operation of the air conditioning system (heating/cooling) will be minimized, improving fuel and electricity economy. (→P.388)

Use of Hybrid System Indicator

Eco-friendly driving is possible by keeping the Hybrid System Indicator within Eco area. (→P.169)

Shift lever operation

Shift the shift lever to D when stopped at a traffic light, or driving in heavy traffic etc. Shift the shift lever to P when parking. When using the N, there is no positive effect on fuel consumption. In the N, the gasoline engine operates but electricity cannot be generated. Also, when using the air conditioning system, etc., the hybrid battery (traction battery) power is consumed.

Accelerator pedal/brake pedal operation

- Drive your vehicle smoothly. Avoid abrupt acceleration and deceleration. Gradual acceleration and deceleration will make more effective use of the electric motor (traction motor) without having to use gasoline engine power.
- Avoid repeated acceleration. Repeated acceleration consumes hybrid battery (traction battery) power, resulting in poor fuel consumption. Battery power can be restored by driving with the accelerator pedal slightly released.

When braking

Make sure to operate the brakes gently and a timely manner. A

greater amount of electrical energy can be regenerated when slowing down.

Delays

Repeated acceleration and deceleration, as well as long waits at traffic lights, will lead to high fuel and electricity consumption. Check traffic reports before leaving and avoid delays as much as possible. When driving in a traffic jam, gently release the brake pedal to allow the vehicle to move forward slightly while avoiding overuse of the accelerator pedal. Doing so can help control excessive electricity and fuel consumption.

Highway driving

- Control and maintain the vehicle at a constant speed. Before stopping at a toll booth or similar, allow plenty of time to release the accelerator and gently apply the brakes. A greater amount of electrical energy can be regenerated when slowing down.
- Electricity consumption will increase significantly when driving at high speeds in EV mode or AUTO EV/HV mode. If there will be a long distance to the next external charging point after leaving a freeway, it is recommended to drive in HV mode while on the freeway and change

to EV mode or AUTO EV/HV mode after leaving the freeway. (→P.80)

Air conditioning

- Turn the “A/C” switch off when it is not needed. Doing so can help reduce excessive electricity and fuel consumption.

In summer: When the ambient temperature is high, use the recirculated air mode. Doing so will help to reduce the burden on the air conditioning system and reduce electricity and fuel consumption as well.

In winter: Avoid excessive and unnecessary use of the heater. Usage of the heated steering wheel (→P.416) and seat heaters (→P.416) are effective.

- Using the Remote Air Conditioning System (→P.413) while the AC charging cable is connected to the vehicle can reduce electricity consumption immediately after starting off by operating air conditioning mainly using electricity from an external power source.
- When setting the charging schedule, setting the charging mode to “Departure” and “Climate Prep” to on can reduce electricity consumption immediately after starting off by operating air conditioning before charging is completed. (→P.136)

Checking tire inflation pressure

Make sure to check the tire inflation pressure frequently. If there is improper tire inflation pressure in the tires, the EV driving range will become shorter, and fuel consumption when in HV mode will increase. Also, as snow tires can cause large amounts of friction, their use on dry roads can lead to increased fuel and electricity consumption.

Luggage

Carrying heavy luggage will lead to poor fuel economy. Avoid carrying unnecessary luggage. Installing a large roof rack will also cause poor fuel economy.

Warming up before driving

Since the gasoline engine starts up and cuts out automatically, warming up is not necessary.

EV driving range

The EV driving range displayed on the multi-information display shows the reference distance that EV driving (driving using only the electric motor) is possible, and the actual distance that can be driven may differ from that displayed.

Even if the EV driving range is displayed, EV driving may be canceled and both gasoline engine and electric motor are used depending on the situation. (→P.84)

Displayed value

The value displayed on the SOC (State of Charge) gauge (→P.166) is estimated from the following information.

- The amount of hybrid battery (traction battery) charge currently remaining
- The electricity consumption (the estimated distance that EV driving is possible per unit of electrical energy) based on the recorded value
- Past air conditioning system electricity consumption amount

The electricity consumption varies depending on how the vehicle is driven. The vehicle automatically records the electricity consumption when being charged and uses the

electricity consumption for estimating the EV driving range. Therefore, the EV driving range displayed when the hybrid battery (traction battery) is fully charged may differ from the previous EV driving range depending on how the vehicle was driven.

The EV driving range may change significantly with each charging until the electricity consumption based on the recorded value is stable (for approximately the first month or two). However, this does not indicate a malfunction.

When the air conditioning system is turned on, the EV driving range (with using the air conditioning system) is estimated based on the past air conditioning electricity consumption amount considering that the electricity consumption may become higher.

Tips for extending the EV driving range

The distance that EV driving is possible varies significantly depending on how the vehicle is driven, road conditions, the weather, the outside temperature, usage conditions of electrical components and the number of occupants.

The distance that EV driving is possible can be extended if the following is performed:

■ **When starting off, depress the accelerator pedal smoothly to accelerate**

As a guide, accelerate up to approximately 20 km/h (12mph) in the first 5 seconds.

Electrical and fuel efficiency can be improved just by using the ECO Accelerator Guidance displayed on the multi-information display and taking care to start off gently. (→P.174)

When the driving mode is set to Eco drive mode, depressing the accelerator pedal generates smooth torque that makes it easier to operate the accelerator gently.

■ **Maintain sufficient vehicle-to-vehicle distance and do not accelerate or decelerate unnecessarily**

Try to maintain a fixed speed while driving. Driving at a short vehicle-to-vehicle distance will result in repeating wasteful acceleration and deceleration, which will worsen the electrical and fuel efficiency.

■ **Release the accelerator pedal early before stopping the vehicle, such as at a traffic light**

The regenerative brake will operate to convert the kinetic energy of the vehicle into electrical energy, which will charge the hybrid battery (traction battery).

The regeneration status can be checked from the Hybrid System Indicator. (→P.169)

When the brake pedal is depressed lightly during deceleration, the regeneration amount increases, enabling more electrical energy to be recovered.

If the brake pedal is depressed too strongly, the recovered amount indicator will reach the maximum level and the upper limit of the recoverable energy will be exceeded. Therefore, be sure to operate the brake pedal early.

■ **Use the air conditioning system appropriately, and also utilize the heated steering wheel and seat heaters**

In EV mode, the vehicle is cooled and heated by electrical energy. (Except in extremely cold temperatures of approximately -10°C (14°F) or less.)

Preventing excessive cooling or heating of the vehicle will reduce power consumption and improve electrical efficiency.

The heated steering wheel and seat heaters are efficient heating device that directly warm the body using less electric power.

When used together with the air conditioning system, a low temperature setting can be used to improve electrical and fuel efficiency.

■ **Check the tire pressure**

If the tire pressure is lower than the specified value, it will worsen the electrical and fuel efficiency.

A pressure level 50 kPa (0.5 kgf/cm² or bar, 7 psi) lower than the specified

value will cause a worsening of several percentage points.

■ **When driving on highways, use the EV/HV mode selection switch to drive in HV mode**

The power consumption will increase significantly if the vehicle is driven in EV mode on highways.

■ **Do not load unnecessary objects in the vehicle**

Driving with objects weighing 100 kg (220 lb.) in the vehicle will worsen the electrical and fuel efficiency by approximately 3%.

Air resistance also greatly affects electrical and fuel efficiency.

Remove any exterior accessories such as a roof luggage carrier when they are not being used.

The running resistance of snow tires is high and they will worsen electrical and fuel efficiency.

Replace them with standard tires as soon as they are no longer needed.

■ **Know your vehicle's electrical and fuel efficiency**

If you know your vehicle's daily electrical and fuel efficiency, you will understand the benefits of Eco drive.

Use the Power Consumption/Fuel Economy, ECO Accelerator Guidance/"Eco Score" and other data displayed on the multi-information display.

Display when charging is completed

The following indicate that charging has been carried out properly.

- The charging indicator of the charging port turns off
- "Charging Complete" is displayed on the multi-information display when a door is opened with the power switch off (→P.124)

Regardless of the type of power source or whether the charging schedule function is used, charging is completed if the above can be confirmed.

Charging-related messages: →P.152

Charging equipment

This vehicle features equipment for connecting to an external power source.

Charging equipment and names

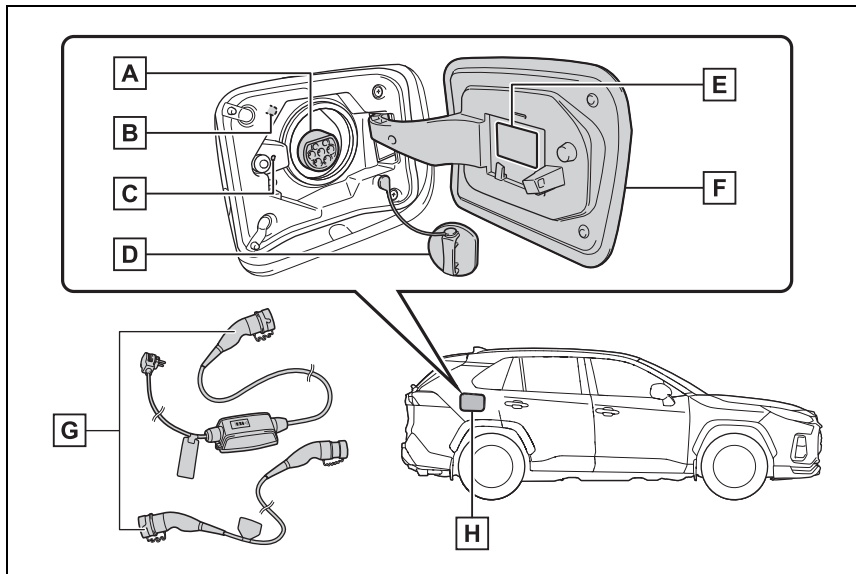

- A** AC charging inlet
- B** AC charging inlet light
- C** Charging indicator (→P.101)
- D** AC charging inlet cap
- E** Caution label/identification label
- F** Charging port lid (→P.100)
- G** AC charging cable* (→P.102)
- H** Charging port

*: The number of equipped AC charging cables may differ depending on the target region.

Opening and closing the charging port lid

■ Opening the charging port lid

Press the central rear edge of the charging port lid (the location shown in the illustration) with the doors unlocked.

Push and take your hand away to slightly open the charging port lid. Then open the lid fully by hand.

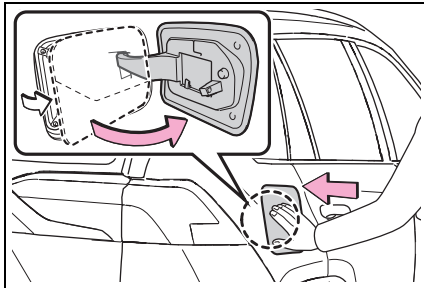

■ Closing the charging port lid

Close the charging port lid and press the central rear edge of the charging port lid (the location shown in the illustration).

When the doors are locked, the charging port lid is also locked.
(→P.114)

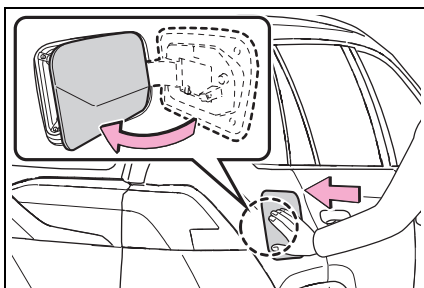

Charging indicator

The illumination/flashing pattern changes to inform the user of the charging status in the following ways.

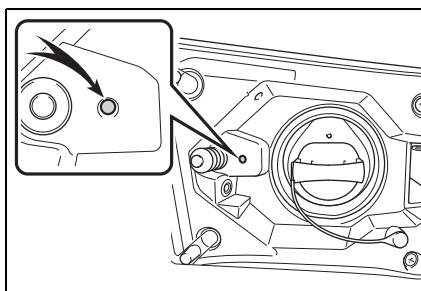

Illumination/flashing pattern	Vehicle condition
Illuminated	<ul style="list-style-type: none"> • Charging is in progress • Charging is possible • “Battery Heater” (→P.121) is operating • “Battery Cooler” (→P.121) is operating
Flashing (normally)*	When charging schedule is registered (→P.136) and AC charging cable is connected to vehicle
Rapidly flashing*	When charging cannot be carried out due to malfunction in a power source or the vehicle etc. (→P.150)
Not illuminated	<ul style="list-style-type: none"> • Charging connector is not inserted into AC charging inlet • When the charging schedule (→P.136) is on standby • When charging is completed

*: Flashes for a certain period of time, and then turns off.

■ Charging indicator of the charging port

When a system malfunction occurs while charging or using the Remote Air Conditioning System, the charging indicator rapidly flashes for a certain period of time, and then turns off.

If this occurs, when a door is opened with the power switch off, a message is displayed on the multi-information display. When a message is displayed, follow the instructions displayed on the screen.

AC charging cable

The function, correct operating procedure, etc. of the AC charging cable are explained.

WARNING

■ When using the AC charging cable and CCID (Charging Circuit Interrupting Device)

Observe the following precautions.

Failure to do so may cause an unexpected accident, resulting in death or serious injury.

- Do not attempt to disassemble or repair the AC charging cable, charging connector, plug or CCID (Charging Circuit Interrupting Device).
If a problem arises with the AC charging cable or the CCID (Charging Circuit Interrupting Device), stop charging immediately and contact a SUZUKI dealer or a qualified workshop.
- Do not subject the AC charging cable, charging connector, plug or CCID (Charging Circuit Interrupting Device) to strong force or impact.
- Do not apply excessive force to the AC charging cable by forcefully folding, twisting, pulling or dragging the AC charging cable.
- Do not damage the AC charging cable with sharp objects.
- Do not fold the charging connector or plug or insert foreign objects into them.
- Do not put the charging connector and plug into water.
- Do not bring the AC charging cable to a high-temperature item such as a heating device.

- Do not apply a load to the AC charging cable and plug-cord (such as wrapping the AC charging cable around the CCID (Charging Circuit Interrupting Device) and the charging connector).
- Do not use or leave the AC charging cable in situations where a load is applied to the socket and the plug (such as when the CCID (Charging Circuit Interrupting Device) is hanging in the air without contacting the ground).
- Mode 3 AC charging cable: Do not use outside the rated voltage (less than 277 V) or rated current (less than 20 A).

NOTICE

■ Precautions when handling AC charging cable

Make sure to observe the following precautions. Failure to observe these precautions may result in damage to the AC charging cable and AC charging inlet.

- Insert the charging connector straight into the AC charging inlet.
- After inserting the charging connector, do not apply excessive force to or twist the connector. Also, do not lean on the connector or hang any objects from it.
- Do not step on or trip over the AC charging cable.
- Before removing the charging connector, make sure that it is unlocked. (→P.114)
- After removing the AC charging cable, promptly return it to its proper location.
- After removing the charging connector, securely install the AC charging inlet cap.

 **NOTICE**

■ **When using the AC charging cable and related parts**
→P.128

■ **Precautions for low temperatures**
In low temperatures, the AC charging cable and plug-cord may become hard.
Therefore, make sure to not apply excessive force when they are hard. If excessive force is applied to the hardened AC charging cable and plug-cord, they may be damaged.

The names of each part of the AC charging cable

► Mode 2 AC charging cable

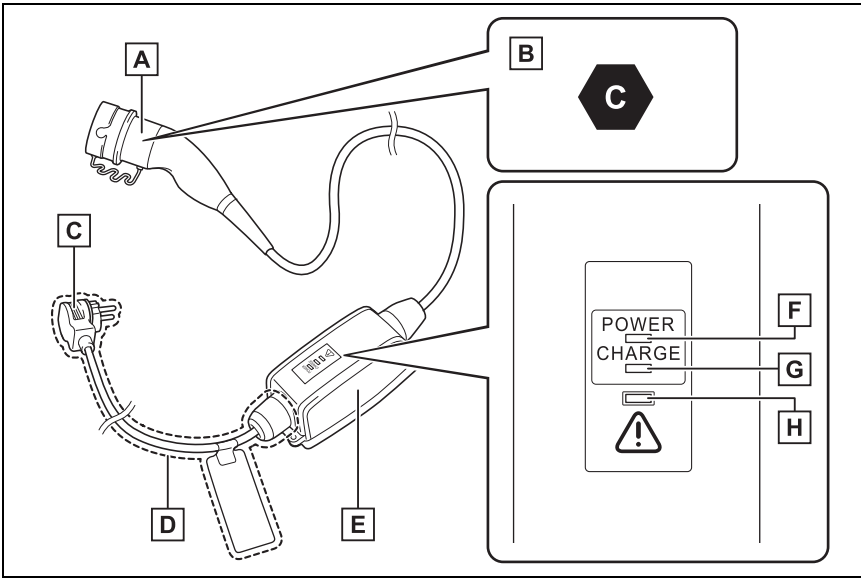

- A** Charging connector
- B** Identification label
- C** Plug
- D** Plug-cord

2
Plug-in hybrid system

- E** CCID (Charging Circuit Interrupting Device)
- F** Power indicator (→P.107)
- G** Charging indicator (→P.107)
- H** Error warning indicator (→P.107)
- ▶ Mode 3 AC charging cable (if equipped)

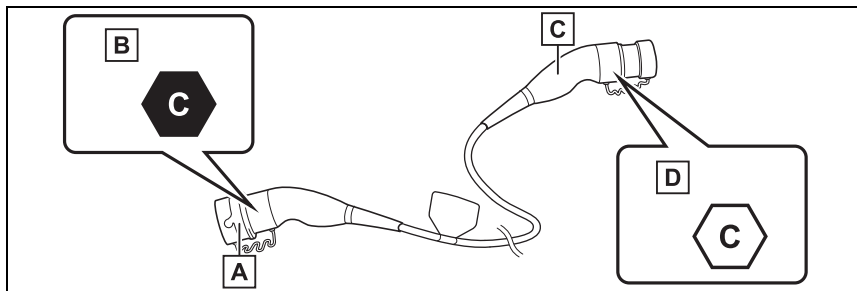

- A** Charging connector (vehicle side)
- B** Identification label (on the charging connector)
- C** Charging plug (charger side)
- D** Identification label (on the charging plug)

■ **AC charging cable types**





The following charging modes are categorized according to the availability of a charging control device, which detects malfunctions such as electrical leakages, and its location (whether it is attached to the charger or AC charging cable). The type of AC charging cable that can be used differs according to the charging mode

Charging mode	Outline
Mode 1	A charging method which does not use charging control to detect electrical leakages between an external power source and the vehicle. Does not apply to this vehicle.
Mode 2	A charging method which connects the vehicle to an external power source through a AC charging cable equipped with a CCID (Charging Circuit Interrupting Device). Applies to charging through most household sockets.
Mode 3	A charging method which charges from a charger (such as at a public charging station) equipped with charging control to detect electrical leakages. Control to detect electrical leakages is implemented on the charger side. Therefore, a CCID (Charging Circuit Interrupting Device) is not equipped to the AC charging cable. Not all chargers are equipped with AC charging cables. If there is no AC charging cable available, use the Mode 3 AC charging cable equipped to this vehicle. (if equipped)

■ Identification label

Identification labels are attached to the vehicle, AC charging cable and charger to inform the user of which device they should use.

The meaning of the each identification label is as follows:

Identifica- tion label	Supply type	Standard	Configura- tion	Type of accessory	Voltage range
	AC	EN 62196-2	TYPE 2	•Charging port lid •Charging con- nector	≤ 480V RMS
	AC	EN 62196-2	TYPE 2	•Charging plug •Charger	≤ 480V RMS
	DC	EN 62196-3	FF	•Charging port lid •Charging con- nector	50V to 500V
	DC	EN 62196-3	AA	•Charging port lid •Charging con- nector	50V to 500V

2
Plug-in hybrid system

Grounding (Mode 2 AC charging cable)

This product must be grounded. In case of malfunction or break down, grounding provides a path of least resistance for electric current to reduce the risk of electric shock. This product is equipped with a grounding conductor and a grounding plug. The grounding plug must be plugged into an appropriate socket that is properly installed and grounded in accordance with all local codes and ordinances.



WARNING

■ Grounding precautions

- Improper connection of the grounding conductor increases the risk of electric shock. Check with a qualified electrician or serviceman if you are in doubt as to whether the product is properly grounded.
- Do not modify the grounding plug provided with the product. If it does not fit the socket, have a proper socket installed by a qualified electrician.

Safety functions (Mode 2 AC charging cable)

The CCID (Charging Circuit Interrupting Device) has the following safety features.

■ Electrical leakage detection function

If an electrical leakage is detected during charging, the power source

will be automatically interrupted, thus preventing fires or electrical shocks caused by electrical leakage.

If the power source is interrupted, the error warning indicator flashes.

If the power source is interrupted:
→P.107

■ Automatic check function

This is an automatic system check that is run before charging begins to check for problems in the operation of the electrical leakage detection function.

If a malfunction is found in the electrical leakage detection function as a result of the check, the error warning indicator flashes to inform the user. (→P.107)

■ Temperature detection function

A temperature detection function is equipped to the plug. While charging, if heat is generated due to looseness on the socket side etc., this function suppresses heat by controlling the charging current.

■ Conditions for supplying current to the vehicle

The CCID (Charging Circuit Interrupting Device) is designed to prevent electrical current from being supplied to the charging connector when it is not connected to the vehicle, even if the plug is inserted into the socket.

CCID (Charging Circuit Interrupting Device) indicators (Mode 2 AC charging cable)

■ **Indicator operation**

3 indicators are used to indicate the following conditions.

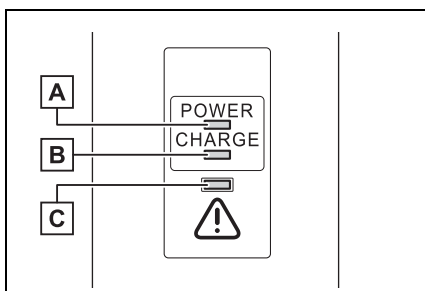

A Power indicator

Illuminates when electricity is flowing to the CCID (Charging Circuit Interrupting Device).

B Charging indicator

Illuminates when charging is in progress.

C Error warning indicator

Flashes when there is an electrical leakage or when a malfunction occurs in the CCID (Charging Circuit Interrupting Device).

■ **When a malfunction occurs during charging**

The indicators on the CCID (Charging Circuit Interrupting Device) use a combination of different statuses (not illuminated, illuminated or flashing) to inform the user of internal malfunctions.

When the error warning indicator is illuminated or flashing, temporarily remove the plug from the socket and then reconnect it to check if the error indicator turns off.

If the error warning indicator turns off, charging is now possible.

If it does not turn off, perform the correction procedure in the following chart.

Status	Power indicator	Error warning indicator	Cause/Correction procedure
Charging system error	Not illuminated	Not illuminated or illuminated	An electrical leakage is detected and charging is canceled, or there is a malfunction in the AC charging cable.
	Illuminated	Flashes	→ Consult a SUZUKI dealer or a qualified workshop
Plug temperature detection malfunction	Flashes	Flashes	There is a malfunction in the plug temperature detection part.*1 → Consult a SUZUKI dealer or a qualified workshop

Status	Power indicator	Error warning indicator	Cause/Correction procedure
Plug temperature increase detection	Flashes	Not illuminated	An increase in the temperature of the plug is detected due to an improper connection between the socket and plug. ^{*2} → Check that the plug is securely connected to the socket
AC charging cable life span notice	Illuminated	Flashes	The number of charges using the AC charging cable is nearing the end of its usable life span. → Consult a SUZUKI dealer or a qualified workshop
AC charging cable life span	Illuminated	Illuminated	The number of charges using the AC charging cable has exceeded its usable number of charges. → Consult a SUZUKI dealer or a qualified workshop

*1: When this occurs, charging is carried out without a limited charging current.

*2: When this occurs, charging is carried out with a limited charging current.

Replacing the plug-cord (Mode 2 AC charging cable) (if equipped)

The plug-cord can be replaced using the following procedure.

- 1 Prepare the AC charging cable (→P.103) and the replacement plug-cord.

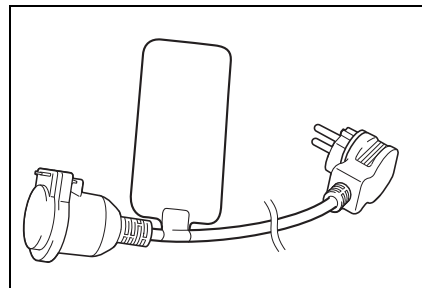

- 2 Pull out the release key.

Make sure that the pulled out release key is not lost.

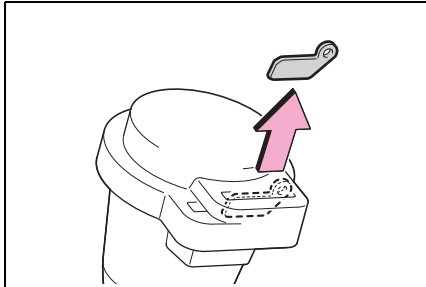

3 Remove the plug-cord connector cap.

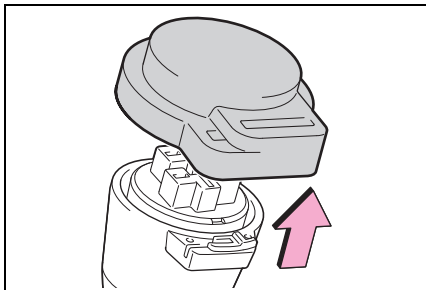

4 Insert the release key into the release slot of the CCID (Charging Circuit Interrupting Device).

Insert the release key in the direction shown in the illustration.

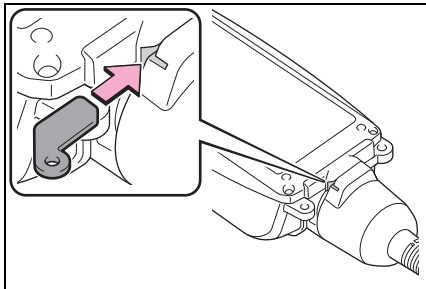

5 With the release key fully inserted into the release slot of the CCID (Charging Circuit Interrupting Device), turn the

plug-cord connector nut of the plug-cord to remove the cord.

After the plug-cord is removed, remove the release key.

Do not leave the vehicle alone with the plug-cord removed. If the plug-cord is not installed, water or other foreign matter may enter the CCID (Charging Circuit Interrupting Device), resulting in a malfunction.

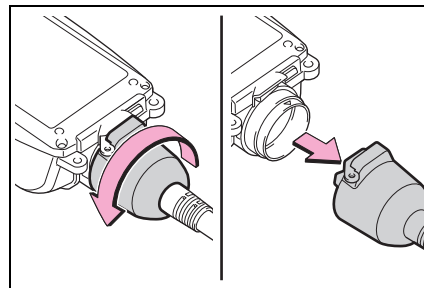

6 Align the protrusion of the CCID (Charging Circuit Interrupting Device), with the groove of the plug-cord, insert the plug-cord into the CCID (Charging Circuit Interrupting Device), and then turn the plug-cord connector nut of the plug-cord to install it.

Make sure that there are no foreign objects attached to the connection before installing the plug-cord. Remove any foreign objects if they are attached. Otherwise, water or other foreign matter may enter the CCID (Charging Circuit Interrupting Device), resulting in a malfunction.

Turn the plug-cord connector nut of the plug-cord in the opposite direction of removal until a click sound is heard and the plug-cord is secured.

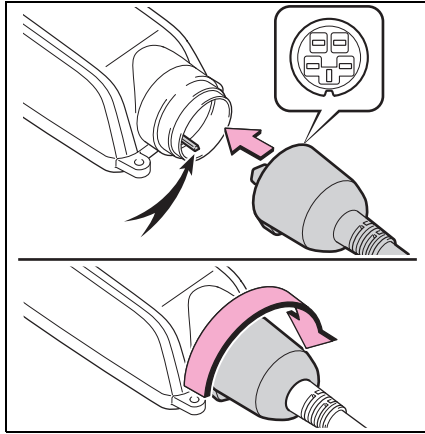

7 Install the plug-cord connector cap and release key to the plug-cord that has been removed.

Securely install the release key to the plug-cord connector cap to prevent it from being lost. Also, make sure that the release key does not fall out of the plug-cord connector cap accidentally.

Store the plug-cord in a safe, clean and dry place.

⚠ WARNING

■ **When replacing the plug-cord (if equipped)**

Check the following points regularly. Failure to do so may cause an unexpected accident, resulting in death or serious injury.

- Do not replace the plug-cord with wet hands. Also, do not replace in a place that is rainy or wet.
- Do not replace the plug-cord when the plug and/or charging connector are connected.
- Check whether there are any local EV-charging regulations in place, and adhere to them.

- Do not leave the CCID (Charging Circuit Interrupting Device) with the plug-cord removed.

- Make sure that there are no foreign objects attached to the connection when installing the plug-cord to the CCID (Charging Circuit Interrupting Device).

- When replacing the plug-cord, firmly turn the nut of the plug-cord until a click sound can be heard.

- Do not replace the plug cord in Norway.

⚠ NOTICE

■ **Precautions for the plug-cord (if equipped)**

Do not use the plug-cord for any use other than charging this vehicle. Doing so may cause the plug-cord to be damaged.

Inspecting and maintaining the AC charging cable

For safety, inspect the AC charging cable on a routine basis.

⚠ WARNING

■ **Routine inspection**

Check the following points regularly. Failure to do so may cause an unexpected accident, resulting in death or serious injury.

- The AC charging cable, plug, charging connector, CCID (Charging Circuit Interrupting Device) etc. have not been damaged.
- The socket has not been damaged.
- The plug can be securely inserted into the socket.

**WARNING**

- The plug does not get extremely hot during use.
- The tip of the plug has not been deformed.
- The plug is not dirtied by dust etc. Remove the plug from the socket before inspecting it. If any abnormalities are found in the AC charging cable as a result of the inspection, immediately stop use and consult a SUZUKI dealer or a qualified workshop.

■ Maintaining the AC charging cable

When the AC charging cable is dirty, first remove the dirt with a hard, wringed cloth, and then wipe the cable with a dry cloth.

However, never wash it with water. If the AC charging cable is washed with water, fire or electric shock may occur during charging, possibly resulting in death or serious injury.

■ When not using the AC charging cable for a long time

Remove the plug from the socket. Dust could accumulate on the plug or in the socket, possibly causing overheating which could lead to a fire.

Also, keep the cable in a place free from moisture.









2







Plug-in hybrid system

Appendix (Mode 2 AC charging cable)**■ Rating**



- Voltage (Un): 220 V - 240 V ~
- Frequency: 50 Hz / 60 Hz 1Φ
- Current: 10 A
- Residual operating current (IΔn): 6 mA
- Ambient temperature: -30°C to 55°C
- IP67

■ Warning symbols



	<p>This device is for use with electric vehicles. (This device does not require ventilation)</p>
	<p>Do not attempt to disassemble or repair the AC charging cable, charging connector, plug or CCID (Charging Circuit Interrupting Device).</p>
	<p>There may be a risk of electrical shock when using this device improperly.</p>
	<p>If the plug, charging connector or CCID (Charging Circuit Interrupting Device) is abnormally hot during use, unplug it immediately.</p>
	<p>Connecting the AC charging cable to an extension cord is strictly prohibited.</p>
	<p>Do not connect the device to a socket that is loose, worn, or broken. Ensure the plug fits the socket tightly.</p>
	<p>When the plug is used with a rain-tight socket for outdoor use, protect the plug and socket from rain and snow by using a rain-tight cover.</p>
	<p>Do not immerse the plug or cord in water or other liquid. Do not expose the plug to rain and snow.</p>
	<p>To reduce the risk of electric shock, connect only to a properly grounding type socket.</p>

  <p>OK hook</p>	<p>Do not hang the CCID (Charging Circuit Interrupting Device) on the plug. Ensure the CCID (Charging Circuit Interrupting Device) is supported.</p>
 	<p>Do not subject the AC charging cable, charging connector, plug or CCID (Charging Circuit Interrupting Device) to strong force or impact.</p>
	<p>Do not place heavy objects on the AC charging cable, charging connector, plug or CCID (Charging Circuit Interrupting Device).</p>
	<p>Do not use this device if the AC charging cable is frayed, has broken insulation, or any other signs of damage.</p>

■ Caution symbols

 	<p>Do not wind the power cord or AC charging cable around the CCID (Charging Circuit Interrupting Device) or charging connector.</p>
--	--

■ Information symbols

	<p>This device may not operate if used with IT or other unearthed systems such as an isolated winding generator or isolating transformer.</p>
	<p>This device has a non-switched protective conductor.</p>
 <p>≤4000m</p>	<p>Do not use this device at an altitude over 4000 meter.</p>

Locking and unlocking the charging port lid and charging connector

The charging port lid and charging connector can be locked/unlocked by the following procedures.

- Using the smart entry & start system* : →P.191
- Using the wireless remote control* : →P.189

*: If the smart entry & start system or the wireless remote control does not operate properly, use the mechanical key. (→P.533)

Locking and unlocking the charging port lid

■ Unlocking the charging port lid

- 1 Unlock the doors using the smart entry & start system or wireless remote control.
- 2 Press the central rear edge of the charging port lid (the location shown in the illustration) and open it.

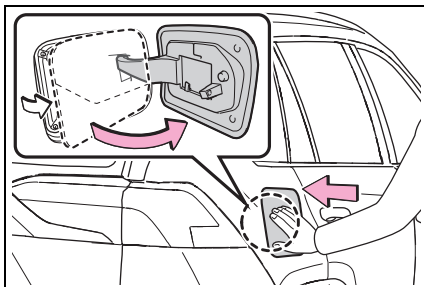

■ Locking the charging port lid

The charging port lid will be locked when the lid is closed and the doors are locked using the smart entry & start system or wireless remote control.

■ Security feature

If a door or charging port lid is not opened within approximately 30 seconds after the vehicle is unlocked, the security feature automatically locks the lid again when the doors are automatically locked. (→P.192)

■ Locking the charging port lid

If the charging port lid is closed after the doors are locked, the lid will not be locked. In this case, close the lid and then lock the doors again.

■ If the charging port lid does not open

If the charging port lid does not open when using the normal procedure, it can be opened in an emergency by performing the following steps.

- 1 Open the back door. (→P.197)
- 2 Pull the luggage side cover and remove it. (→P.451)
- 3 Hook a finger to the emergency release lever as shown in the illustration.

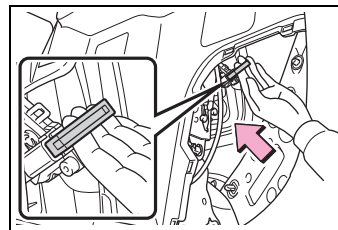

- 4 Move the emergency release lever in the direction shown in the illustration.*

The charging port lid is unlocked and can be opened.

*: Make sure to move in the direction

shown in the illustration. Applying force in other directions may damage the emergency release lever.

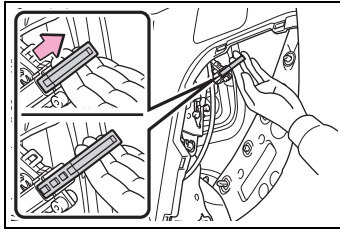

- 5 Press the central rear edge of the charging port lid to open it. (→P.100)

This unlocking method is a temporary correction procedure for emergency use only. If the problem persists, have the vehicle inspected by a SUZUKI dealer or a qualified workshop immediately.

Locking and unlocking the charging connector

■ Locking the charging connector

The charging connector will be automatically locked when inserting it into the AC charging inlet.

■ Unlocking the charging connector

The charging connector will be unlocked when the doors are unlocked using the smart entry & start system or wireless remote control.

■ Charging connector lock function

The charging connector lock function does not guarantee that theft of the AC charging cable will be prevented, and is not necessarily effective for all mischiefs.

■ Unlocking the charging connector using the smart entry & start system

If the charging connector is locked while the doors are unlocked, lock and then unlock the doors to unlock the charging connector.

■ Security function for unlocking

If the charging connector is not removed within approximately 30 seconds after the vehicle is unlocked, the security function automatically locks the connector again.

■ Unlocking the charging connector during charging

If the charging connector is unlocked during charging, charging will be stopped. Once the security function (→P.115) works, charging may not restart automatically. In this case, remove the charging connector* and insert it again.

*: When the charging connector is removed, the charging schedule will be updated. (→P.136)

■ When the charging connector cannot be inserted into the AC charging inlet

Check that the connector lock pin is not lowered.

If the connector lock pin is lowered, the connector lock is operating. Unlock the doors using the smart entry & start system or wireless remote control and unlock the charging connector lock and check that the connector lock pin is not lowered.

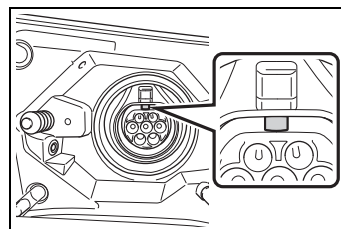

■ **If the charging connector cannot be unlocked**

The charging connector can be unlocked by operating the emergency release lever.

- 1 Open the back door. (→P.197)
- 2 Remove the cover as shown in the illustration.

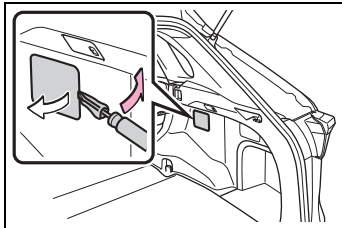

- 3 Insert a hand from the lower side of the vehicle obliquely upward, and hook a finger to the emergency release lever.

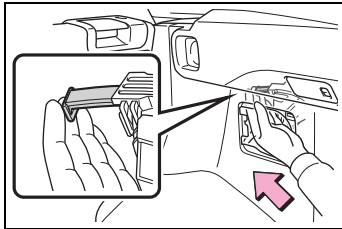

- 4 Move the emergency release lever in the direction shown in the illustration.*

The charging connector is unlocked and can be removed.

*: Make sure to move in the direction shown in the illustration. Applying force in other directions may damage the emergency release lever.

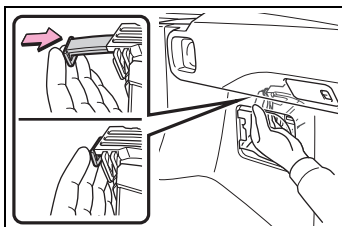

- 5 Reinstall the cover to its original position.

This method is a temporary correction procedure for emergency use only. If the problem persists, have the vehicle inspected by a SUZUKI dealer or a qualified workshop immediately.

Do not operate the emergency release lever when the charging connector can be unlocked in the normal procedure.

WARNING

■ **When connecting the charging connector to the AC charging inlet**

Be careful not to touch the charging port lid lock portion. When the connector lock operates, the charging port lid lock will also operate. The charging port lid lock pin may hit a hand, resulting in an injury.

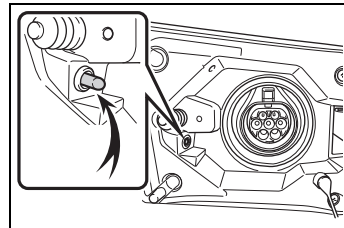

NOTICE

■ **When inserting the charging connector**

Observe the following precautions. Failure to do so may cause a malfunction in the charging connector locking system.

- Check that the charging connector is compatible with this vehicle. A charging connector of the different type or a charging connector with damaged or deformed insertion part may not be locked.

 **NOTICE**

- Do not apply excessive force to the charging connector after the charging connector is inserted. When removing the charging connector, make sure to unlock the charging connector.

Power sources that can be used

An external power source that fulfills the following criteria is necessary for charging this vehicle. Confirm this before charging.

 **WARNING**

■ **Warnings for electrical faults**

Make sure to observe the precautions in this Owner's Manual when charging the vehicle.

Failure to use a power source that fulfills the requirements, or failure to observe regulations while charging could lead to an accident, possibly resulting in death or serious injury.

Power sources

- Connect to an AC 220 V - 240 V socket with a Residual Current Circuit-Breaker (RCCB) and a circuit breaker. Use of a 13A individual circuit is strongly recommended to ensure AC charging cable will operate properly.
- We strongly recommend that you use an exclusive connection from the junction box for charging. If you connect on a socket that is on a shared circuit, and other electrical appliances are used on other sockets on the same circuit, then the circuit breaker might trip.*
- Ensure that the junction box is equipped with a Residual Cur-

2

Plug-in hybrid system

rent Circuit-Breaker (RCCB). If it is not, have one installed by a duly qualified professional.

- When charging outdoors, make sure to connect to a rain-tight socket that is certified for outdoor use. Checking Residual Current Circuit-Breaker (RCCB) operation before its use is recommended.
- Check whether there are any local EV-charging regulations in place, and adhere to them.

*: For detailed information, consult an electrician.

■ **The charging environment**

For safe charging, the following charging equipment and settings are recommended.

● **Rain-tight socket**

When charging outdoors, connect the plug to a rain-tight socket, and ensure that the plug remains waterproof while the plug is connected.

● **Dedicated circuit**

- To reduce the risk of fire, connect only to an at least 13A branch circuit with an over-current protection.
- To reduce the risk of electric shock when working with the plug, connect to a socket that has a Residual Current Circuit-Breaker (RCCB) installed.

● **Remote switch**

Allows the electricity from the socket to be interrupted by operating a switch, thus allowing safe removal and insertion of the plug on rainy days.

■ **When your circuit breaker trips during charging**

The upper limit of the charging current can be changed in “Vehicle Settings” on

the multi-information display.

- 1 Press or of the meter control switches to select .
- 2 Press or of the meter control switches to select “Vehicle Settings”, and then press and hold .
- 3 Press or of the meter control switches to select “Charging Settings”, and then press . The “Charging Settings” screen will be displayed.
- 4 Press or of the meter control switches to select “Charging Current”, and then press . The “Charging Current” screen will be displayed.
- 5 Press or of the meter control switches to select “8A”, and then press . The maximum charging current during charging will be restricted to 8A.*

If the breaker still trips while charging, even after changing the upper limit of the charging current, check if the connected power source meets the specified charging conditions. (→P.117)

*: Restricting the charging current will lengthen the charging time.

WARNING

■ **Power sources precautions**

Observe the following precautions. If you do not follow them, fire, electrical shock and/or damages may occur, possibly resulting in death or serious injury.

⚠ WARNING

- Connect to an AC 220 V - 240 V socket with a Residual Current Circuit-Breaker (RCCB) and supplied by a circuit breaker in line with local regulations. Use of an individual circuit provided with at least 13A is strongly recommended.
- Do not connect the AC charging cable to a multi-socket adaptor, multi-plugs, or conversion plug.

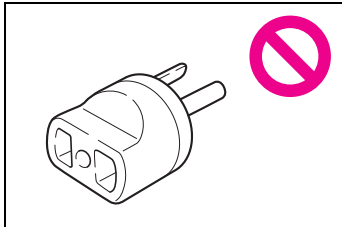

- Connecting the AC charging cable to an extension cord is strictly prohibited. The extension cord may overheat and does not contain a Residual Current Circuit-Breaker (RCCB). The leakage detection function of the CCID (Charging Circuit Interrupting Device) (→P.106) may not operate correctly.

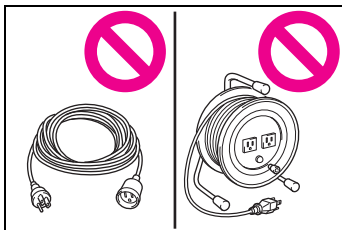

- Do not connect to a power strip.

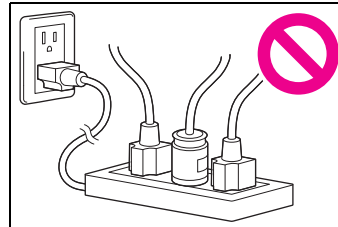

- Use of a block heater socket which fails to meet the requirements is prohibited for charging.
- Make sure to connect the charging connector and AC charging inlet directly. Do not connect a converting adaptor or extension cord between the charging connector and AC charging inlet.

Charging methods

The following methods can be used to charge the hybrid battery (traction battery).

Types of charging methods

■ Charging from an external power source (→P.128)

This is a charging method used when charging from an AC socket (220 V - 240 V) with the AC charging cable equipped to the vehicle or charging at a public charging station.

The charging start time (or departure time) and day can be set to carry out charging using the charging schedule at the desired date and time. (→P.136)

■ Using the hybrid battery (traction battery) charge mode (→P.81)

The plug-in hybrid system can be switched to hybrid battery (traction battery) charge mode to charge the hybrid battery (traction battery) using electricity generated by gasoline engine operation.

The maximum charge amount in the hybrid battery (traction battery) charge mode is approximately 80% of the fully charged capacity for the charging from an external power source.

Estimated charging time

The time required to charge the hybrid battery (traction battery) dif-

fers according to the charging voltage and charging current.

- Home power source (except for France, Finland and Switzerland)

Charging voltage^{*1}: AC 230 V

Charging current^{*2}: 10A

Estimated charging time^{*3, 4}: Approximately 7 hours 30 minutes

- Home power source (for France, Finland and Switzerland)

Charging voltage^{*1}: AC 230 V

Charging current^{*2}: 8A

Estimated charging time^{*3, 4}: Approximately 9 hours

- Charging station

Charging voltage^{*1}: AC 230 V

Charging current^{*2}: 16A

Estimated charging time^{*3, 4}: Approximately 5 hours

^{*1}: The charging voltage may differ depending on the target region.

^{*2}: This is the maximum value. Furthermore, the upper limit of the charging current can be changed in "Vehicle Settings". (→P.118)

^{*3}: The time required to complete charging depends on conditions such as the remaining charge of the hybrid battery (traction battery), the outside temperature and specifications of a charger (charging station).

^{*4}: When using "My Room Mode" (→P.145), the time required for charging to complete may be longer or the charging may not be completed.

■ Charging time may increase

In the following situations, charging time may become longer than normal:

- In very hot or very cold temperatures.
- When the hybrid battery (traction battery) becomes hot, such as immediately after high-load driving.
- The vehicle is consuming a lot of electricity, for example, when the headlights are on etc.
- When using “My Room Mode”. (→P.145)
- There is a power outage during charging.
- There is an interruption in the electrical supply.
- There is a drop in the voltage of external power source.
- The charge in the 12-volt battery is low, for example due to the vehicle being left unused for a long period of time.
- The maximum charging current is set to 8A through “Vehicle Settings”. (→P.118)
- When the “Battery Heater” operates. (→P.121)
- When the “Battery Cooler” is operated before charging. (→P.121)
- When the plug generates heat due to a loose socket connection etc.

■ Using a DC Charger

DC Chargers cannot be used with this vehicle.

■ Charging electricity

This vehicle can be charged up to approximately 3.3 kW.

However, depending on the used charger or AC charging cable, charging electricity may be limited.

Charging-linked functions

This vehicle is equipped with sev-

eral functions that are linked with charging.

■ “My Room Mode” (→P.145)

When the AC charging cable is connected to the vehicle, electrical components such as the air conditioning system or audio system can be used using the external power source*.

*: The power of the hybrid battery (traction battery) may be used depending on the situation.

■ “Battery Heater”

When the outside temperature is low and the AC charging cable is connected to the vehicle, this function automatically warms the hybrid battery (traction battery) until it reaches or exceeds a certain temperature.

“Battery Heater” will operate when the “Battery Heater” of the “Charging Settings” on the multi-information display is on. (→P.179)

■ “Battery Cooler”

When the hybrid battery (traction battery) is hot and the AC charging cable is connected to the vehicle, this function cools the hybrid battery (traction battery) before charging is carried out.

“Battery Cooler” will operate when the “Battery Cooler” of the “Charging Settings” on the multi-information display is on. (→P.179)

■ Traction battery heating and cooling system (“Battery Heater” and “Battery Cooler”)

- The system operates when the hybrid battery (traction battery) is below or above a certain temperature.
- The system may operate when charging is not being performed.
- When the charging schedule is used (→P.136), this function will operate according to the charging schedule.

■ “Battery Heater”

- When “Battery Heater” is operating, the charging indicator illuminates.
- When the AC charging cable is removed from the vehicle or remains connected to the vehicle for approximately 3 days, the system automatically stops.
- When “Battery Heater” is operating during charging, the charging time may be longer than normal.
- If the outside temperature becomes high while “Battery Heater” is operating, charging may complete earlier than the “Departure” time set. (→P.136)
- When the traction battery is almost completely charged, “Battery Cooler” may not be implemented.
- When the following operations are performed while “Battery Heater” is operating, the hybrid battery (traction battery) heating operation stops.
 - The shift lever is changed to any position other than P
 - The Remote Air Conditioning System is operated (→P.413)
- “Battery Heater” may operate even when the hybrid battery (traction battery) is fully charged depending on the temperature of the hybrid battery (traction battery).
 - The remaining charge of the hybrid battery (traction battery) decreases when “Battery Heater” operates. The charging operation may start again to

charge the hybrid battery (traction battery).

- “Charging Stopped Due to Pulled Charging Connector” may be shown when the charging connector is removed while recharging. (→P.152)

■ “Battery Cooler”

- The charging indicator is illuminated while “Battery Cooler” is on standby or operating.
- “Battery Cooler” is implemented for a maximum of approximately 30 minutes. However, when the “Departure” time is set (→P.136) and there is not sufficient time between the current time and the time that charging will complete, “Battery Cooler” operation time may become shorter.
- When there is a small amount of remaining charge in the hybrid battery (traction battery), even if the hybrid battery (traction battery) is hot, “Battery Cooler” may not be implemented.
- When the following operations are performed while “Battery Cooler” is operating, the hybrid battery (traction battery) cooling operation stops.
 - The hood is opened
 - The power switch is turned to any mode other than off
 - The Remote Air Conditioning System is operated (→P.413)
 - “Charge Now” is implemented (→P.137)
- “Battery Cooler” uses the power of the hybrid battery (traction battery) and external power source.
 - While “Battery Cooler” is operating, the amount of the remaining charge of the hybrid battery (traction battery) increases and decreases in a certain range, and does not increase as in normal charging.
 - The operation of “Battery Cooler” is recognized as charging by a charger. The charger that calculates the fee according to charging time causes a charging fee.

Charging tips

This section explains methods for using the charging function for this vehicle and checking information related to charging.

Systematically charging

To enable the use of EV mode or AUTO EV/HV mode, we recommend systematically charging the vehicle.

■ Before leaving home

In order to use EV mode or AUTO EV/HV mode, charge the hybrid battery (traction battery) at home before leaving.

The charging schedule function (→P.136) can be used to set the system to automatically fully charge the hybrid battery (traction battery) before your desired departure time. It is also possible to set the air conditioning to make the interior in a comfortable state before your desired departure time.

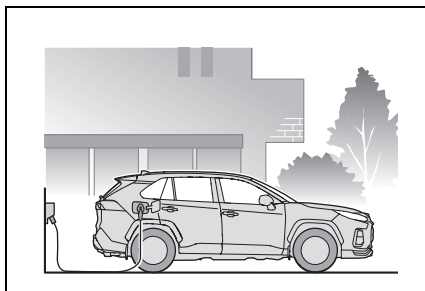

■ At your destination

Use a public charging station to charge the hybrid battery (traction

battery).

If there are no charging facilities at your destination, the hybrid battery (traction battery) can be charged using the hybrid battery (traction battery) charge mode. (→P.81)*

*: When using the hybrid battery (traction battery) charge mode while parked, make sure that no flammable objects are near the vehicle and the vehicle is parked in a well-ventilated area. (→P.82)

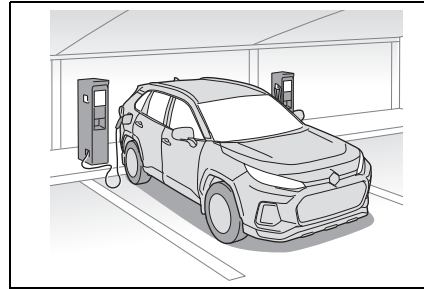

■ After returning home

In order to drive the next time, charge the hybrid battery (traction battery).

Setting the charging schedule allows you to charge the hybrid battery (traction battery) at the desired time such as late at night or early in the morning. Furthermore, the charging schedule can be set to automatically charge the hybrid battery (traction battery) every day or at the same time on certain days. (→P.136)

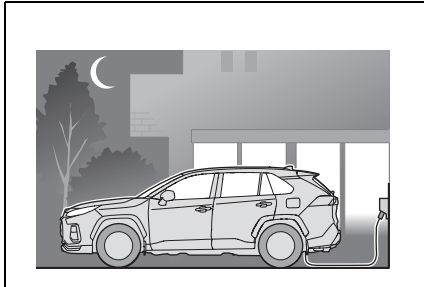

Checking information related to charging

Information related to charging is displayed and can be checked on the multi-information display.

■ While charging

When any door is opened during charging, the current charging condition and approximate time remaining until charging is complete are displayed for a certain period of time.

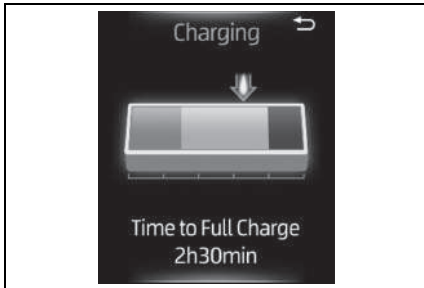

■ After charging is complete

When any door is opened with the power switch off after charging is complete, a message detailing the results of the charging is displayed for a while. Also, a message is displayed if an operation that stops charging is performed or a situation

where charging cannot be performed occurs.

When a message is displayed, follow the instructions displayed on the screen. (→P.152)

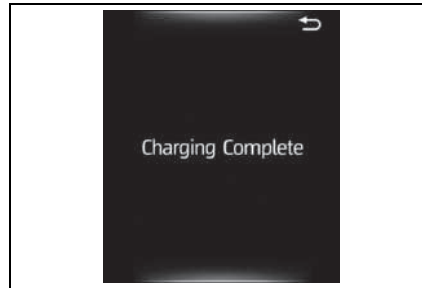

■ Multi-information display during charging

If approximately 100 seconds elapse after the power switch is turned to ON during charging, the power switch will automatically turn off and the display will disappear.

Things to know before charging

Make sure to read the following precautions before connecting the AC charging cable to the vehicle and charging the hybrid battery (traction battery).

■ Safety functions

- The hybrid system will not start while the AC charging cable is attached to the vehicle, even if the power switch is operated.
- If the AC charging cable is connected while the "READY" indicator is illuminated, the hybrid system will stop automatically and driving will not be possible.

WARNING

■ Caution when charging

People with implantable cardiac pacemakers or cardiac resynchronization therapy-pacemakers should not carry out the charging procedure. Ask someone else to do it.

- Do not approach the charger and AC charging cable while charging. Charging procedure may affect the operation of such devices.
- Do not remain in the vehicle during charging. Charging procedure may affect the operation of such devices.
- Do not enter the vehicle even to take something out of the luggage compartment. Charging procedure may affect the operation of such devices.

■ When the AC charging cable is connected to the vehicle

Do not operate the shift lever. In the unlikely event that the AC charging cable has been damaged, the shift position may change from P to another position and the vehicle could move, possibly leading to an accident.

Charging precautions

This vehicle has been designed to allow charging from an external power source using a AC charging cable for exclusive use with standard household AC sockets.

However, the vehicle differs greatly from standard household electrical goods in the following ways, and incorrect usage could cause fire or electric shock, possibly leading to death or serious injury.

- The charging operation is designed to operate at 8A-10A continuously for the charge duration (approximately 9 hours). (→P.120)
- Charging can be conducted outdoors.

To charge properly, follow the procedure after reading the explanation below. Charging is intended to be carried out by licensed drivers only who properly understand the charging procedure.

- Do not allow children to use the AC charging cable without supervision. Also, keep the AC charging cable out of reach of

infants.

- When charging with a charger, follow the procedures for using each charger.
- When charging using a public charging facility, check the setting of the charging schedule function.
- When the charging schedule is registered, temporarily turn off the function or turn “Charge Now” on. (→P.137)
- When the charging schedule is set to on, charging will not start even if the AC charging cable is connected. Also, charging fee may occur due to connection of the AC charging cable.

Confirm the following before charging

Before charging, always check the following items.

- The parking brake is applied. (→P.288)
- Lights such as the headlights, emergency flashers and interior lights etc. are turned off.

If these light switches are turned on, then these features will consume electricity, and charging time will increase.

- The power switch is turned to OFF. (→P.282)

Inspecting the AC charging cable

Before charging, make sure that each part of the AC charging cable is in good condition. (→P.110)

During charging

- The charging starting time may differ depending on the state of the vehicle, but this does not indicate a malfunction.
- Cooling fan sounds may be heard from near the rear seat. (→P.92)
- During charging, sounds may be heard from near the hybrid battery (traction battery) in accordance with the operation of the air conditioning system or “Battery Cooler” (→P.121).
- During and after charging, the rear seat and its surrounding area in which the onboard traction battery charger is installed may get warm.
- The surface of the CCID (Charging Circuit Interrupting Device) may become hot, but this does not indicate a malfunction. (When using Mode 2 AC charging cable.)
- Depending on radio wave conditions, interference may be heard on the radio.
- The current charging condition and the estimated time until charging will complete can be checked on the multi-information display.

Capacity reduction of the hybrid battery (traction battery)

The capacity of the hybrid battery (traction battery) will decline gradually when the hybrid battery (traction battery) is in use. The rate at which it declines will differ in accordance with environmental conditions and the way in which the vehicle is used. Observing the following can help suppress battery capacity decline.

- Avoid parking the vehicle in areas with a high temperature under direct sunlight when the hybrid battery (traction battery) is fully charged.
- Avoid accelerating and decelerating frequently and suddenly when EV driving.
- Avoid frequent driving near the top

speed for EV driving. (→P.84)

- Leave a low level of charge in the hybrid battery (traction battery) when leaving the vehicle undriven for a long period of time.
After confirming that EV mode or AUTO EV/HV mode has switched to HV mode, turn the power switch off.
- Use the charging schedule function as much as possible in order to fully charge the hybrid battery (traction battery) immediately before starting off. (→P.136)

Also, if the hybrid battery (traction battery) capacity reduces, the distance that can be driven in EV mode or AUTO EV/HV mode decreases. However, vehicle performance does not significantly become worse.

■ **When the remaining charge of the hybrid battery (traction battery) is low after charging**

In the following situations, the remaining charge of the hybrid battery (traction battery) after charging completes may be less than normal in order to protect the system (the EV driving range after the battery is fully charged may be shorter).*

- Charging is carried out when the outside temperature is low or high.
- Charging is carried out immediately after high-load driving or in extreme heat.

When none of the above situations apply and there is a drastic drop in the remaining charge of the hybrid battery (traction battery) after charging completes, have the vehicle inspected by a SUZUKI dealer or a qualified workshop.

*: When this occurs, even if the remaining charge display of the hybrid battery (traction battery) shows that it is fully charged, the remaining charge rapidly decreases faster than normal.

■ **When the charging amount sent to the hybrid battery (traction battery) decreases**

When the amount of power supplied by the charger is low or operation of the “Battery Heater”, etc., reduces the charging power sent to the hybrid battery (traction battery), the charging amount sent to the hybrid battery (traction battery) may decrease.

How to charge

This section explains the procedure for charging the hybrid battery (traction battery) with the equipped AC charging cable.

When using a charging station, make sure to check the operation instructions on the charging station.

When the charging schedule is registered, make sure “Charge Now” is turned on before charging. (→P.142)



WARNING

■ AC charging inlet

Do not disassemble, repair or modify the AC charging inlet. Doing so may lead to unforeseen accidents or serious injury. When the AC charging inlet needs to be repaired, consult a SUZUKI dealer or a qualified workshop.



NOTICE

■ When using the AC charging cable and related parts

To prevent damage to the AC charging cable and related parts, observe the following precautions.

- When interrupting or canceling charging, remove the charging connector before removing the plug.
- When removing the AC charging cable, check that the charging connector is unlocked.
- Do not forcefully pull the charging connector cap and AC charging inlet cap.

- Do not apply a vibration to the charging connector while charging. Charging may be stopped.
- Do not insert anything but the charging connector into the AC charging inlet.
- When inserting the plug into or removing the plug from the socket, make sure to hold the body of the plug.
- Do not damage the AC charging inlet cap with a sharp object.
- Do not forcefully pull the AC charging cable that is caught or entangled. If the cable is entangled, disentangle it before using.

Charging precautions

→P.126

When charging

- 1 Prepare the AC charging cable.
 - ▶ When using the Mode 2 AC charging cable
- 2 Make sure to hold the body of the plug and insert it firmly into the socket.

If you have a remote switch, turn it on. Check that the power indicator on the CCID (Charging Circuit Interrupting Device) is illuminated. (If it is not illuminated, refer to P.148)

Use a string, etc. to hang the CCID (Charging Circuit Interrupting Device) on a hook or equivalent when a load is applied to the socket and plug due to the installation height of the socket.

The CCID (Charging Circuit Interrupting Device) can be hung by using the hole in the back. Do not attach the CCID (Charging Circuit Interrupting Device) to the wall with screws.

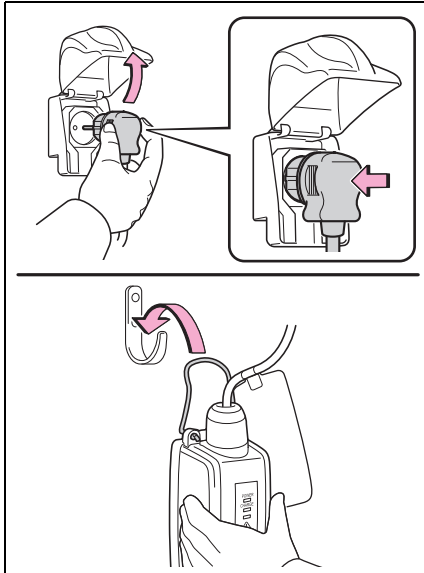

- ▶ When using the Mode 3 AC charging cable (if equipped)
- 2** Remove the cap of the charging plug and then connect the charging plug to the charger.

When connecting the charging plug into the charger, make sure that the identification symbols are the same.

Make sure to hold the body of the charging plug and insert it firmly and fully into the charger.

Follow the instructions of the charger for details regarding how to connect the AC charging cable and how to start charging. Depending on the charger, it may be necessary to receive authorization to use it. For details, refer to the information of the charger.

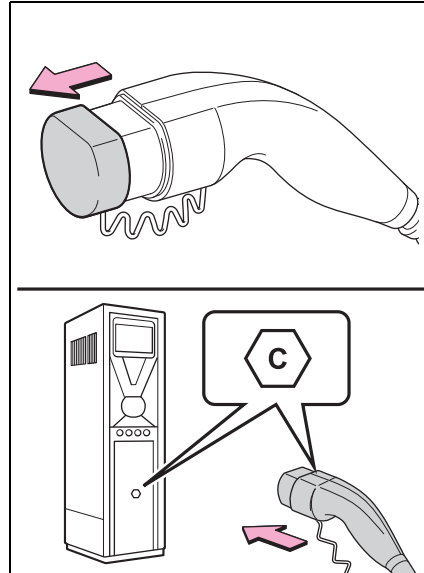

- 3** Unlock the doors and open the charging port lid. (→P.114)

The AC charging inlet light (A) will illuminate.

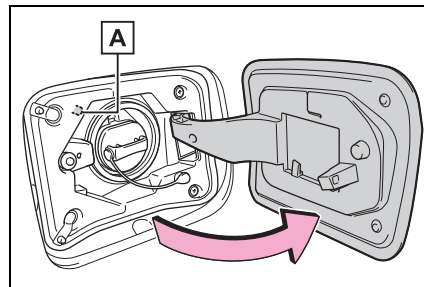

- 4 Remove the AC charging inlet cap and secure it into the holder on the charging port lid.

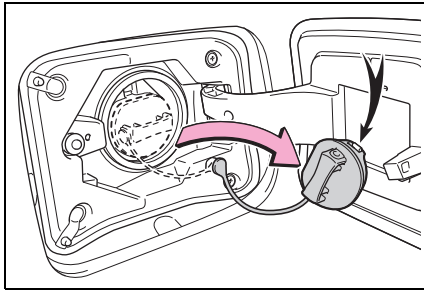

- 5 Remove the charging connector cap and secure it to the cable.

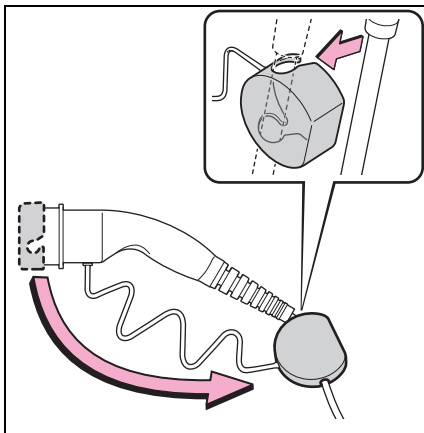

- 6 Make sure to hold the body of the charging connector and insert it firmly and fully into the AC charging inlet.

When connecting the charging connector into the AC charging inlet, make sure that the identification symbols are the same.

When the charging connector is inserted straight as far as possible, it will automatically lock. Check that the charging indicator illuminates. If the charging indicator does not illuminate,

the charging connector is not locked.*

*: If the charging connector is not firmly inserted, locking operation will be performed several times.

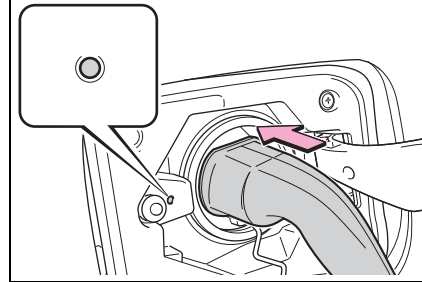
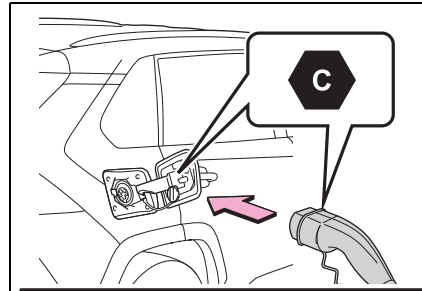

- 7 If the charging indicator of the charging port flashes after inserting the charging connector:

The charging schedule is registered (→P.136).

After temporarily removing the charging connector, reinsert it within approximately 5 seconds. (→P.131)

If the error warning indicator on the CCID (Charging Circuit Interrupting Device) flashes during charging, check P.107 and follow the correction procedure.

The charging indicator will turn off when charging is completed.

The charging indicator will also turn off when charging is stopped for some reason before completion. In this case, refer to P.148.

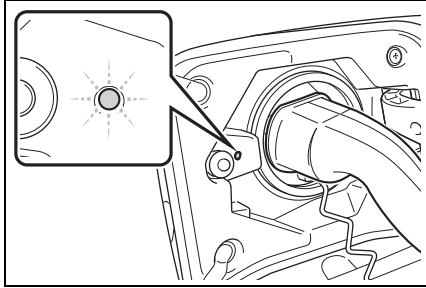

■ **If the charging indicator of the charging port flashes after connecting the AC charging cable**

The charging schedule (→P.136) is registered and charging cannot be performed. To cancel charging using the charging schedule and start charging, perform any of the following procedures.

- Turn “Charge Now” on (→P.142)
- While the charging indicator is flashing, remove and reconnect the charging connector within 5 seconds

■ **When the charging connector cannot be inserted into the AC charging inlet**

→P.115

■ **Charging time**

→P.120

■ **Safety function**

Charging will not start when the charging connector is not locked. If the charging indicator does not illuminate even when the charging connector is inserted, remove and reinsert the connector, and then check that the charging indicator of the charging port illuminates.

■ **Charging time may increase**

→P.121

■ **While charging**

When the power switch is turned to ON and the energy monitor is displayed on the audio system screen, the charging connector is displayed on the energy monitor and the flow of electricity during charging is displayed (→P.182).

■ **Charging at a public charging station with authentication function**

When a door is unlocked during charging, the charging connector is unlocked and charging will be stopped. In this case, the charging station authentication is canceled and charging may not be able to restart. Reconnect the charging connector and perform authentication for the charging station.

WARNING

■ **When charging**

Observe the following precautions.

Failure to do so may cause an unexpected accident, resulting in death or serious injury.

- Connect to a power source suitable for charging. (→P.117)
- Check that the AC charging cable, plug and socket are free of foreign matter.
- Before charging, check that the AC charging inlet is not deformed, damaged or corroded, and check that the inlet is free of foreign matter such as dirt, snow and ice. If there is dirt or dust in these areas, remove completely before inserting the charging connector.
- Before inserting the charging plug into the charger, make sure there is no dirt or dust on the terminal areas. If there is dirt or dust in these areas, remove completely before inserting the charging plug.
- Do not get the terminals of the AC charging inlet wet.
- Only use sockets where the plug can be securely inserted.
- Do not bundle or wind the AC charging cable while charging, as doing so may result in overheating.

**WARNING**

- Do not touch the terminals of the charging connector and AC charging inlet with a sharp metal objects (needles etc.) or hands, or short them with foreign objects.
- When charging outdoors, make sure to connect to a rain-tight socket for outdoor use. Ensure the rain-tight cover closes completely. If the rain-tight cover cannot be closed, install a rain-tight cover that will close.
- In order to stop charging at the charging station, follow the instructions of the charger.
- If any heat, smoke, odors, noise or other abnormalities are noticed during charging, stop charging immediately.
- Do not insert the plug if the socket is submerged in water or snow.
- When charging while it is raining or snowing, do not connect or disconnect the plug if your hands are wet. Also, do not get the plug or outlet wet.
- Do not charge the vehicle during a lightning storm.
- Prevent the AC charging cable from being caught in the door or back door.
- Do not let the wheels on the AC charging cable, plug, charging connector and CCID (Charging Circuit Interrupting Device).
- Firmly insert the plug into the socket.
- Do not use an extension cord and converting adaptor.

- Close the hood before using the charging system.
The cooling fan may start operating suddenly. Touching or getting close to rotating parts such as the fan may cause your hands or clothes (especially a necktie or scarf) to become caught and result in a serious injury.
- After connecting the charging cable, confirm that it is not wound around anything.
- If the power indicator on the CCID (Charging Circuit Interrupting Device) does not illuminate after plugging the AC charging cable into the socket-outlet, unplug it immediately.

■ **If the error warning indicator on the CCID (Charging Circuit Interrupting Device) illuminates or flashes during charging**

There may be an electrical leakage in the power source path, or there may be a malfunction in the AC charging cable or CCID (Charging Circuit Interrupting Device). Refer to P.106 and follow the correction procedure. If the error warning indicator does not turn off even after performing the correction procedure, immediately stop charging, remove the AC charging cable and contact a SUZUKI dealer or a qualified workshop. Continuing to charge the vehicle in that condition may lead to unforeseen accidents or serious injury.

⚠ WARNING**■ Onboard traction battery charger**

The onboard traction battery charger is located under the rear seats. Make sure to observe the following precautions regarding the onboard traction battery charger. Failure to observe these precautions may result in death or serious injury such as burns and electric shocks.

- The onboard traction battery charger is hot during charging. Do not touch the onboard traction battery charger, as doing so may result in burns.
- Do not disassemble, repair or modify the onboard traction battery charger. When the onboard traction battery charger needs to be repaired, consult a SUZUKI dealer or a qualified workshop.

⚠ NOTICE**■ When charging**

Do not insert the plug into the AC charging inlet.

The AC charging inlet may be damaged.

■ Using private power generator

Do not use private power generators as a power source for charging.

Doing so may make charging unstable, the voltage may be insufficient, and the error warning indicator on the CCID (Charging Circuit Interrupting Device) of the AC charging cable may flash.

■ Charging station

Due to the environment in which the power equipment is located, charging may be unstable due to noise, the voltage may be insufficient, and the error warning indicator on the CCID (Charging Circuit Interrupting Device) of the AC charging cable may flash.

■ Onboard traction battery charger cooling air intake vent

Cooling air intake vent for the onboard traction battery charger is installed under the rear seats. Make sure to observe the following precautions regarding the cooling air intake vent. Failure to observe these precautions may result in a charging system malfunction.

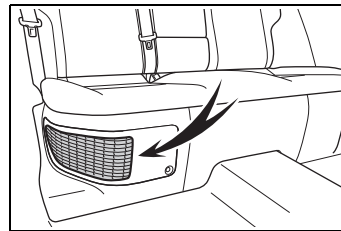

- Do not block the air intake vent with seat covers or luggage
- If the air intake vent is clogged with dust, clean it with a vacuum cleaner
- Do not allow water or foreign matter to enter the air intake vent
- Do not spill large amounts of water near the air intake vent
If water is spilled, have the vehicle inspected by a SUZUKI dealer or a qualified workshop and do not charge the hybrid battery (traction battery) before the inspection.

After charging

To prevent electrical shock, be sure to remove by following the procedures below.

- 1 Unlock the doors to unlock the charging connector. (→P.115)

The charging connector will be unlocked and the AC charging inlet light will illuminate when the doors are unlocked.

If the charging connector is unlocked

during charging (while the charging indicator is on), charging will be interrupted.

- 2** Make sure to hold the body of the charging connector and pull it towards you.

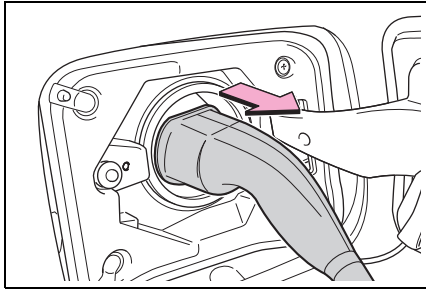

- 3** Attach the charging connector cap.

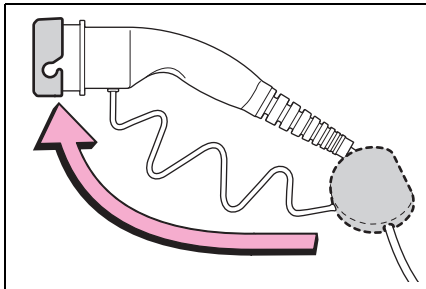

- 4** Attach the AC charging inlet cap and close the charging port lid.

Lock the doors to lock the charging port lid. (→P.114)

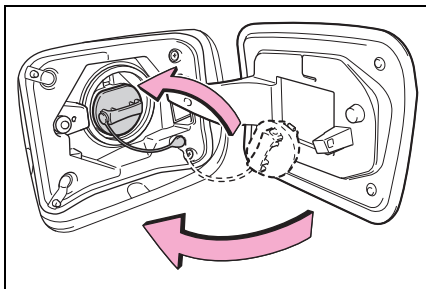

- ▶ When using the Mode 2 AC charging cable

- 5** Remove the plug from the socket when the charging equipment will not be used for a prolonged period of time.

Hold the body of the plug when removing.

Make sure to put the cable away immediately after disconnecting. (→P.135)

When leaving the plug inserted, inspect the plug and connector once a month to check if dirt or dust has accumulated.

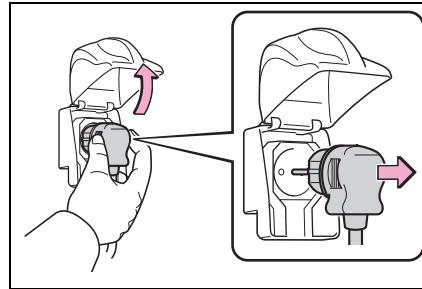

- ▶ When using the Mode 3 AC charging cable (if equipped)

- 5** After removing the charging plug from the charging device, install the cap to the charging plug.

Make sure to hold the body of the charging plug when removing it.

Make sure to put the cable away immediately after disconnecting. (→P.135)

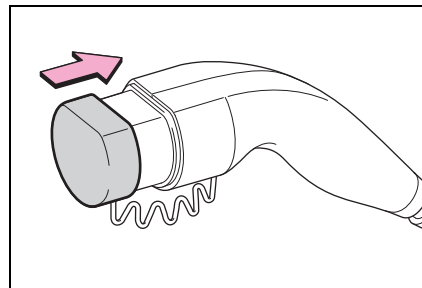

■ When the outside temperature is low or high

The level shown on the SOC (State of Charge) gauge (→P.166) may drop slightly when the power switch is turned to ON, even if charging has been completed and the hybrid battery (traction battery) is fully charged. However, this does not indicate a malfunction.

■ When removing the charging connector

Unlock the doors using the smart entry & start system or wireless remote control to unlock the charging connector, check that the lock is released, and then pull the charging connector towards you. (→P.114)

■ If the charging connector cannot be unlocked

→P.116

- After removing the plug from the socket, keep it in a safe place free from moisture and dust. The AC charging cable or plug may be damaged if the cable is stepped on or ridden over by the vehicle.



WARNING

■ After charging

Remove the plug if it will not be used for a long time.

Dirt and dust may accumulate plug or socket, which could cause a malfunction or fire, possibly leading to death or serious injury.



NOTICE

■ After charging

- Store the AC charging cable out of reach from infants and children.
- After disconnecting the charging connector from the AC charging inlet, make sure to put on the AC charging inlet cap and close the charging port lid. If the AC charging inlet cap is not put on, water or foreign objects may enter the AC charging inlet, which could lead to vehicle damage.

Using the charging schedule function

Charging can be carried out at the desired time by registering the charging schedule. Also, it is possible to set the charging schedule to one's preferences, such as having charging complete by a certain departure time or be carried out at the same time on certain days.

■ Calendar settings

Current date and time information is automatically set using GPS. However, if GPS calibration of clock is turned off in the multimedia system settings, the date needs to be set on the multi-information display.

If the calendar settings check screen is displayed when an attempt was made to register a charge schedule, check that the correct date is set. If it is incorrect, be sure to correct it.

If the calendar information is wrong, the charging schedule function will not operate normally.

Settings of the charging schedule function

When registering the charging schedule, the following settings can be changed.

■ Select the charging mode

One of the two following charging modes can be selected.

▶ "Start"

Starts charging at the set time^{*1}

and finishes charging when fully charged.^{*2}

▶ "Departure"

Starts charging to finish at the set time.^{*3, 4}

When this setting is selected, the air conditioning-linked function can be used.

^{*1}: Charging schedule function is performed in accordance with the clock in the multi-information display. Before registering the charging schedule, check the clock settings to the proper time.

^{*2}: There might be a slight error in the timing when charging starts due to the state of the hybrid battery (traction battery).

^{*3}: When the system determines that there is no time to finish charging by the set scheduled departure time, it starts charging. Check the charging schedule.

^{*4}: If sudden changes in temperature or changes in the condition of the power source occur while charging, charging may not end exactly at the time estimated by the system.

■ Repeated setting

The periodic charging schedule can be set by selecting your desired day of the week. (If no days are selected, charging is only carried out once.)

■ Air conditioning-linked setting ("Climate Prep")

When the charging mode is set to "Departure", the vehicle air condi-

tioning system (→P.406) can be set to automatically operate* according to the set time.

By adjusting the cabin temperature in advance, passengers can enjoy a pleasant interior immediately after entering the vehicle.

*: Operation starts approximately 20 minutes before the set departure time.

■ Turning “Charge Now” on and off

If even one charging schedule is registered, charging does not start until the set time, even if the AC charging cable is connected to the vehicle. To start charging without changing the charging schedule setting, turn “Charge Now” on to temporarily cancel the charging schedule and enable charging after connecting the AC charging cable.*

*: If the charging connector is removed during charging while the charging schedule is registered and “Charge Now” is on, “Charge Now” turns off.

■ Changing “Next Event”^{*1}

It is possible to temporarily set the time of the next charging schedule without changing the registered repeated setting.^{*2}

^{*1}: The “Next Event” refers to the closest charging schedule from the current time among the registered charging schedules. Charging schedule is performed based on the “Next Event”.

^{*2}: When “Next Event” is changed, the

current charging schedule will be temporarily ignored and charging will not be carried out until the time specified by “Next Event”. (For example, when “Next Event” is set for 2 days later, even if items are registered on the charging schedule, charging will not be carried out until the time specified by “Next Event”.)

Registering the charging schedule

The charging schedule can be registered on the multi-information display: →P.139

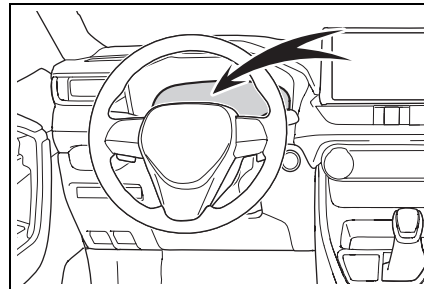

■ Timer settings

- The charging schedule cannot be set while driving.
- A maximum of 15 charging schedules can be registered.

■ To make sure that the charging schedule function operates correctly

Check the following items.

- Adjust the clock to the correct time (→P.171)
- The calendar is set to the correct date (→P.177)
- Check that the power switch is turned off
- After registering the charging schedule, connect the AC charging cable

The charging start time is determined based on the charging schedule at the time that the AC charging cable was connected.

- After connecting the AC charging cable, check that the charging indicator of the charging port flashes (→P.101)
- Do not use an socket that has a power cut off function (including a timer function)
Use an socket that constantly supplies electricity. For sockets where the power is cut off due to a timer function, etc., charging may not be carried out according to plan if the power is cut off during the set time.

■ When the AC charging cable remains connected to the vehicle

Even if multiple consecutive charging schedules are registered, the next charge will not be carried out according to the charging schedule until the AC charging cable is removed and reconnected after charging completes. Also, when the hybrid battery (traction battery) is fully charged, charging according to the charging schedule will not be carried out.

■ “Climate Prep”

- When the air conditioning-linked setting is turned on, the air conditioning operates until the set departure time. Therefore, the air conditioning will consume electricity and charging may not complete by the set departure time.
- If the hybrid battery (traction battery) is fully charged, charging will not be carried out, even if the charging schedule is set. However, if “Climate Prep” is turned on, the air conditioning will operate only once when it nears the time set in “Departure”. If this occurs, the air conditioning will consume electricity and the remaining charge of the hybrid battery (traction battery) when departing may be decreased.

- When the doors are unlocked, the air conditioning system does not operate.

■ When charging schedules are ignored

When the following operations are performed while the charging schedule is on standby, charging schedule is temporarily canceled and charging is started.

- When the Remote Air Conditioning System (→P.413) is operated
- When turning “My Room Mode” on (→P.145)
- When turning “Charge Now” on (→P.142)
- When an operation that temporarily cancel charging using the charging schedule (→P.131)

■ Effects of outside temperature

When the charging mode is set to “Departure”, charging schedule may be ignored due to the outside temperature and charging may start.

■ “Battery Heater” (→P.121)/“Battery Cooler” (→P.121)

When charging is carried out using the charging schedule, the hybrid battery (traction battery) heating or cooling function may operate according to the temperature of the hybrid battery (traction battery).

- When the charging mode is set to “Start”, the function starts at the set charging start time.
- “Battery Heater”: When the charging mode is set to “Departure”, the function starts automatically to complete heating by the desired departure time.
- “Battery Cooler”: When the charging mode is set to “Departure”, cooling starts approximately 30 minutes before the charging start time. However, if there is no time to finish charging by the charging schedule, the hybrid battery (traction battery) cooling time may be shortened and “Battery Cooler” may not operate.

Setting procedure

When operating charging schedule, use the meter control switches.

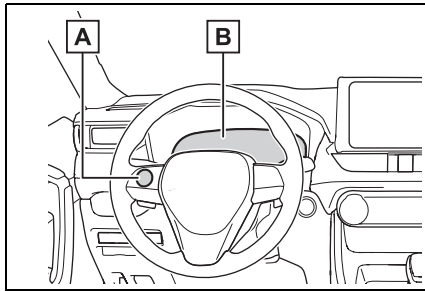

A Meter control switches (→P.172)

B Multi-information display

■ Registering the charging schedule

- 1 Press **<** or **>** of the meter control switches to select .
- 2 Press **^** or **v** of the meter control switches to select "Vehicle Settings", and then press and hold **OK**.
- 3 Press **^** or **v** of the meter control switches to select "Charging Settings", and then press **OK**.
- 4 Press **^** or **v** of the meter control switches to select "Charging Schedule", and then press **OK**.

The "Charging Schedule" screen will be displayed.

- 5 Press **^** or **v** of the meter control switches to select "Scheduled Events", and then press **OK**.

The "Scheduled Events" screen will be displayed.

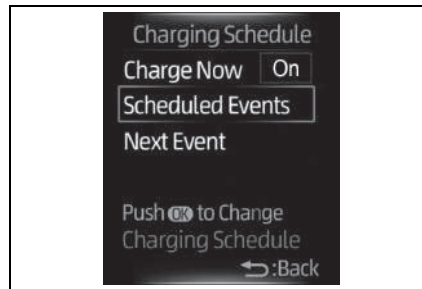

- 6 Press **^** or **v** of the meter control switches to select "+", and then press **OK**.

The "Charging Mode" screen will be displayed.

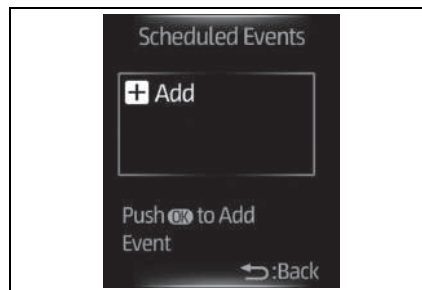

- 7 Press **<** or **>** of the meter control switches to select the item to change with the cursor, and then press **^** or **v** to change the setting.

Set the desired charging mode and charging start (or departure) time.

When the charging mode is "Start", this sets the charging start time. When it is "Departure", this sets the charging end



time.

After changing the settings to the desired settings, press .

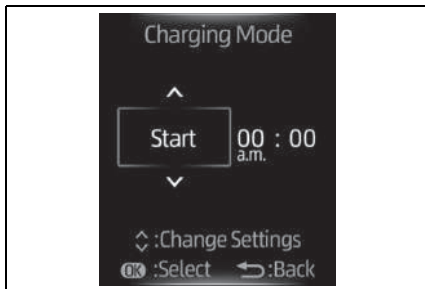
When the charging mode is set to "Departure", the "Climate Prep" screen is displayed. When the charging mode is set to "Start", the "Repeat" screen (step 9) is displayed.





- 8 When the charging mode is set to "Departure", set the "Climate Prep" to on or off.*

Press  or  of the meter control switches and select "Yes" or "No", and then press .

Select "Yes" to turn on the air conditioning system and select "No" to turn it off. The "Repeat" screen will be displayed.

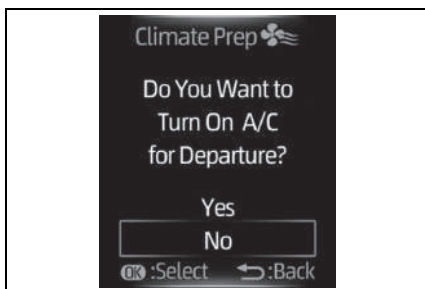
*: When the charging mode is set to "Start", "Climate Prep" screen will not display.



- 9 To activate the repeated setting, press  or  of the meter

control switches to select the desired day to activate for the repeated setting, and then press



Each time  is pressed, the repeated setting switches between on and off.

When set to on, the charging schedule is repeated on that day. It is possible to set more than one day to on.

If no days are set to on, charging is only carried out once according to the charging schedule for the next 24 hours.

After changing the settings to the desired settings, select "Done", and then press .

A screen where the settings can be saved will be displayed.

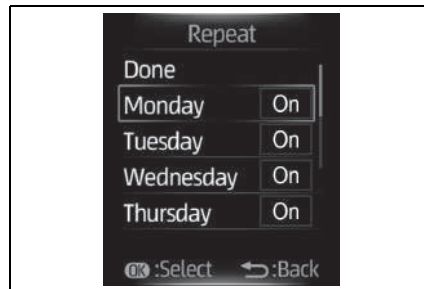

- 10 Select "Save" and press  to save the settings.

The settings will be saved.

If you wish to change the settings, press  and perform the setting procedure again.

After setting operations are complete, when the AC charging cable is connected to the vehicle, charging will be carried out according to the charging schedule settings.

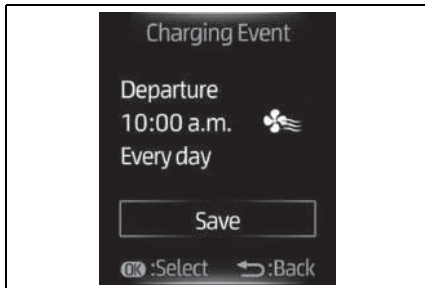

■ **Switching charging schedules between on and off**

The registered charging schedules can be turned on and off.

- 1 Perform step 1 to 5 of the “Registering the charging schedule” procedure (→P.139) and display “Scheduled Events” screen.

A list of the registered charging schedule will be displayed.

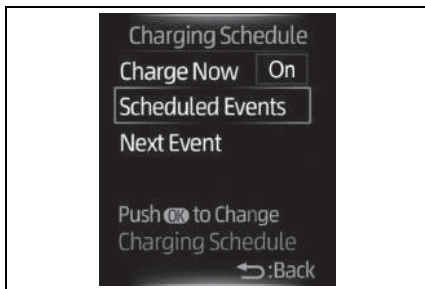

- 2 Press or of the meter control switches to select the item to turn ON/OFF, and then press .

Each time is pressed, the selected charging schedule switches between on and off.

When set to off, a charging schedule is ignored and charging according to the charging schedule is not carried out.

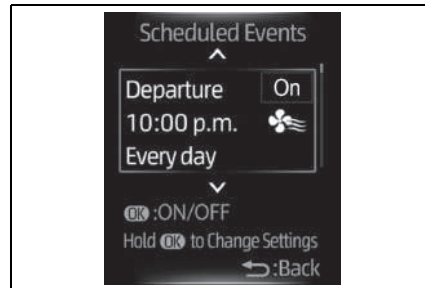

■ **Changing the registered charging schedules**

The registered charging schedules can be modified or deleted.

- 1 Perform step 1 to 5 of the “Registering the charging schedule” procedure (→P.139) and display “Scheduled Events” screen.

A list of the registered charging schedule will be displayed.

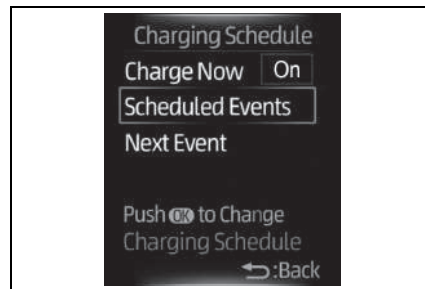

- 2 Press or of the meter control switches to select the item to change, and then press and hold .

The “Edit Event” screen will be displayed.

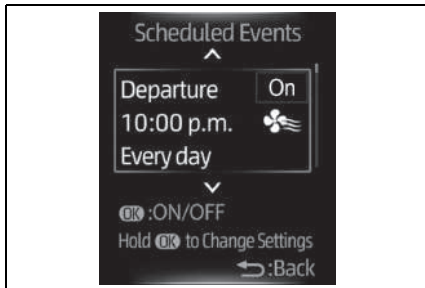

- 3 Press or of the meter control switches to select the item to operate, press and perform the necessary operation.



● “Edit”

Change the desired settings as described starting from step 7 of the “Registering the charging schedule” procedure. (→P.139)

Press to return to the previous screen.

● “Delete”

A deletion confirmation screen will be displayed.

Press or of the meter control switches to select “Yes”, and then press to delete the selected charging schedule.

To cancel deletion, select “No” and then

press .

Press to return to the previous screen.

■ Setting “Charge Now” to on

The “Charge Now” setting can be changed by performing one of the two following procedures.

▶ Operation on “Charging Schedule” screen

- 1 Perform step 1 to 4 of the “Registering the charging schedule” procedure (→P.139) and display “Charging Schedule” screen.

- 2 Press or of the meter control switches to select “Charge Now”, and then press



Each time is pressed, “Charge Now” switches between on and off.

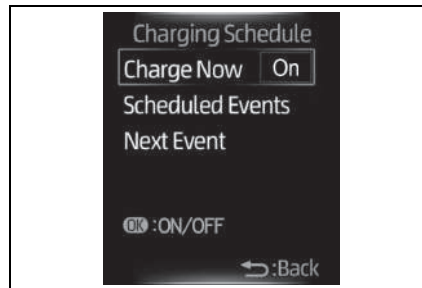

▶ Operation on “Closing Display” screen*

*: If “Closing Display” is not set to “Charging Schedule” on the screen of the multi-information display, the “Closing Display” is not displayed. In this case, check the settings on the multi-information display.

play.

- 1 Turn the power switch off.

The “Closing Display” screen is displayed on the multi-information display. (→P.144)

- 2 Press to set “Charge Now” to on.

Each time is pressed, “Charge Now” switches between on and off.

After setting operations are complete, charging starts when the AC charging cable is connected. (→P.128)

■ **Changing “Next Event”***

*: When “Charge Now” is set to on or when using “My Room Mode” (→P.145) etc., it is not possible to change the registered “Next Event”.

- 1 Perform step 1 to 4 of the “Registering the charging schedule” procedure (→P.139) and display “Charging Schedule” screen.

- 2 Press or of the meter control switches to select “Next Event”, and then press .

The “Next Event” screen will be displayed.

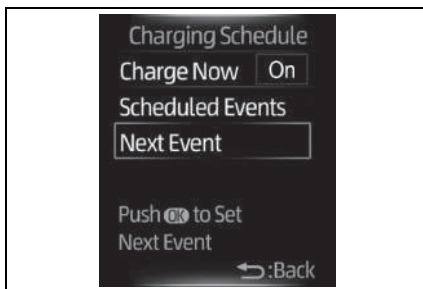

- 3 Press or of the meter control switches to select “Yes”, and then press .

The confirmation message will be displayed on the screen.

Press , and the “Charging Mode” screen will be displayed.

Press to return to the previous screen.

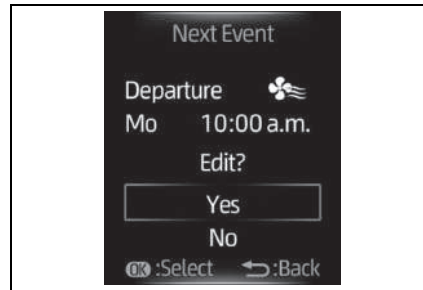

- 4 Change the desired settings as described starting from step 7 of the “Registering the charging schedule” procedure. (→P.139)

Press to return to the previous screen.

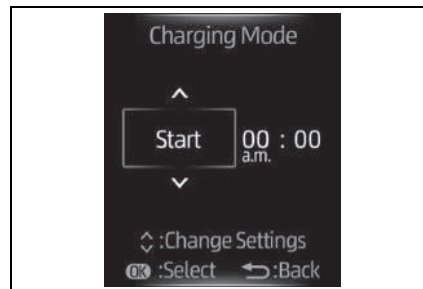

■ **When charging schedule setting operations are canceled**

When the vehicle is in the following conditions, charging schedule setting operations are canceled.

- The power switch is operated before

2
Plug-in hybrid system

the settings are confirmed

- The vehicle starts off
- A display with a higher priority than that of the charging schedule setting is shown

■ **“Next Event”**

After charging completes, the “Next Event” displayed on the multi-information display will not change until the AC charging cable is removed, even after charging is performed according to the “Next Event” schedule.

■ **To return to original setting after changing “Next Event” setting**

Turning the setting of “Charge Now” on and then off can return the setting of “Next Event” to its original setting.

■ **When “Next Event” is changed while charging**

- When the charging mode is “Departure”, the current charging is interrupted or continued depending on the remaining time until the charging is completed.
- When the charging mode is “Start”, the current charging is interrupted, the next charging will start at the set time.

■ **When the power switch is turned off**

You can check the next charging schedule (“Next Event”) on the “Closing Display” screen* when “Closing Display” is set to “Charging Schedule” on  screen of the multi-information display and the power switch is turned off.

*: The “Closing Display” screen may not be displayed during charging.

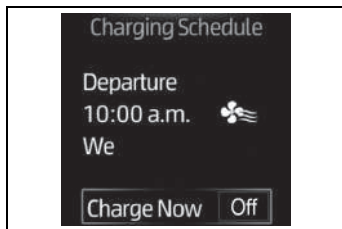

 **WARNING**

■ **Cautions while performing the setting operation**

When performing the setting operation while the hybrid system is operated, ensure that the vehicle is parked in a place with adequate ventilation. In a closed area such as a garage, exhaust gases including harmful carbon monoxide (CO) may collect and enter the vehicle. This may lead to death or a serious health hazard.

 **NOTICE**

■ **While performing the setting operation**

When performing the setting operation while the hybrid system is stopped, be careful that the 12-volt battery will not be discharged.



Using the “My Room Mode”

When the AC charging cable is connected to the vehicle, electrical components such as the air conditioning system or audio system can be used using the external power source.

Starting “My Room Mode”

- 1 Connect the AC charging cable to the vehicle and start charging
- 2 Turn the power switch on during charging

The setting screen of “My Room Mode” is displayed automatically on the multi-information display.

- 3 Press  or  of the meter control switches, select “Yes”, and then press .

“My Room Mode” starts and systems such as the air conditioning system and audio system can be used inside the vehicle.

When not using “My Room Mode”, select “No”, and then press .

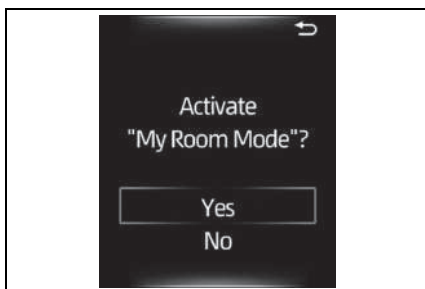

To stop “My Room Mode”, turn the

power switch off.

Display of power balance information while using “My Room Mode”

When “My Room Mode” starts, the remaining charge display screen for the hybrid battery (traction battery) is displayed automatically on the multi-information display. The approximate power balance (balance between electricity supply and consumption) while using “My Room Mode” can be checked from the color and size of the arrows.

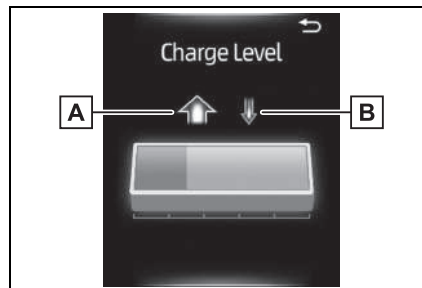

A Discharging status

B Charging status

When the electricity supply from the AC charging cable is larger than the power consumption inside the vehicle, **B** becomes larger. When the power consumption is larger than the electricity supply, **A** becomes larger.

When the electricity supply and consumption are balanced (when the power balance is judged to be zero),

A and **B** are displayed as the same size.

2
Plug-in hybrid system

■ When a door is unlocked while using “My Room Mode”

The charging connector unlocks, charging stops and “My Room Mode” stops. In order to use “My Room Mode” again, reconnect the AC charging cable and start “My Room Mode” (→P.145). When using “My Room Mode” with public charging station, operation to start charging using the charger may be required again before starting “My Room Mode”.

■ Meter display during charging

If “My Room Mode” is not turned on for approximately 100 seconds after the power switch is turned on during charging, the power switch will automatically turn off.

■ While using “My Room Mode”

Any of the following may occur.

- When the remaining charge of the hybrid battery (traction battery) reaches the lower limit, the air conditioning system automatically turns off. In this situation, the air conditioning system cannot be used until the remaining charge of the hybrid battery (traction battery) increases. Turn the power switch off and use “My Room Mode” after the remaining charge of the hybrid battery (traction battery) is restored.
- When the outside temperature is low, the heater output may be limited due to the air conditioning system operation being restricted.
- Warning lights and indicators such as electric power steering system warning light (yellow) and malfunction indicator lamp may turn on, but this is not a malfunction. Also, when the surrounding area is dark, the headlights are turned on. (→P.294)

■ When a charging schedule is registered

When “My Room Mode” starts while the charging schedule is on standby,

charging schedules are ignored and charging starts.

■ When “My Room Mode” is used while the hybrid battery (traction battery) is fully charged

When the power switch is turned on while the hybrid battery (traction battery) is fully charged and the charging connector that supplies power is connected, “Charging Port Lid is Open” is displayed on the multi-information display. In this

case, press  of the meter control switches to display the setting screen of “My Room Mode”, and then select “My Room Mode”.

When “My Room Mode” is used while the hybrid battery (traction battery) is fully charged, the electric power of the hybrid battery (traction battery) may be consumed. In this case, charging may be performed again.

■ When a message related to “My Room Mode” is displayed

When a message is displayed on the multi-information display while using or attempting to start “My Room Mode”, take the following correction procedures.

- “Traction battery is too low for “My Room Mode””

There is insufficient remaining charge in the hybrid battery (traction battery) for starting “My Room Mode”.

Wait until the charge of the hybrid battery (traction battery) increases, then start “My Room Mode”.

- ““My Room Mode” has stopped due to low traction battery”

The remaining charge in the hybrid battery (traction battery) is insufficient.

Stop using “My Room Mode” and charge the hybrid battery (traction battery).

- ““My Room Mode” will stop when traction battery is too low Reduce power usage to continue using “My Room Mode””

The power consumption inside the vehicle is greater than the power being charged to the hybrid battery (traction battery), and the remaining charge of the hybrid battery (traction battery) is low.*

- “My Room Mode” will end unless the power consumption inside the vehicle is improved.
- To continue using “My Room Mode”, turn off the power of systems such as the air conditioning system and audio system to increase the remaining charge of the hybrid battery (traction battery).

*: The power balance status during “My Room Mode” can be checked from the remaining charge display screen for the hybrid battery (traction battery) displayed on the multi-information display.

**WARNING****■ Cautions for using “My Room Mode”**

Make sure to observe the following precautions.

Failure to do so may result in serious health problems or even death.

- Do not leave children, people who need assistance, or pets inside the vehicle. The system may turn off automatically and the interior temperature may become high or low, resulting in heat stroke, dehydration or hypothermia. Devices such as the wipers can also be used, which may lead to mistaken operation and an accident.
- Check the safety around the vehicle carefully before use.

When charging cannot be carried out

When charging does not start, even though the normal procedure is followed, check each of the following items.

If a message is shown on the multi-information display, also refer to P.152.

When charging cannot be carried out

Refer to the following table and carry out the appropriate correction procedure.

- **The power source indicator on the CCID (Charging Circuit Interrupting Device) does not illuminate, even though the plug is connected to an external power source.**

Likely cause	Correction procedure
Plug is not properly connected to socket	Check that the plug is properly connected to the socket.
Power is out	After power is restored, carry out the charging procedure again.
Remote switch is off	If the remote switch is equipped, turn the switch on.
Building breaker is tripped and power is cut off	Check that the breaker is connected and if there is no malfunction, check if the vehicle can be charged through another socket. If charging is possible, the first socket may have a malfunction. Contact the building or facility manager, or an electrician.
Short circuit between CCID (Charging Circuit Interrupting Device) and plug	Immediately stop charging and contact a SUZUKI dealer or a qualified workshop.

■ The error warning indicator on the CCID (Charging Circuit Interrupting Device) flashes.

Likely cause	Correction procedure
Electrical leakage detection function or self-diagnostic function operates and power is cut off	When the voltage is insufficient, the error warning indicator may flash when there is noise interference. Perform a reset and connect to a proper power source. (→P.107) If charging does not start, immediately stop charging and contact a SUZUKI dealer or a qualified workshop.

■ Charging indicator of the charging port does not illuminate, even though charging connector is connected.

Likely cause	Correction procedure
The plug is not properly connected to the socket	Check whether the plug is properly connected to the socket.
Charging connector is not securely connected to AC charging inlet	Check the connection status of the charging connector. <ul style="list-style-type: none"> • When connecting the charging connector, insert the charging connector securely. • After connecting the charging connector, check that the charging indicator of the charging port is turned on. If the charging indicator of the charging port does not illuminate, even though the charging connector is securely connected, there may be a malfunction in the system. Immediately stop charging and contact a SUZUKI dealer or a qualified workshop.
Hybrid battery (traction battery) is already fully charged	When the hybrid battery (traction battery) is fully charged, charging is not performed.
The charger does not operate	Please contact the facility manager when there is a problem with charger.

■ **Charging indicator of the charging port flashes and charging cannot be carried out.**

Likely cause	Correction procedure
When charging indicator of the charging port flashes*: Charging schedule is registered	When you wish to charge according to the charging schedule, wait until the set time. To start charging, set "Charge Now" to on. (→P.142)
When charging indicator of the charging port rapidly flashes*: Malfunction occurred in an external power source or the vehicle	Start the hybrid system and follow the instructions displayed by the message on the multi-information display. (→P.152)

*: Refer to P.101 for details regarding charging indicator of the charging port illumination and flashing.

When charging schedule function does not operate normally

Refer to the following table and carry out the appropriate correction procedure.

■ **Cannot charge at desired time**

Likely cause	Correction procedure
Vehicle clock is not properly adjusted	Check the clock settings and adjust it to the proper time. (→P.171)
The vehicle calendar is not set correctly.	Check the calendar setting and set it to the correct date. (→P.177)
AC charging cable is not connected to vehicle	Before using the charging schedule, connect the charging cable.
Incorrect charging mode selected	Check the charging mode setting. (→P.136) When the charging mode is "Start", charging starts at the set time, but when it is "Departure", charging is completed by the set time. (The charging start time is automatically controlled by the system.)

■ Charging starts, even though charging schedule is registered

Likely cause	Correction procedure
“Charge Now” is set to on	When charging according to the charging schedule, set “Charge Now” to off. (→P.142)
Charging schedule is set to off	Check that charging schedule is not set to off. (→P.141)
Charging mode is set to “Departure” and schedule departure time is close to current time	When the system determines that there is no time to finish charging by the set scheduled departure time, it starts charging. Check the charging schedule.
AC charging cable was removed and reinserted while charging indicator of the charging port was flashing	If the charging cable is removed and reinserted while the charging indicator is flashing, the charging schedule is canceled (→P.131). Temporarily remove the charging cable, and then reconnect it.
The Remote Air Conditioning System was operated	When the Remote Air Conditioning System is operated, the system will start charging, even if the charging schedule is registered. To carry out charging using the charging schedule, stop the Remote Air Conditioning System, and then reconnect the charging cable.
“Battery Heater” (→P.121) operated	When the charging mode is set to “Departure”, “Battery Heater” may operate before charging starts. Check the status of the charging indicator of the charging port. (→P.101)

■ Charging ends earlier than time set in “Departure”

Likely cause	Correction procedure
Charging end time does not match estimated end time due to condition of power source or outside temperature	If sudden changes in temperature or changes in the condition of the power source occur while charging, charging may end earlier than the time estimated by the system.

■ **Charging is not complete, even though it is time set in “Departure”**

Likely cause	Correction procedure
“Climate Prep” is set to on	When “Climate Prep” is set to on, the air conditioning operates until the set departure time. Therefore, charging may not complete by the set time due to charging conditions. To have the hybrid battery (traction battery) fully charged, allow charging to continue.
Charging end time does not match estimated end time due to condition of power source or outside temperature	If sudden changes in temperature or changes in the condition of the power source occur while charging, charging may not end exactly at the time estimated by the system.

■ **Charging does not start, even though it is time set in “Start”**

Likely cause	Correction procedure
AC charging cable was connected after set time	Connect the charging cable before the time set in “Start”.

When charging-related message is displayed

When a door is opened with the power switch off, after charging, a message is displayed in the multi-information display.

When this occurs, follow the instructions displayed on the screen.

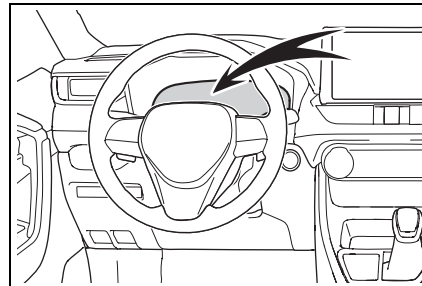

■ If “Charging Stopped Due to Pulled Charging Connector” is shown

Likely cause	Correction procedure
Charging connector is removed while charging	
After the hybrid battery (traction battery) is fully charged, the charging connector is removed while the hybrid battery (traction battery) is being recharged again because electricity-consuming functions* have been used and the remaining charge is now reduced.	When the charging connector is removed while charging, charging stops. If you want to fully charge the hybrid battery (traction battery), reconnect the charging connector.
Charging connector is not securely connected	<p>Check the connection status of the charging connector.</p> <ul style="list-style-type: none"> When connecting the charging connector, insert the charging connector securely. After connecting the charging connector, check that the charging indicator of the charging port is turned on. <p>If charging cannot be carried out, even though the proper procedures were followed, have the vehicle inspected by a SUZUKI dealer or a qualified workshop.</p>
Charging connector was unlocked while charging	When the charging connector is unlocked while charging, charging stops. To continue charging, reconnect the charging connector.

*: Electricity is consumed when operating “Battery Heater” (→P.121), the air conditioning-linked function (→P.136) or Remote Air Conditioning System (→P.413).

■ If “Charging Complete Limited Due to Battery Temp” is shown

Likely cause	Correction procedure
Charging was stopped to protect the hybrid battery (traction battery) as it continued to remain hot for a certain period of time.	Allow the hybrid battery (traction battery) to cool down and perform charging again if the charging amount has not reached the desired amount.

■ If “Charging Stopped Check Charging Source” is shown (1)

Likely cause	Correction procedure
<p>Problem in power supply from external power source</p>	<p>Check the following items.</p> <ul style="list-style-type: none"> • Plug is not disconnected • Remote switch is not off • Power source indicator on the CCID (Charging Circuit Interrupting Device) is illuminated • The circuit breaker has tripped <p>If there is no problem with any of the above items, there may be a problem with the socket of the building. Contact an electrician and request an inspection. (Contact the facility manager of the charging station when there is a problem with charging station.)</p> <p>If charging cannot be carried out, even though there is no problem with the power source path, there may be a malfunction in the system. Have the vehicle inspected by a SUZUKI dealer or a qualified workshop.</p> <p>Furthermore, if the error warning indicator on the CCID (Charging Circuit Interrupting Device) is flashing, there may be an electrical leakage. Consult a SUZUKI dealer or a qualified workshop.</p>

Likely cause	Correction procedure
Charger has stopped charging	<p>Charging may be canceled by an interruption of power supply depending on specifications of a charger. Refer to the instructions provided with the charger.</p> <ul style="list-style-type: none"> • When charging is stopped using the charger • Charger with charging schedule function • Charger that is not compatible with the charging schedule function of the vehicle <p>Check if it is possible to charge with the charging cable equipped to the vehicle.</p> <p>If charging cannot be carried out, even when using the genuine charging cable, consult a SUZUKI dealer or a qualified workshop.</p>

■ If “Charging Stopped Check Charging Source” is shown (2)

Likely cause	Correction procedure
Charger is not compatible with vehicle	Check if it is possible to charge with the charging cable equipped to the vehicle.
Charger has stopped charging	If charging cannot be carried out, even when using the genuine charging cable, consult a SUZUKI dealer or a qualified workshop.

■ If “Charging Stopped Check Charging Source” is shown (3)

Likely cause	Correction procedure
<p>Problem in power supply from external power source</p>	<p>Check the following items.</p> <ul style="list-style-type: none"> • Plug is securely inserted • Extension cord is not used and socket is not overloaded • Connected to a dedicated power line • Electrical leakage has occurred or not <p>If there is no problem with any of the above items, there may be a problem with the socket of the building. Contact an electrician to request an inspection.</p> <p>If charging cannot be carried out, even though there is no problem with the power source path, there may be a malfunction in the system. Have the vehicle inspected by a SUZUKI dealer or a qualified workshop.</p>
<p>Charger has stopped charging</p>	<p>Check if it is possible to charge with the charging cable equipped to the vehicle.</p> <p>If charging cannot be carried out, even when using the genuine charging cable, consult a SUZUKI dealer or a qualified workshop.</p>

■ If “Charging Stopped High Energy Use See Owner’s Manual” is shown

Likely cause	Correction procedure
<p>Power is being consumed by electrical components of vehicle</p>	<p>Check the following items, and then carry out charging again.</p> <ul style="list-style-type: none"> • If the headlights and audio are turned on, turn them off. • Turn the power switch off. <p>If charging cannot be carried out, even after performing the above, the auxiliary battery may not be sufficiently charged. Operate the hybrid system for approximately 15 minutes or more to charge the auxiliary battery.</p>

■ If “Charging System Malfunction See Owner’s Manual” is shown

Likely cause	Correction procedure
Malfunction occurred in charging system	Have the vehicle inspected by a SUZUKI dealer or a qualified workshop.

Vehicle status information and indicators

3

159

3-1. Instrument cluster

Warning lights and indicators	160
Gauges and meters	166
Multi-information display	171
Energy monitor/consumption screen	182

3

Vehicle status information and indicators



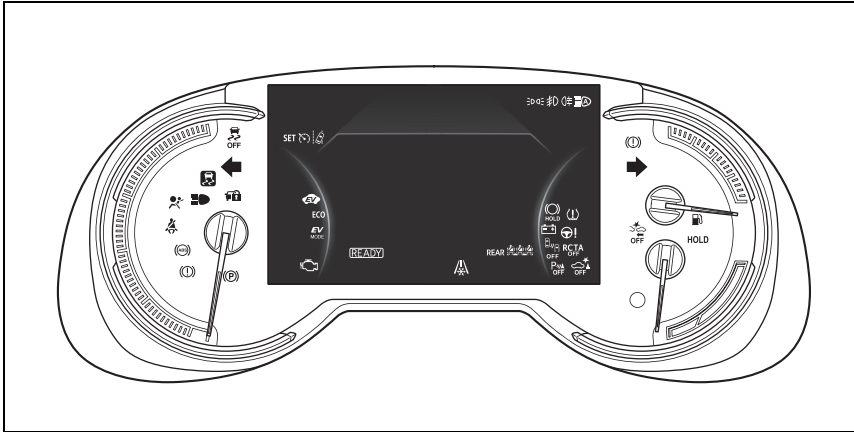









■ When digital speedometer is displayed













The units used on the meters and some indicators may differ depending on the target region.

Warning lights

Warning lights inform the driver of malfunctions in the indicated vehicle's systems.

-  Brake system warning light*¹ (→P.508)
(Red)
-  Brake system warning light*¹ (→P.508)
(Yellow)
-  Charging system warning light*¹ (→P.508)
-  High coolant temperature warning light*² (→P.509)
-  Hybrid system overheat warning light*² (→P.509)
-  Low engine oil pressure warning light*² (→P.509)
-  Malfunction indicator lamp*¹ (→P.509)
-  SRS warning light*¹ (→P.510)
-  ABS warning light*¹ (→P.510)
-  Electric power steering system warning light*¹ (→P.510)
(Red/yellow)
-  PCS warning light*¹ (→P.511)
(Flashes or illuminates)
-  LTA indicator (→P.511)
(Orange)
-  Parking assist-sensor OFF indicator*³ (→P.512)

-  PKSB OFF indicator*¹ (→P.512)
-  BSM OFF indicator*¹ (if equipped) (→P.513)
-  RCTA OFF indicator*¹ (→P.513)
-  Slip indicator light*¹ (→P.513)
Brake Override System/Drive-Start Control/PKSB warning light*² (→P.514)
-  Brake hold operated indicator*¹ (→P.514)
(Flashes)
-  Parking brake indicator (→P.514)
(Flashes)
-  Tire pressure warning light*¹ (→P.515)
-  Low fuel level warning light (→P.515)
-  Driver's and front passenger's seat belt reminder light (→P.515)
-  Rear passengers' seat belt reminder lights (→P.516)

*¹: These lights turn on when the power switch is turned to ON to indicate that a system check is being performed. They will turn off after the hybrid system is on, or after a few seconds. There may be a malfunction in a system if the light does not come on, or turn off. Have the vehicle inspected by a SUZUKI dealer or a qualified workshop.

*²: This light illuminates on the multi-information display with a message.

*3: Parking assist-sensor OFF indicator turns on when the power switch is turned to ON while the parking assist-sensor function is on. It will turn off after a few seconds.















WARNING

■ If a safety system warning light does not come on





















Should a safety system light such as the ABS and SRS warning light not come on when you start the hybrid system, this could mean that these systems are not available to help protect you in an accident, which could result in death or serious injury. Have the vehicle inspected by a SUZUKI dealer or a qualified workshop immediately if this occurs.

Indicators

The indicators inform the driver of the operating state of the vehicle's various systems.

-  Turn signal indicator (→P.287)
-  Tail light indicator (→P.294)
-  Headlight high beam indicator (→P.295)
-  Automatic High Beam indicator (→P.296)
-  Front fog light indicator (→P.299)
-  Rear fog light indicator (→P.299)
-  Smart entry & start system indicator*¹ (→P.279)
-  Cruise control indicator (→P.337)
-  Dynamic radar cruise control indicator (→P.337)
-  Cruise control "SET" indicator (→P.337)
-  LTA indicator*² (→328)
-  Parking assist-sensor OFF indicator*^{3, 4} (→P.370)
-  PKSB OFF indicator*^{3, 5} (→P.376)
-  Slip indicator light*⁵ (→P.393)
(Flashes)

3
Vehicle status information and indicators

	VSC OFF indicator* ^{3, 5} (→P.394)		Sport mode indicator (→P.388)
	PCS warning light* ^{3, 5} (→P.318)		Trail Mode indicator (→P.390)
	BSM outside rear view mirror indicators* ^{5, 6} (→P.349)		“PASSENGER AIR BAG” indicator* ^{5, 9} (if equipped) (→P.46)
	BSM OFF indicator* ^{3, 5} (→P.349)		
	RCTA OFF indicator* ^{3, 5} (→P.349)		
	Brake hold standby indicator* ⁵ (→P.291)		
	Brake hold operated indicator* ⁵ (→P.291)		
	Security indicator (→P.71, 73)		
	“READY” indicator (→P.279)		
	Low outside temperature indicator* ⁷ (→P.169)		
	EV indicator (→P.84)		
	Parking brake indicator (→P.288)		
	EV drive mode indicator* ⁸ (→P.80)		
	AUTO EV/HV mode indicator* ⁸ (→P.80)		
	HV drive mode indicator* ⁸ (→P.80)		
	Hybrid battery charge mode indicator* ⁸ (→P.81)		
	Eco drive mode indicator (→P.388)		

*1: This light illuminates on the multi-information display with a message.

*2: Depending on the operating condition, the color and illuminating/flash-ing state of the light change.

*3: The light comes on when the system is turned off.

*4: Parking assist-sensor OFF indicator turns on when the power switch is turned to ON while the parking assist-sensor function is on. It will turn off after a few seconds.

*5: These lights turn on when the power switch is turned to ON to indicate that a system check is being performed. They will turn off after the hybrid system is on, or after a few seconds. There may be a malfunction in a system if the lights do not turn on, or turn off. Have the vehicle inspected by a SUZUKI dealer or a qualified workshop.

*6: This light illuminates on the outside rear view mirrors.

*7: When the outside temperature is approximately 3°C (37°F) or lower, the indicator will flash for approximately 10 seconds, then stay on.

*8: The displayed indicator changes according to the current plug-in hybrid system operation mode.

*9: This light illuminates on the center panel.

■ BSM (Blind Spot Monitor) outside rear view mirror indicators

In order to confirm operation, the BSM outside rear view mirror indicators illuminate when the power switch is turned to ON, or when the BSM function/RCTA function is enabled while the power switch is in ON.

If the system is functioning correctly, the BSM outside rear view mirror indicators will turn off after a few seconds.

If the BSM outside rear view mirror indicators do not illuminate or do not turn off, there may be a malfunction in the system.

If this occurs, have the vehicle inspected by a SUZUKI dealer or a qualified workshop.

Gauges and meters

The meters display various drive information.

Meter display

The display of the speedometer can be selected from two types, analog or digital. (→P.177)

■ Analog speedometer

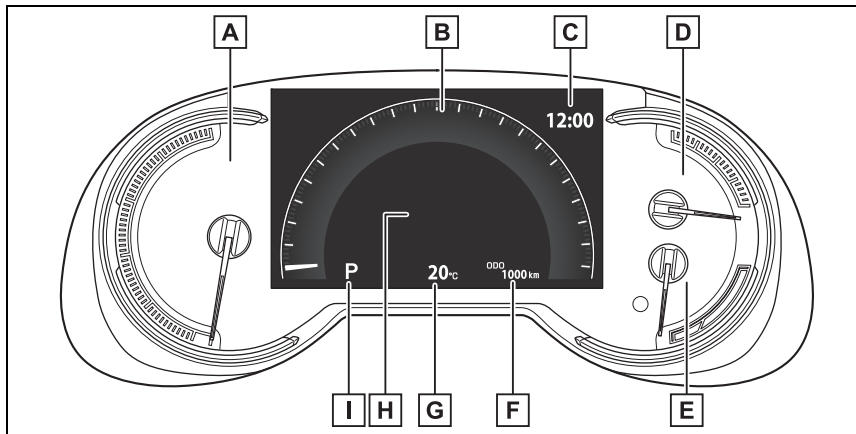

The units used on the meter and display may differ depending on the target region.

A Hybrid System Indicator

Displays the hybrid system output or regeneration level (→P.169)

B Speedometer

Displays the vehicle speed

C Clock

Automatically adjusts the time by using the GPS time information (GPS clock).
For details, refer to "Multimedia Owner's Manual".

D Fuel gauge

Displays the quantity of fuel remaining in the tank

E SOC (State of Charge) gauge

Displays the amount of charge remaining in the traction battery.

When the gauge is in the green zone, EV driving is possible. When the gauge is in the blue zone, EV driving is no longer possible (in this situation, the vehicle switches

to HV mode). Charge the hybrid battery (traction battery) to allow EV driving.

F Odometer, trip meter and instrument cluster light control display

Odometer:

Displays the total distance that the vehicle has been driven

Trip meter:

Displays the distance the vehicle has been driven since the meter was last reset.

Trip meters “A” and “B” can be used to record and display different distances independently.

Instrument cluster light control:

Displays the brightness of the instrument cluster lights that can be adjusted.

G Outside temperature (→P.169)

H Multi-information display

Presents the driver with a variety of driving-related data (→P.171)

Displays warning messages if a malfunction occurs (→P.518)

I Shift position and shift range indicator

Displays the selected shift position or selected shift range (→P.283)

■ Digital speedometer

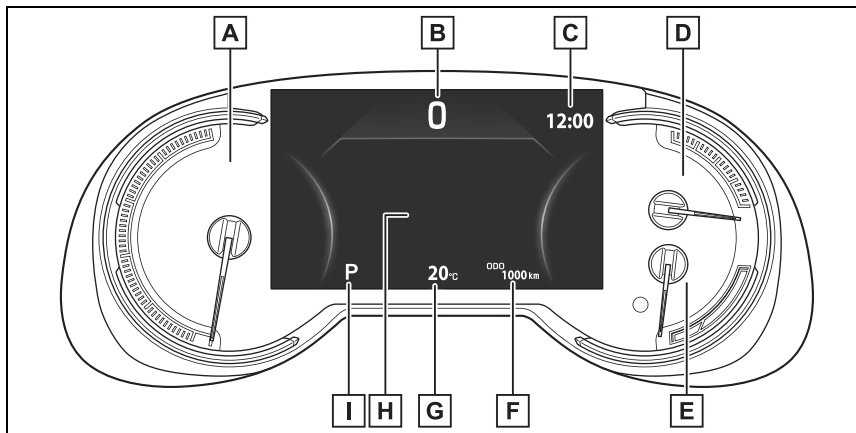

The units used on the meter and display may differ depending on the target region.

A Hybrid System Indicator

Displays the hybrid system output or regeneration level (→P.169)

B Speedometer

Displays the vehicle speed

C Clock

Automatically adjusts the time by using the GPS time information (GPS clock).
For details, refer to "Multimedia Owner's Manual".

D Fuel gauge

Displays the quantity of fuel remaining in the tank

E SOC (State of Charge) gauge

Displays the amount of charge remaining in the traction battery.

When the gauge is in the green zone, EV driving is possible. When the gauge is in the blue zone, EV driving is no longer possible (in this situation, the vehicle switches to HV mode). Charge the hybrid battery (traction battery) to allow EV driving.

F Odometer, trip meter and instrument cluster light control display

Odometer:

Displays the total distance that the vehicle has been driven

Trip meter:

Displays the distance the vehicle has been driven since the meter was last reset. Trip meters A and B can be used to record and display different distances independently.

Instrument cluster light control:

Displays the brightness of the instrument cluster lights that can be adjusted.

G Outside temperature (→P.169)

H Multi-information display

Presents the driver with a variety of driving-related data (→P.171)

Displays warning messages if a malfunction occurs (→P.518)

I Shift position and shift range indicator

Displays the selected shift position or selected shift range (→P.283)

■ **The meters and display illuminate when**

The power switch is in ON.

■ **When changing driving mode**

● Speedometer color is changed following the selected driving mode. (→P.388)

● Speedometer color is changed following the selected driving mode or when Trail Mode is turned on. (→P.388, 390)

■ **If the units of measure for speedometer can be changed (if equipped)**

The other units of measure is also displayed as shown in the illustrations.

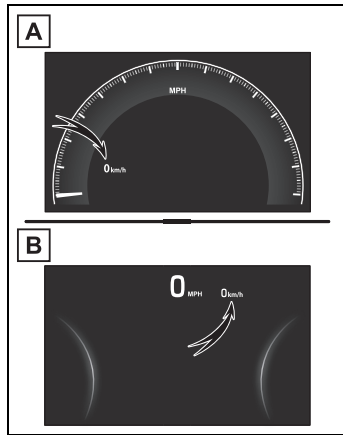

A Analog speedometer

B Digital speedometer

Hybrid System Indicator

The display contents of the Hybrid System Indicator are different in EV mode and HV mode.

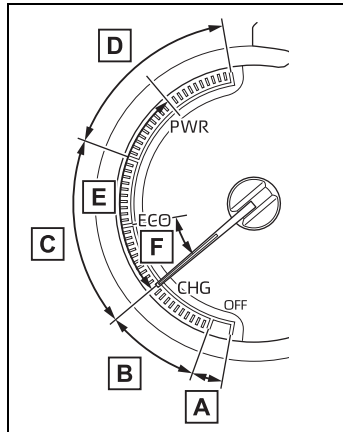

A READY OFF area

Shows that the hybrid system is not operating.

B Charge area

Shows regeneration* status. Regenerated energy will be used to charge the

hybrid battery (traction battery).

C Eco area

Shows that the vehicle is being driven in an Eco-friendly manner.

By keeping the indicator needle within Eco area, more Eco-friendly driving can be achieved.

D Power area

Shows that an Eco-friendly driving range is being exceeded (during full power driving etc.)

E EV driving area (EV mode or AUTO EV/HV mode)

Shows that the vehicle is driven using only the electric motor (traction motor).

F Hybrid Eco area (HV mode)

Shows that gasoline engine power is not being used very often.

The gasoline engine will automatically stop and restart under various conditions.

*: When used in this manual, “regeneration” refers to the conversion of energy created by the movement of the vehicle into electrical energy.

In the following situation, the Hybrid System Indicator does not operate.

- “READY” indicator is not illuminated.
- The shift lever is in a range other than D or S.

Outside temperature display

- In the following situations, the correct outside temperature may not be displayed, or the display may take longer than normal to change.
 - When stopped (including when using “My Room Mode”), or driving at low speeds (less than 20 km/h [12 mph])
 - When the outside temperature has

changed suddenly (at the entrance/exit of a garage, tunnel, etc.)

- When “--” or “E” is displayed, the system may be malfunctioning. Take your vehicle to a SUZUKI dealer or a qualified workshop.
- Displays the outside temperature within the range of -40°C (-40°F) to 50°C (122°F).
- When the outside temperature is approximately 3°C (37°F) or lower, the indicator  will flash for approximately 10 seconds, then stay on.

■ **Liquid crystal display**

→P.172

■ **Customization**

Settings (e. g. meter display) can be changed on the  screen of the multi-information display. (→P.177)

 **WARNING**

■ **The information display at low temperatures**

Allow the interior of the vehicle to warm up before using the liquid crystal information display. At extremely low temperatures, the display monitor may respond slowly, and display changes may be delayed.

For example, there is a lag between the driver's shifting and the new shift range appearing on the display. This lag could cause the driver to down-shift again, causing rapid and excessive engine braking and possibly an accident resulting in death or injury.

 **NOTICE**

■ **To prevent damage to the engine and its components**

- The engine may be overheating if “Engine Coolant Temp High Stop in a Safe Place See Owner’s Manual” is shown on the multi-information display. In this case, immediately stop the vehicle in a safe place, and check the engine after it has cooled completely. (→P.540)

Using the “ODO TRIP” switch

Switches the items of the odometer, trip meter A, trip meter B and the brightness of the instrument cluster lights by pressing the “ODO TRIP” switch.

- When the trip meter is displayed, pressing and holding the switch will reset the trip meter.
- When the instrument cluster light control display is displayed, pressing and holding the switch will adjust the brightness of the instrument cluster lights.

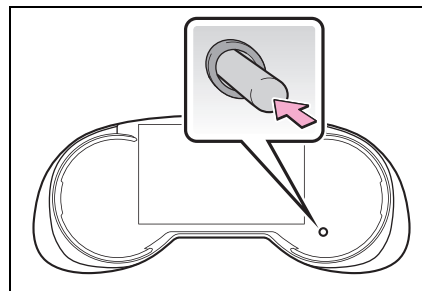

Instrument cluster brightness adjustment

The instrument cluster brightness levels when the tail lights are on and off can be adjusted individually. However, when the surroundings are bright (daytime, etc.), turning on the tail lights will not change the instrument cluster brightness.

Adjusting the clock

The clock can be adjusted on the multimedia system.

Refer to “Multimedia Owner’s Manual”.

Multi-information display

The multi-information display is used to display fuel efficiency related information and various types of driving-related information. The multi-information display can also be used to change the display settings and other settings.

Display contents

Following information is displayed on the multi-information display.

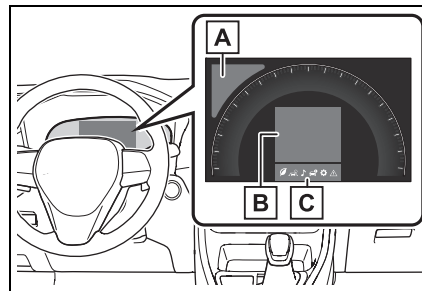

A Driving support system information

Displays recognized signs while the RSA system is operating. (→P.333)

Displays an image when the following systems are operating and a menu icon

other than  is selected:

- LTA (Lane Tracing Assist) (→P.323)
- Dynamic radar cruise control with full-speed range (→P.337)

B Information display area

A variety of information can be displayed by selecting a menu icon.

Additionally, warning or sugges-

tion/advice pop-up displays will be displayed in some situations.

C Menu icons (→P.172)

■ The multi-information display is displayed when

The power switch is in ON.

■ When changing driving mode

- Background color of the multi-information display is changed following the selected driving mode. (→P.388)
- Background color of the multi-information display is changed following the selected driving mode or when Trail Mode is turned on. (→P.388, 390)

■ Liquid crystal display

Small spots or light spots may appear on the display. This phenomenon is characteristic of liquid crystal displays, and there is no problem continuing to use the display.

Changing the display

The multi-information display is operated using the meter control switches.

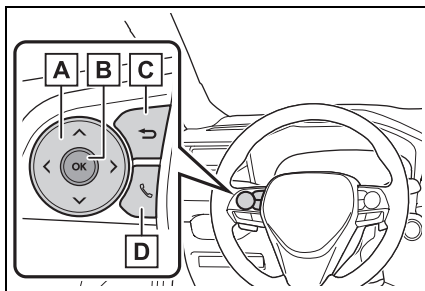

- A** Scroll the screen*/switch the display*/move the cursor
- B** Press: Enter/Set
Press and hold: Reset/Display customizable items

C Return to the previous screen

D Call sending/receiving and history display

Linked with the hands-free system, sending or receiving call is displayed. For details regarding the hands-free system, refer to "Multimedia Owner's Manual".

*: On screens where the screen can be scrolled and the display can be switched, a scroll bar or a round icon that shows the number of registered screens is displayed.

! WARNING

■ Caution for use while driving

For safety, avoid operating the meter control switch while driving as much as possible, and do not look continuously at the multi-information display while driving. Stop the vehicle and operate the meter control switch. Failure to do so may cause a steering wheel operation error, resulting in an unexpected accident.

Menu icons

Information related to each icon can be displayed by selecting the icon with the meter control switches.

Some of the information may be displayed automatically depending on the situation.

Icon	Display
	Driving information display (→P.173)
	Driving support system information display (→P.176)
	Audio system-linked display (→P.176)
	Vehicle information display (→P.176)
	Settings display (→P.177)
	Warning message display (→P.181)

Driving information display

Select to display fuel consumption data in various forms.

■ **Power Consumption/Fuel Economy**

The display contents are different in EV mode or AUTO EV/HV mode, and HV mode.

- ▶ EV mode or AUTO EV/HV mode

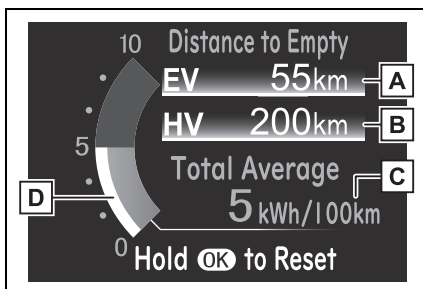

A EV driving range

B Distance to empty

Displays the driving range with remaining fuel. (→P.176)

Displays the EV driving range with charge remaining in the hybrid battery (traction battery). (→P.96)

C Average power consumption

Displays the average power consumption since the function was reset or the average power consumption after starting.^{*1, 2, 3}

The average power consumption selected by “Power Consumption” on the screen is displayed. (→P.177)

D Current power consumption

Displays the instantaneous current power consumption.

^{*1}: Use the displayed power consumption as a reference only.

^{*2}: Average power consumption since the function was reset can be reset by pressing and holding .

^{*3}: Average power consumption after starting is reset each time the hybrid system stops.

- ▶ HV mode

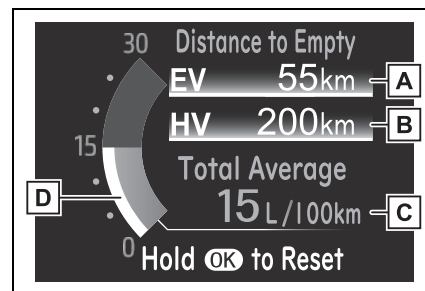

A EV driving range

Displays the EV driving range with

charge remaining in the hybrid battery (traction battery). (→P.84)

B Distance to empty

Displays the driving range with remaining fuel. (→P.176)

C Average fuel economy

Displays the average fuel economy since the function was reset or the average fuel economy after starting or refueling.*1, 2, 3

The average fuel economy selected by “Fuel Economy” on the  screen is displayed. (→P.177)

D Current fuel economy

Displays the instantaneous current fuel Economy.

*1: Use the displayed fuel consumption as a reference only.

*2: Average fuel economy since the function was reset can be reset by pressing and holding .

*3: Average fuel economy after starting is reset each time the hybrid system stops.

ECO Accelerator Guidance/“Eco Score”

Displays a reference operation range for using the accelerator pedal according to driving conditions, and a score result that evaluates the current driving status.

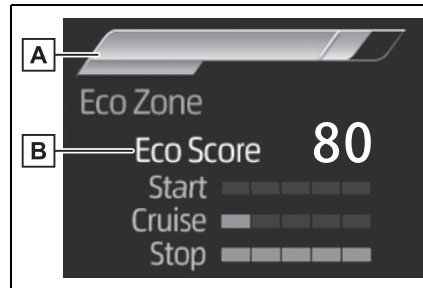

A ECO Accelerator Guidance

B “Eco Score”

► ECO Accelerator Guidance

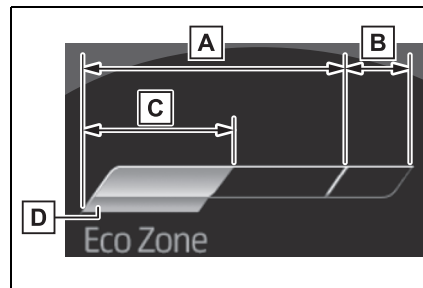

A ECO area

Shows that the vehicle is being driven in an Eco-friendly manner.

B Power area

Shows that an Eco-friendly driving range is being exceeded (during full power driving etc.).

C Current acceleration

D Reference operation range

A zone is displayed in blue under the Eco area which can be used as a reference operation range for using the accelerator pedal according to driving conditions such as starting off and cruising.

The ECO Accelerator Guidance display changes according to the driving status,

such as when starting off or cruising. It is easier to drive in an Eco-friendly manner by driving according to the display showing the accelerator pedal operations and staying within the reference operation range.

► “Eco Score”

The driving status for the following 3 situations are evaluated in 5 levels: Smooth start-off acceleration (“Start”), driving without sudden acceleration (“Cruise”) and smooth stopping (“Stop”). Each time the vehicle is stopped, a score result is displayed out of a perfect score of 100 points.

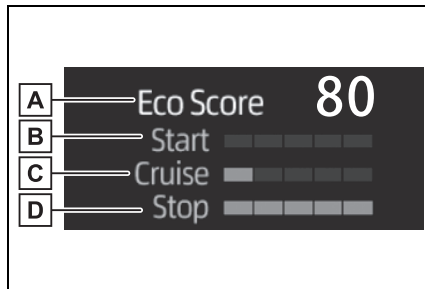

- A** Score result
- B** “Start”
- C** “Cruise”
- D** “Stop”

3 situations are displayed with each icon while driving.

How to read the bar display:

Score	Bar display
Unrated	
Low	
High	

After starting off, “Eco Score” display does not start until the vehicle speed exceeds approximately 20 km/h (12 mph).

The “Eco Score” is reset each time the vehicle starts off to start a new evaluation.

When the hybrid system stops, the current total score result is displayed.*

*: The score result is displayed only when “Eco Score” is selected for “Closing Display”. (→P.177)

■ **EV Ratio/EV Driving Ratio**

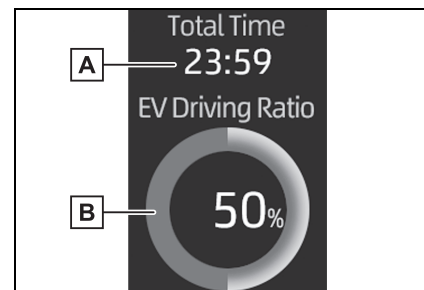

A Elapsed time after starting
Displays the elapsed time since hybrid system was started.*

B EV driving ratio after starting
Displays the percentage of EV driving since the hybrid system was started.*

*: It is reset each time the hybrid system stops.

Electricity consumption

When the unit is set to “km/h”:

Electricity consumption is the consumption rate of the electricity when EV driving is performed and equivalent to the fuel consumption for the gasoline vehicles. For this vehicle, electricity consumed per 100 km (“kWh/100 km”) is displayed as electricity consumption on each screen.

When the unit is set to “MPH” (if equipped):

Electricity consumption is the consumption rate of the electricity when EV driving is performed and equivalent to the fuel consumption for the gasoline vehicles. For this vehicle, driven distance per kWh of electricity consumed (“miles/kWh”) is displayed as electricity consumption on each screen.

EV driving range

- When the air conditioning system is operating,  is displayed next to the EV driving range and the EV driving range with the air conditioning system on is displayed.
- The EV driving range may shorten even when not driving due to power consumption by the system.
- For details, refer to “EV driving range” (→P.96)

Distance to empty

- This distance is computed based on your average fuel consumption. As a result, the actual distance that can be driven may differ from that displayed.
- When only a small amount of fuel is added to the tank, the display may not be updated. When refueling, turn the power switch off. If the vehicle is refueled without turning the power switch off, the display may not be updated.
- When “Refuel” is displayed, the remaining fuel amount is low and the distance that can be driven with the remaining fuel cannot be calculated. Refuel immediately.

ECO Accelerator Guidance/“Eco Score” will not operate when

The ECO Accelerator Guidance/“Eco Score” will not operate in the following situations:

- The Hybrid System Indicator is not operating.
- The vehicle is being driven using the dynamic radar cruise control with full-speed range.

Driving support system information display**Driving support system information display**

Select to display the operational status of the following systems:

- LTA (Lane Tracing Assist) (→P.323)
- Dynamic radar cruise control with full-speed range (→P.337)

Audio system-linked display

Select to enable selection of an audio source or track on the display.

Vehicle information display**Drive information**

2 items that are selected using the “Drive Info Items” setting (average speed, distance and total time) can be displayed vertically.

The displayed information changes according to the “Drive Info Type” setting (since the system was started or between resets).

(→P.177)

Use the displayed information as a reference only.

Following items will be displayed.

- “Trip”
 - “Average Speed”: Displays the average vehicle speed since hybrid system start*
 - “Distance”: Displays the distance driven since hybrid system start*
 - “Total Time”: Displays the elapsed time since hybrid system start*
- *: These items are reset each time the hybrid system stops.
- “Total”
 - “Average Speed”: Displays the average vehicle speed since the display was reset*
 - “Distance”: Displays the distance driven since the display was reset*
 - “Total Time”: Displays the elapsed time since the display was reset*
- *: To reset, display the desired item and press and hold .

■ Energy monitor

→P.182

■ Tire pressure

→P.454

■ AWD system display

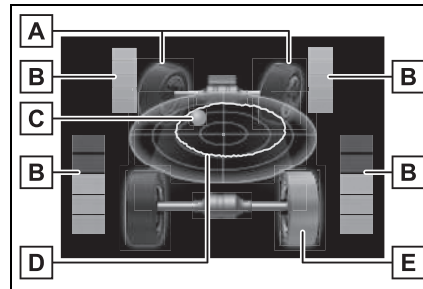

A Front tire direction display

Displays the operation amount and direction of the steering wheel via changes to the front tires on the display.

B Torque distribution display

Displays the drive status of each wheel in 6 steps from 0 to 5.

C G-force display*

Displays the size and direction of the G-force applied to the vehicle via changes to the position of the ball on the display.

D Maximum G-force course*

This item is linked with the G-force display and the course of the past movement of the ball is displayed.

Press and hold  to reset the record.

E Wheel spin display









When a tire is spinning, its icon on the display changes its color and blinks.

*: This item is displayed only when driving mode is set to sport mode.

Settings display

Vehicle settings and the content displayed on the screen can be changed by using the meter control switches.

■ **Setting procedure**

- 1 Operate  or  of the meter control switches and select .
- 2 Operate  or  of the meter control switches and select the desired item.
 - If the function is turned on and off or the volume, etc. is changed on the setting screen, the setting is changed each time  is pressed.
 - For functions that allow operation contents, display contents, etc., of function to be selected, the setting screen is displayed by pressing and holding . When the setting screen is displayed, select the setting or desired value (time, etc.) with .
- 3 After changing the settings, press  of the meter control switches.

■  **LTA (Lane Tracing Assist)**
(→P.323)

Select to set up the following items.

- “Lane Center”
Select to enable/disable the lane centering function.
- “Steering Assist”
Select to enable/disable steering wheel assistance.
- “Alert”
Select to change each notification method of the lane departure alert.

- “Sensitivity”

Select to set the lane departure alert sensitivity.

- “Sway Warning”

Select to enable/disable the vehicle sway warning.

- “Sway Sensitivity”

Select to set the vehicle sway warning sensitivity.

■  **PCS (Pre-Collision System)** (→P.316)

Select to set up the following items.

- PCS on/off

Select to enable/disable the pre-collision system.

- “Sensitivity”

Select to change the pre-collision warning timing.

■  **BSM (Blind Spot Monitor)**
(→P.349)

Select to set up the following items.

- BSM (Blind Spot Monitor) on/off

Select to enable/disable the BSM system.

- “Brightness”

Select to switch the brightness of the outside rear view mirror indicators.
(→P.349)

- “Sensitivity”

Select to change the alert timing for an approaching vehicle.

■  **(Parking assist-sensor)**
(→P.369)

Select to set up the following items.

- Parking assist-sensor on/off

Select to enable/disable the parking assist-sensor.

- “Volume”

Select to set the volume of the buzzer which sounds when the Parking assist-sensor is operated.

■ RCTA (Rear Crossing Traffic Alert) (→P.349)

- RCTA (Rear Crossing Traffic Alert) on/off

Select to enable/disable the RCTA system.

- “Volume”

Select to change the RCTA buzzer volume.

■ PKSB (Parking Support Brake System) (→P.375)

Select to enable/disable the Parking Support Brake function.

■ RSA (Road Sign Assist) (→P.333)

Select to set up the following items.

- Road Sign Assist on/off

Select to enable/disable the RSA system.

- “Notification Method”

Select to change each notification method used to notify the driver when the system recognizes excess speed and no overtaking.

- “Notification Level”

Select to change each notification level used to notify the driver when the system recognizes a speed limit sign.

■ DRCC(RSA) (→P.345)

Select to enable/disable the

Dynamic Radar Cruise Control with Road Sign Assist.

■ Vehicle Settings

- “Charging Settings”

Select to set up the following items.

- “Charging Schedule”

Select to register or change the charging schedule. (→P.136)

- “Charging Current”

Select to change the charging current. (→P.118)

- “Battery Heater”

Select to enable/disable the battery heater. (→P.121)

- “Battery Cooler”

Select to enable/disable the battery cooler. (→P.121)

-  PBD (Power Back Door) (→P.197)

Select to set up the following items.

- System settings

Select to enable/disable the power back door system.

- “Hands Free”

Select to enable/disable the Hands Free Power Back Door.

- “Opening Adjustment”

Select the open position when power back door is fully open.

- “Volume”

Select to set the volume of the buzzer which sounds when the power back door system operates.

- “TPWS” (Tire Pressure Warning System) (→P.454)

- “Setting Pressure”

Select to initialize the tire pressure

warning system.

- “Identifying Each Wheel & Position”

Select to register the ID codes of the tire pressure sensors to the tire pressure warning system.

- “Setting Unit”

Select to change the units of measure displayed.

- “Rear Seat Reminder” (→P.193)

Select to enable/disable the rear seat reminder.

■ Settings

- “Language”

Select to change the language on the multi-information display.

- “Units”

Select to change the units of measure displayed.

- “Meter Type”

Select to change the speedometer display.

-  (EV indicator) (→P.84)

Select to enable/disable the EV indicator.

-  (Driving information display settings)

Select to set up the following items.

- “Hybrid System”

Select to enable/disable the ECO Accelerator Guidance (→P.174).

- “Fuel Economy”

Select to change the display on Fuel Economy (→P.173).

- “Power Consumption”

Select to change the display on Power Consumption (→P.173).

-  (Audio settings)

Select to enable/disable  screen.

-  (Vehicle information display settings)

- “Display Contents”

Select to set up the following items.

“Energy monitor”:

Select to enable/disable the Energy monitor (→P.182)

AWD:

Select to enable/disable the AWD system display (→P.177).

- “Drive Info Type”

Select to change the drive information type display between trip and total. (→P.176).

- “Drive Info Items”

Select to set the items on the upper and lower side of the drive information screen from three items, average speed, distance and total time.

- “Closing Display”

Select to set the items displayed when the power switch is turned off.

- “Pop-Up Display”

Select to enable/disable the following pop-up displays, which may appear in some situations.

- Incoming call display of the hands-free phone system

- Audio operation

- Volume operation

- Voice control

- “Calender”

Select to set up the calender.

This can only be set if GPS calibration of clock is turned off in the multimedia

system settings.

- “MID OFF”

A blank screen is displayed

- “Default Settings”

Select to reset the meter display settings.

■ Suspension of the settings display

- In the following situations, operation of the settings display will be temporarily suspended.
 - When a warning message appears on the multi-information display
 - When the vehicle begins to move
- Settings for functions not equipped to the vehicle are not displayed.
- When a function is turned off, the related settings for that function are not selectable.

⚠ WARNING

■ Cautions during setting up the display

As the hybrid system needs to be operating during setting up the display, ensure that the vehicle is parked in a place with adequate ventilation. In a closed area such as a garage, exhaust gases including harmful carbon monoxide (CO) may collect and enter the vehicle. This may lead to death or a serious health hazard.

⚠ NOTICE

■ During setting up the display

To prevent 12-volt battery discharge, ensure that the hybrid system is operating while setting up the display features.

Warning message display

Select to display warning messages and measures to be taken if

a malfunction is detected. (→P.518)

Suggestion function

Displays suggestions to the driver in the following situations. To select a response to a displayed suggestion, use the meter control switches.

■ Suggestion to enable the power back door

If the power back door system is disabled on the  screen and the power back door switch on the instrument panel is operated, a suggestion message will be displayed asking if you wish to enable the power back door system. To enable the power back door system, select “Yes”.

After enabling the power back door system, press the power back door switch again to open or close the power back door.

■ Suggestion to turn on the headlights

If the headlight switch is in other than  or AUTO, and the vehicle speed is 5 km/h (3 mph) or higher for a certain amount of time when the surroundings are dark, a suggestion message will be displayed.

■ Suggestion to turn off the headlights

If the headlights are left on for a certain amount of time after the power switch has been turned off, a

suggestion message will be displayed.

■ **Suggestion to close the power windows (linked to windshield wiper operation)**

If the windshield wipers are operated with a power window open, a suggestion message will be displayed asking if you wish to close the power windows. To close all of the power windows, select "Yes".

■ **Suggestion to close the power windows (driving at high speeds)**

If the vehicle speed exceeds a certain speed with a power window open, a suggestion message will be displayed asking if you wish to close the power windows. To close all of the power windows, select "Yes".

■ **Customization**

The suggestion function can be turned on/off. (Customizable features: →P.556)

Energy monitor/consumption screen

You can view the status of your vehicle on the multi-information display and the audio system screen.

System components

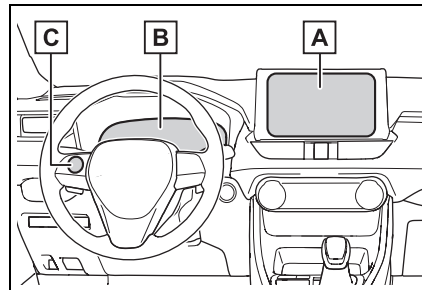

- A Audio system screen
- B Multi-information display
- C Meter control switches (→P.172)

Energy monitor

The energy monitor can be used to check the vehicle drive status, hybrid system operation status and energy regeneration status.

■ **Display**

- ▶ Multi-information display

Press **<** or **>** of the meter control switches on the steering wheel

and select , and then press

^ or **v** to select the energy monitor display.

- ▶ Audio system screen
- 1 Press the "MENU" button.
- 2 Select "Info" on the "Menu" screen.

If a screen other than "Energy monitor" is displayed, select "Energy".

■ **Reading the display**

The arrows will appear in accordance with the energy flow. When there is no energy flow, arrows will not be displayed.

The color of the arrows will change as follows

Green: When the hybrid battery (traction battery) is regenerated or charged.

Yellow: When the hybrid battery (traction battery) is in use.

Red: When the gasoline engine is in use.

- ▶ Multi-information display

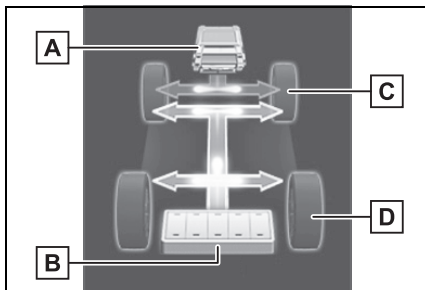

The image shows all the arrows as an example. The actual display will vary depending on conditions.

- A** Gasoline engine
- B** Hybrid battery (traction battery)
- C** Front tire
- D** Rear tire

- ▶ Audio system screen (except when charging)

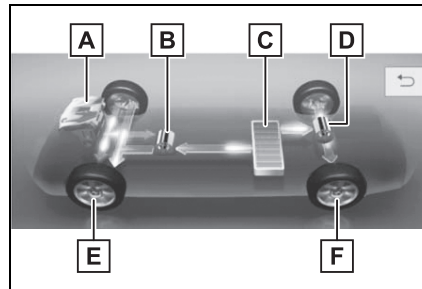

The image shows all the arrows as an example. The actual display will vary depending on conditions.

- A** Gasoline engine
- B** Front electric motor (traction motor)
- C** Hybrid battery (traction battery)
- D** Rear electric motor (traction motor)
- E** Front tire
- F** Rear tire

- ▶ Audio system screen (when charging)

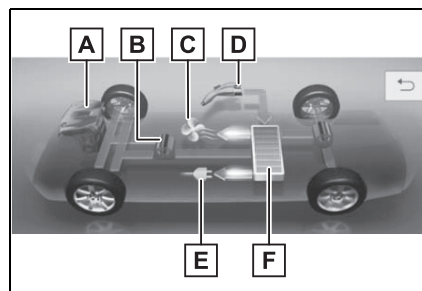

The image shows all the arrows as an example. The actual display will vary depending on conditions.

- A** Gasoline engine

- B** Front electric motor (traction motor)
- C** Air conditioning system operation*
- D** Charging connector
- E** Power outlet (220 VAC)
- F** Hybrid battery (traction battery)

*: The icon is displayed when the air conditioning system is operating.

- ▶ Audio system screen (“Home” screen)

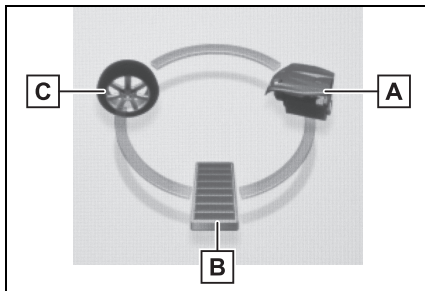

The image shows all the arrows as an example. The actual display will vary depending on conditions.

- A** Gasoline engine
- B** Hybrid battery (traction battery)
- C** Tire

Color of the hybrid battery (traction battery) on the display

It will be green when the hybrid battery (traction battery) is being charged, and yellow when the hybrid battery (traction battery) is being used.

Remaining charge amount warning of hybrid battery (traction battery)

- The buzzer sounds intermittently when the hybrid battery (traction bat-

tery) remains without charging while the shift lever is in N, or the remaining charge amount drops below a certain level. If the remaining charge amount drops further, the buzzer sounds continuously.

- When a warning message is shown on the multi-information display and the buzzer sounds, follow the instructions displayed on the screen to perform troubleshooting.

Color of the gasoline engine on the audio system screen

It will be blue when the engine is warming up, and it will turn to red when the warming up is finished.

Hybrid system output may be restricted when the gasoline engine is displayed in blue.

Consumption (Audio system)

Display

- 1 Press the “MENU” button.
- 2 Select “Info” on the “Menu” screen.
- 3 Select “Trip information” or “History”.

Trip information

If a screen other than “Trip information” is displayed, select “Trip information”.

The image is an example only, and may vary slightly from actual conditions.

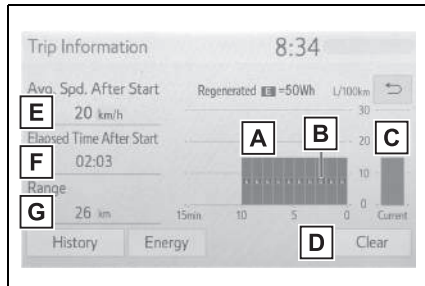

- A** Fuel consumption in the past 15 minutes
- B** Regenerated energy in the past 15 minutes
- One symbol indicates 50 Wh. Up to 5 symbols are shown.
- C** Current fuel consumption
- D** Resetting the consumption data
- E** Average vehicle speed since the hybrid system was started
- F** Elapsed time since the hybrid system was started
- G** Cruising range (→P.185)

Average fuel consumption for the past 15 minutes is divided by color into past averages and averages attained since the power switch was last turned to ON. Use the displayed average fuel consumption as a reference.

■ History

If a screen other than “History” is displayed, select “History”.

The image is an example only, and may vary slightly from actual conditions.

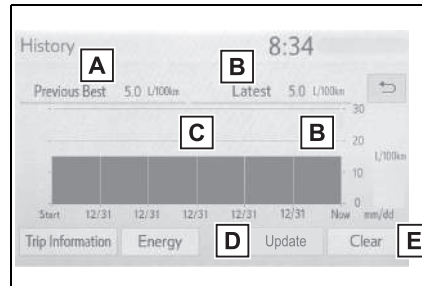

- A** Best recorded fuel consumption
- B** Latest fuel consumption
- C** Previous fuel consumption record
- Displays the daily average fuel consumption. (Instead of the date, “Trip 1” through “Trip 5” will be displayed.)
- D** Updating the latest fuel consumption data
- E** Resetting the history data

The average fuel consumption history is divided by color into past averages and the average fuel consumption since the last time updated. Use the displayed average fuel consumption as a reference.

■ Updating the history data

Update the latest fuel consumption by selecting “Update” to measure the current fuel consumption again.

■ Resetting the data

The fuel consumption data can be deleted by selecting “Clear”.

■ Cruising range

Displays the estimated maximum distance that can be driven with the quantity of fuel remaining.

This distance is computed based on your average fuel consumption. As a result, the actual distance that can be driven may differ from that displayed.

- 4-1. Key information**
 - Keys.....**188**
- 4-2. Opening, closing and locking the doors**
 - Side doors**191**
 - Back door**195**
 - Smart entry & start system**206**
- 4-3. Adjusting the seats**
 - Front seats.....**249**
 - Rear seats**250**
 - Head restraints**252**
- 4-4. Adjusting the steering wheel and mirrors**
 - Steering wheel.....**254**
 - Inside rear view mirror**255**
 - Outside rear view mirrors .**256**
- 4-5. Opening, closing the windows**
 - Power windows.....**258**

Keys

Key types

The following keys are provided with the vehicle.

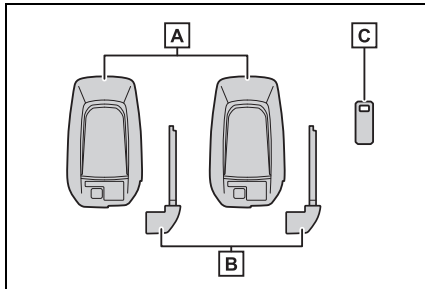

A Electronic keys

- Operating the smart entry & start system (→P.206)
- Operating the wireless remote control function (→P.189)

B Mechanical keys

C Key number plate

■ When riding in an aircraft

When bringing an electronic key onto an aircraft, make sure you do not press any buttons on the electronic key while inside the aircraft cabin. If you are carrying an electronic key in your bag etc., ensure that the buttons are not likely to be pressed accidentally. Pressing a button may cause the electronic key to emit radio waves that could interfere with the operation of the aircraft.

■ Electronic key battery depletion

- The standard battery life is 1 to 2 years.
- If the battery becomes low, an alarm will sound in the cabin and a message will be displayed on the multi-information display when the hybrid system stops.

- To reduce key battery depletion when the electronic key is to not be used for long periods of time, set the electronic key to the battery-saving mode. (→P.208)

- As the electronic key always receives radio waves, the battery will become depleted even if the electronic key is not used. The following symptoms indicate that the electronic key battery may be depleted. Replace the battery when necessary.
 - The smart entry & start system or the wireless remote control does not operate.
 - The detection area becomes smaller.
 - The LED indicator on the key surface does not turn on.

You can replace the battery by yourself (→P.484). However, as there is a danger that the electronic key may be damaged, it is recommended that replacement is carried out by a SUZUKI dealer or a qualified workshop.

- To avoid serious deterioration, do not leave the electronic key within 1 m (3 ft.) of the following electrical appliances that produce a magnetic field:
 - TVs
 - Personal computers
 - Cellular phones, cordless phones and battery chargers
 - Table lamps
 - Induction cookers
- If the electronic key is near the vehicle for longer than necessary, even if the smart entry & start system is not operated, the key battery may become depleted faster than normal.

■ If a message regarding the state of the electronic key or power switch mode, etc. is shown

To prevent trapping the electronic key inside the vehicle, leaving the vehicle carrying the electronic key on your person without turning the power switch to OFF or other passengers from unintentionally taking the key out of the vehicle, etc., a message that prompts the user to

confirm the state of the electronic key or power switch mode may be shown on the multi-information display. In those cases, follow the instructions on the display immediately.

■ **If “Key Battery Low Replace Key Battery” is displayed on the multi-information display**

The electronic key has a low battery. Replace the electronic key battery. (→P.484)

■ **Replacing the battery**

→P.484

■ **Confirmation of the registered key number**

The number of keys already registered to the vehicle can be confirmed. Ask a SUZUKI dealer or a qualified workshop for details.

■ **If “A New Key has been Registered Contact Your Dealer for Details” is displayed on the multi-information display**

This message will be displayed each time the driver’s door is opened when the doors are unlocked from the outside for approximately 10 days after a new electronic key has been registered. If this message is displayed but you have not had a new electronic key registered, ask a SUZUKI dealer or a qualified workshop to check if an unknown electronic key (other than those in your possession) has been registered.

	<p>NOTICE</p>
<p>■ To prevent key damage</p> <ul style="list-style-type: none"> ● Do not drop the keys, subject them to strong shocks or bend them. ● Do not expose the keys to high temperatures for long periods of time. ● Do not get the keys wet or wash them in an ultrasonic washer, etc. 	

- Do not attach metallic or magnetic materials to the keys or place the keys close to such materials.

- Do not disassemble the keys.

- Do not attach a sticker or anything else to the surface of the electronic key.

- Do not place the keys near objects that produce magnetic fields, such as TVs, audio systems and induction cookers.

- Do not place the keys near medical electrical equipment such as low-frequency therapy equipment or microwave therapy equipment, and do not receive medical attention with the keys on your person.

■ **Carrying the electronic key on your person**

Carry the electronic key 10 cm (3.9 in.) or more away from electric appliances that are turned on. Radio waves emitted from electric appliances within 10 cm (3.9 in.) of the electronic key may interfere with the key, causing the key to not function properly.

■ **In case of a smart entry & start system malfunction or other key-related problems**

→P.533

■ **When an electronic key is lost**

→P.531

Wireless remote control

The electronic keys are equipped with the following wireless remote control:

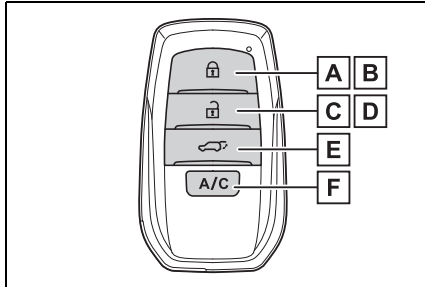

- A** Locks all the doors (→P.191)
- B** Closes the side windows* (→P.191)
- C** Unlocks all the doors (→P.191)
- D** Opens the side windows* (→P.191)
- E** Opens and closes the power back door (→P.197)
- F** Operates Remote Air Conditioning System (→P.413)

*: These settings must be customized at a SUZUKI dealer or a qualified workshop.

Using the mechanical key

To take out the mechanical key, slide the release lever **A** and take the key out.

The mechanical key can only be inserted in one direction, as the key only has grooves on one side. If the key cannot be inserted in a lock cylinder, turn it over and re-attempt to insert it.

After using the mechanical key, store it in the electronic key. Carry the mechanical key together with the electronic key. If the electronic key battery is depleted

or the entry function does not operate properly, you will need the mechanical key. (→P.533)

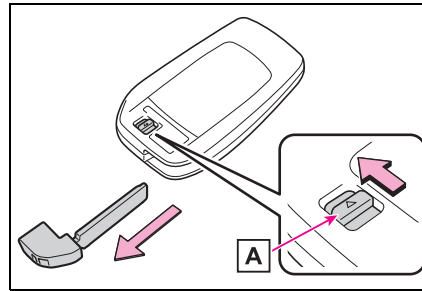

■ When required to leave the vehicle's key with a parking attendant

Lock the glove box as circumstances demand. (→P.421)
Remove the mechanical key for your own use and provide the attendant with the electronic key only.

■ If you lose your mechanical keys →P.531

■ If a wrong key is used

The key cylinder rotates freely to isolate inside mechanism.

Side doors

The vehicle can be locked and unlocked using the entry function, wireless remote control, door lock switches or inside lock buttons.

Charging port lid and charging connector will also be locked and unlocked. (→P.114)

Unlocking and locking the doors from the outside

■ Using the entry function

Carry the electronic key to enable this function.

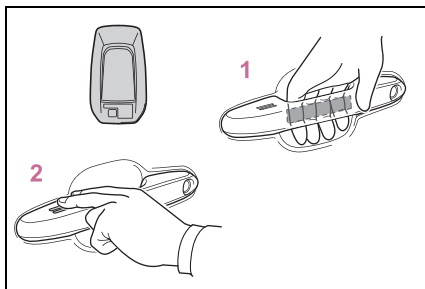

- 1 Grip the front door handle to unlock the doors.

Make sure to touch the sensor on the back of the handle.

The doors cannot be unlocked for 3 seconds after the doors are locked.

- 2 Touch the lock sensor (the indentation on the upper part of the door handle) to lock the doors.

Check that the door is securely locked.

■ Using the wireless remote control

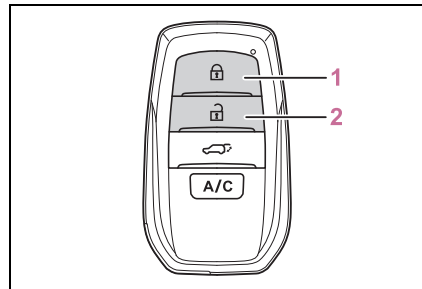

- 1 Locks all the doors

Check that the door is securely locked. Press and hold to close the side windows.*



- 2 Unlocks all the doors

Press and hold to open the side windows.*

*: These settings must be customized at a SUZUKI dealer or a qualified workshop.

■ Switching the door unlock function



It is possible to set which doors the entry function unlocks using the wireless remote control. Operate the switching operation in the vehicle or within approximately 1 m (3.2 ft.) of the vehicle.

- 1 Turn the power switch to OFF.
- 2 Cancel the intrusion sensor and tilt sensor of the alarm system to prevent unintended triggering of the alarm while changing the settings. (→P.74)
- 3 When the indicator light on the key surface is not on, press and hold  or  for approximately 5 seconds while pressing and holding  .

The setting changes each time an operation is performed, as shown below.

(When changing the setting continu-

ously, release the buttons, wait for at least 5 seconds, and repeat step 3.)

Multi-information display/Beep	Unlocking function
 (Left-hand drive vehicles)	Holding the driver's door handle unlocks only the driver's door.
 (Right-hand drive vehicles) Exterior: Beeps 3 times	Holding the front passenger's door handle or pressing the back door opener switch unlocks all the doors.
 Exterior: Beeps twice	Holding either front door handle or pressing the back door opener switch unlocks all the doors.

To prevent unintended triggering of the alarm, unlock the doors using the wireless remote control and open and close a door once after the settings have been changed. (If a door is not opened within 30 seconds after  is pressed, the doors will be locked again and the alarm will automatically be set.) In a case that the alarm is triggered, immediately stop the alarm. (→P.73)

Impact detection door lock release system

In the event that the vehicle is subject to a strong impact, all the doors are unlocked. Depending on the force of the impact or the type of accident, however, the system may not operate.

Operation signals

Doors: The emergency flashers flash to indicate that the doors have been locked/unlocked. (Locked: Once; Unlocked: Twice)

Side windows: A buzzer sounds to indicate that the side windows are operating.

Security feature

If a door is not opened within approximately 30 seconds after the vehicle is unlocked, the security feature automatically locks the vehicle again. (However, depending on the location of the electronic key, the key may be detected as being in the vehicle. In this case, vehicle may be unlocked.)

When the door cannot be locked by the lock sensor on the upper part of the door handle

If the door will not lock even when the topside sensor area is touched, try touching both the topside and underside sensor areas at the same time.

When gloves are being worn, remove the gloves.

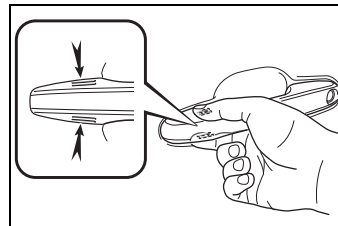

Door lock buzzer

A buzzer sounds continuously for 5 seconds in the following situations. Fully close all the doors and lock the vehicle once more.

- If an attempt to lock the doors using the smart entry & start system is made when a door other than the door you are locking is open.
- If an attempt to lock the doors using the wireless remote control is made when a door is open.

Setting the alarm

Locking the doors will set the alarm system. (→P.73)

■ **Conditions affecting the operation of the smart entry & start system or wireless remote control**

→P.208

■ **If the smart entry & start system or the wireless remote control does not operate properly**

- Use the mechanical key to lock and unlock the doors. (→P.533)
- Replace the key battery with a new one if it is depleted. (→P.484)

■ **If the 12-volt battery is discharged**

The doors cannot be locked and unlocked using the smart entry & start system or wireless remote control. Lock or unlock the doors using the mechanical key. (→P.533)

■ **Rear seat reminder function**

- In order to remind you not to forget luggage, etc. in the rear seat, when the power switch is turned to OFF after any of the following conditions are met, a buzzer will sound and a message will be displayed on the multi-information display for approximately 6 seconds.
 - The hybrid system is started within 10 minutes after opening and closing a rear door.
 - A rear door has been opened and closed after the hybrid system was started.

However, if a rear door is opened and then closed within approximately 2 seconds, the rear seat reminder function may not operate.

- The rear seat reminder function determines that luggage, etc. has been placed in a rear seat based on opening and closing of a rear door. Therefore, depending on the situation, the rear seat reminder function may not operate and you may still forget luggage, etc. in the rear seat, or it may operate unnecessarily.
- The rear seat reminder function can be enabled/disabled. (→P.559)

■ **Customization**

Settings (e.g. unlocking function using a key) can be changed.
(Customizable features: →P.558)

 **WARNING**

■ **To prevent an accident**

Observe the following precautions while driving the vehicle. Failure to do so may result in a door opening and an occupant could be thrown out of the vehicle, resulting in death or serious injury.

- Ensure that all doors are properly closed.
- Do not pull the inside handle of the doors while driving. Be especially careful for the front doors, as the doors may be opened even if the inside lock buttons are in locked position.
- Set the rear door child-protector locks when children are seated in the rear seats.

■ **When opening or closing a door**

Check the surroundings of the vehicle such as whether the vehicle is on an incline, whether there is enough space for a door to open and whether a strong wind is blowing. When opening or closing the door, hold the door handle tightly to prepare for any unpredictable movement.

■ **When using the wireless remote control or mechanical key and operating the power windows**

Operate the power window after checking to make sure that there is no possibility of any passenger having any of their body parts caught in the side window. Also, do not allow children to operate the wireless remote control or mechanical key. It is possible for children and other passengers to get caught in the side window.

Unlocking and locking the doors from the inside

■ **Using the door lock switches**

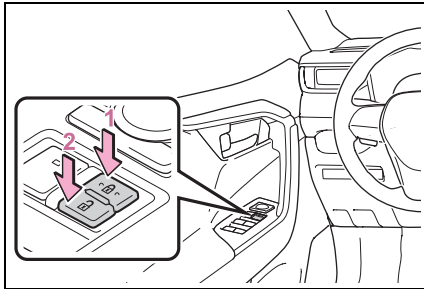

- 1 Locks all the doors
- 2 Unlocks all the doors

■ **Using the inside lock buttons**

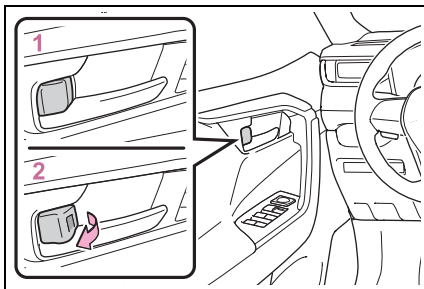

- 1 Locks the door
- 2 Unlocks the door

The front doors can be opened by pulling the inside handle even if the lock buttons are in the lock position.

■ **Locking the front doors from the outside without a key**

- 1 Move the inside lock button to the lock position.
- 2 Close the door while pulling the door handle.

The door cannot be locked if the power switch is in ACC or ON, or the electronic key is left inside the vehicle.

Depending on the position of the electronic key, the key may not be detected correctly and the door may be locked.

■ **Open door warning buzzer**

If the vehicle speed reaches 5 km/h (3 mph), a buzzer sounds to indicate that the door(s) or the hood is not fully closed.

The open door(s) or hood is displayed on the multi-information display.

■ **When all the doors are locked with the entry function or wireless remote control**

- The doors cannot be unlocked with the door lock switch.
- The door lock switches can be reset by unlocking all the doors with the entry function or wireless remote control.

Rear door child-protector lock

The door cannot be opened from inside the vehicle when the lock is set.

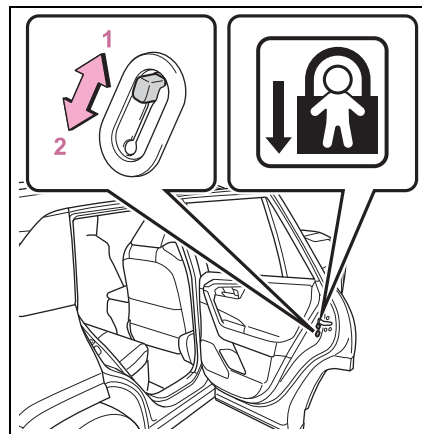

- 1 Unlock
- 2 Lock

These locks can be set to prevent chil-

dren from opening the rear doors. Push down on each rear door switch to lock both rear doors.

Automatic door locking and unlocking systems

The following functions can be set or canceled:

For instructions on customizing, refer to P.555.

Function	Operation
Speed linked door locking function	All doors are automatically locked when vehicle speed is approximately 20 km/h (12mph) or higher.
Shift position linked door locking function	All doors are automatically locked when shifting the shift lever to position other than P.
Shift position linked door unlocking function	All doors are automatically unlocked when shifting the shift lever to P.
Driver's door linked door unlocking function	All doors are automatically unlocked when driver's door is opened within approximately 45 seconds after turning the power switch off.

Back door

The back door can be locked/unlocked and opened/closed by the following procedures.

Charging port lid and charging connector will also be locked and unlocked. (→P.114)

WARNING

Observe the following precautions. Failure to do so may result in death or serious injury.

■ Before driving

- Make sure that the back door is fully closed.
If the back door is not fully closed, it may open unexpectedly while driving and hit near-by objects or luggage in the luggage compartment may be thrown out, causing an accident.
- Do not allow children to play in the luggage compartment.
If a child is accidentally locked in the luggage compartment, they could get heat exhaustion or other injuries.
- Do not allow a child to open or close the back door.
Doing so may cause the back door to operate unexpectedly, or cause the child's hands, head, or neck to be caught by the closing back door.

■ Important points while driving

- Keep the back door closed while driving.
If the back door is left open, it may hit near-by objects or luggage in the luggage compartment may be thrown out, causing an accident.

⚠ WARNING

- Never let anyone sit in the luggage compartment. In the event of sudden braking, sudden swerving or a collision, they are susceptible to death or serious injury.

■ **Back door handles**

Do not hang any object to the back door handles. If any object is hung, the back door may suddenly shut, causing parts of the body to be caught, resulting in death or serious injury.

■ **Operating the back door**

Observe the following precautions. Failure to do so may cause parts of the body to be caught, resulting in death or serious injury.

- Remove any heavy loads, such as snow and ice, from the back door before opening it. Failure to do so may cause the back door to suddenly shut again after it is opened.
- When opening or closing the back door, thoroughly check to make sure the surrounding area is safe.
- If anyone is in the vicinity, make sure they are safe and let them know that the back door is about to open or close.
- Use caution when opening or closing the back door in windy weather as it may move abruptly in strong wind.
- The back door may suddenly shut if it is not opened fully, while on a steep incline. Make sure that the back door is secured before using the luggage compartment.

- When closing the back door, take extra care to prevent your fingers, etc. from being caught.

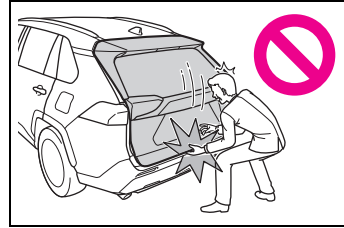

- Do not pull on the back door spindle (→P.204) to close the back door, and do not hang on the back door spindle. Doing so may cause hands to be caught or the back door spindle to break, causing an accident.

Unlocking and locking the back door from the outside

■ **Using the entry function**

Carry the electronic key to enable this function.

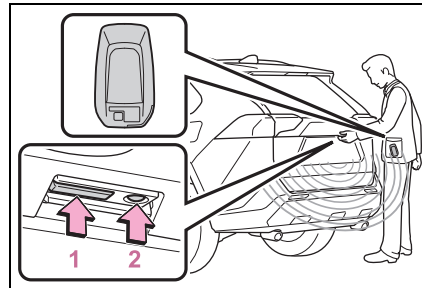

1 Unlocks all the doors

The doors cannot be unlocked for 3 seconds after the doors are locked.

2 Locks all the doors

Check that the door is securely locked.

■ **Using the wireless remote control**

→P.191

■ **Operation signals**

→P.192

■ **Security feature**

→P.192

Unlocking and locking the back door from the inside

■ **Using the door lock switches**

→P.194

Opening/closing the back door

■ **Using the wireless remote control**

Press and hold the switch.

The power back door automatically opens/closes.

Unlock the back door before operating.

Pressing the switch while the power back door is opening/closing stops the operation. When the switch is pressed and held again during the halted operation, the back door will perform the reverse operation.

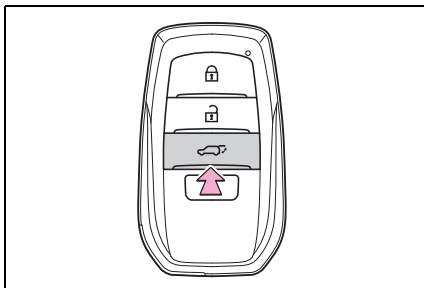

■ **Using the power back door switch on the instrument panel**

Press and hold the switch.

The power back door automatically opens/closes.

Unlock the back door before operating.

Pressing the switch while the power back door is opening/closing stops the operation. When the switch is pressed and held again during the halted operation, the back door will perform the reverse operation.

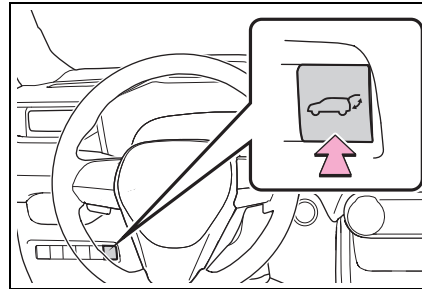

■ **Using the back door opener switch**

When the back door is unlocked:
Press the back door opener switch.

When the back door is locked:
While carrying the electronic key on your person, press and hold the back door opener switch.

The power back door automatically opens.

Pressing the switch while the power back door is opening/closing stops the operation.

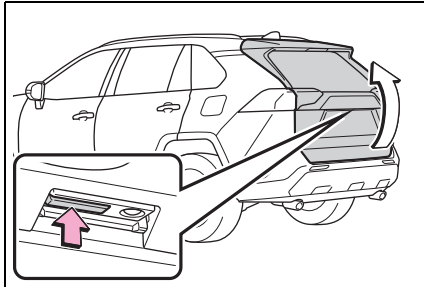

■ Using the power back door switch on the back door

Press the switch.

The power back door automatically closes.

Pressing the switch while the power back door is operating will stop the operation. When the switch is pressed again during the halted operation, the back door will perform the reverse operation.

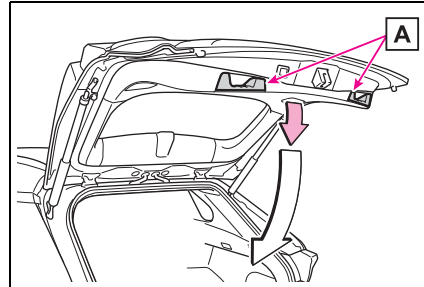

■ Using the kick sensor (Hands Free Power Back Door)

The Hands Free Power Back Door enables automatic opening and closing of the power back door by putting your foot near the lower center part of the rear bumper and moving it away from the rear bumper. When operating the Hands Free Power Back Door, make sure that the power switch is in OFF, the Hands Free Power Back Door operation is enabled (→P.177) and you are carrying an electronic key.

- 1 While carrying an electronic key, stand within the smart entry & start system operation range, approximately 30 to 50 cm (11.8 to 19.7 in.) from the rear bumper.

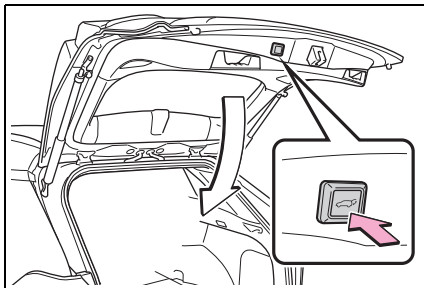

■ Using the back door handles

Lower the back door using the back door handle **A**.

The back door closing assist (→P.200) will be activated, and the power back door will fully close automatically.

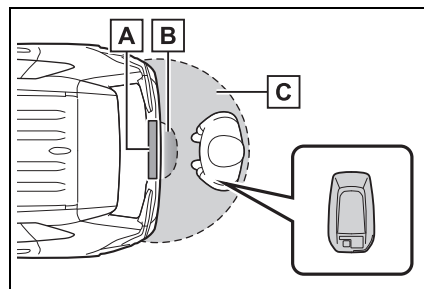

A Kick sensor

- B** Hands Free Power Back Door operation detection area
- C** Smart entry & start system operation detection area (→P.207)

- 2 Perform a kick operation by moving your foot to within approximately 10 cm (3.9 in.) of the rear bumper and then pulling it back.

Perform the entire kick operation within 1 second.

The back door will not start operating while a foot is detected under the rear bumper.

Operate the Hands Free Power Back Door without contacting the rear bumper with your foot.

If another electronic key is in the cabin or luggage compartment, it may take slightly longer than normal for the operation to occur.

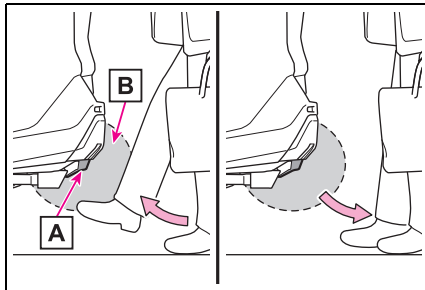

- A** Kick sensor
 - B** Hands Free Power Back Door operation detection area
- 3 When the kick sensor detects that your foot is pulled back, a buzzer will sound and the back door will automatically fully open/close.

If a foot is moved under the rear

bumper while the back door is opening/closing, the back door will stop moving.

If a foot is moved under the rear bumper again during the halted operation, the back door will perform the reverse operation.

■ Luggage compartment light

The luggage compartment light turns on when the back door is opened with the luggage compartment light switch on.

When the power switch is turned to OFF, the light will go off automatically after 20 minutes.

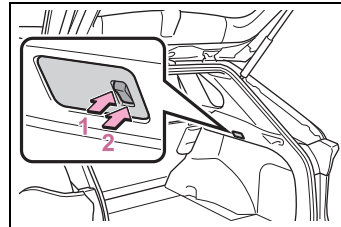

- 1 On
- 2 Off

■ Back door closer

In the event that the back door is left slightly open, the back door closer will automatically close it to the fully closed position.

Whatever the state of the power switch, the back door closer operates.

■ Power back door operating conditions

The power back door can automatically open and close under the following conditions:

- When the power back door system is enabled. (→P.177)

- When the back door is unlocked.

However, if the back door opener switch is pressed and held while carrying the electronic key on your person, the power back door will be operated even if the back door is locked. (→P.197)

- When the power switch is in ON, in addition to the above for the opening operations, the back door operates for any of the following conditions:
 - Parking brake is engaged
 - The brake pedal is depressed
 - The shift lever is in P.

■ **Operation of the power back door**

- A buzzer sounds to indicate that the back door is opening/closing.
- When the power back door system is disabled, the power back door does not operate but it can be opened and closed by hand.
- When the power back door automatically opens, if an abnormality due to people or objects is detected, operation will stop.

■ **Jam protection function**

Sensors are equipped on both sides of the power back door. If anything obstructs the power back door while it is closing, the back door will automatically operate in the opposite direction or stop.

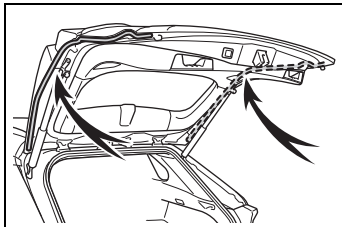

■ **Fall-down protection function**

While the power back door is opening automatically, applying excessive force to it will stop the opening operation to prevent the power back door from suddenly shutting.

■ **Back door closing assist**

If the back door is lowered manually when the back door is stopped at an open position, the back door will fully close automatically.

■ **Back door reserve lock function**

This function is a function which reserves locking of all doors, beforehand, when the power back door is

open.

When the following procedure is performed, all the doors except the power back door are locked and then power back door will also be locked at the same time it is closed.

- 1 Close all doors, except the back door.
- 2 During the power back door closing operation, lock the doors using the smart entry & start system from the front doors (→P.191) or the wireless remote control. (→P.191)

Operation signals will indicate that all the doors have been closed and locked. (→P.192)

- If the electronic key is placed inside the vehicle after starting a close operation via the door reserve lock function, the electronic key may become locked inside the vehicle.
- If the power back door does not fully close due to the operation of the jam protection function, etc., while the back door is automatically closing after a door reserve lock operation is performed, the door reserve lock function is canceled and all the doors will unlock.
- Before leaving the vehicle, make sure that all the doors are closed and locked.

■ **Hands Free Power Back Door operating conditions**

The Hands Free Power Back Door will open/close automatically when the following conditions are met:

- The Hands Free Power Back Door operation is enabled (→P.177)
- The power switch is in OFF.
- The electronic key is within the operational range. (→P.207)
- A foot is put near the lower center part of the rear bumper and moved away from the rear bumper.
The power back door may also be operated by putting a hand, an elbow, a knee, etc. near the lower center part

of the rear bumper and moving it away from the rear bumper. Make sure to hold it close enough to the center part of the rear bumper.

■ **Situations in which the Hands Free Power Back Door may not operate properly**

In the following situations, the Hands Free Power Back Door may not operate properly:

- When a foot remains under the rear bumper
- If the rear bumper is strongly hit with a foot or is touched for a while

If the rear bumper has been touched for a while, wait for a short time before attempting to operate the Hands Free Power Back Door again.

- When operated while a person is too close to the rear bumper
- When an external radio wave source interferes with the communication between the electronic key and the vehicle (→P.208)
- When charging from an external power source or connecting the charging cable
- When the vehicle is parked near an electrical noise source which affects the sensitivity of the Hands Free Power Back Door, such as a pay parking spot, gas station, electrically heated road, or fluorescent light
- When the vehicle is near a TV tower, electric power plant, radio station, large display, airport or other facility that generates strong radio waves or electrical noise
- When a large amount of water is applied to the rear bumper, such as when the vehicle is being washed or in heavy rain
- When mud, snow, ice, etc. is attached to the rear bumper
- When the vehicle has been parked for a while near objects that may move and contact the rear bumper, such as

plants

- When an accessory is installed to the rear bumper

If an accessory has been installed, turn the Hands Free Power Back Door operation setting off.

■ **Preventing unintentional operation of the Hands Free Power Back Door**

When an electronic key is in the operation range, the Hands Free Power Back Door may operate unintentionally, so be careful in the following situations.

- When a large amount of water is applied to the rear bumper, such as when the vehicle is being washed or in heavy rain
- When dirt is wiped off the rear bumper
- When a small animal or small object, such as a ball, moves under the rear bumper
- When an object is moved from under the rear bumper
- If someone is swinging their legs while sitting on the rear bumper
- If the legs or another part of someone's body contacts the rear bumper while passing by the vehicle
- When the vehicle is parked near an electrical noise source which affects the sensitivity of the Hands Free Power Back Door, such as a pay parking spot, gas station, electrically heated road, or fluorescent light
- When the vehicle is near a TV tower, electric power plant, radio station, large display, airport or other facility that generates strong radio waves or electrical noise
- When the vehicle is parked in a place where objects such as plants are near the rear bumper
- If luggage, etc. is set near the rear bumper
- If accessories or a vehicle cover is installed/removed near the rear bumper

202 4-2. Opening, closing and locking the doors

● When the vehicle is being towed
To prevent unintentional operation, turn the Hands Free Power Back Door operation setting off. (→P.177)

■ When reconnecting the 12-volt battery

To enable the power back door to operate properly, close the back door manually.

■ If the back door opener is inoperative

The back door can be unlocked from the inside.

1 Remove the cover.

To prevent damage, cover the tip of the screwdriver with a rag.

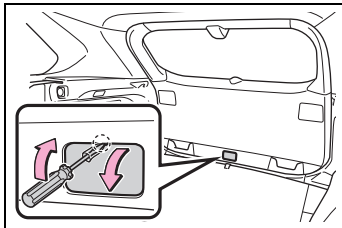

2 Loosen the screw.

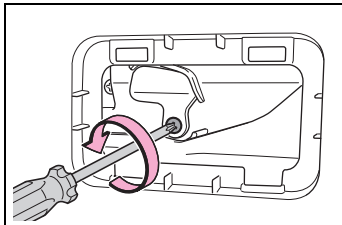

3 Turn the cover.

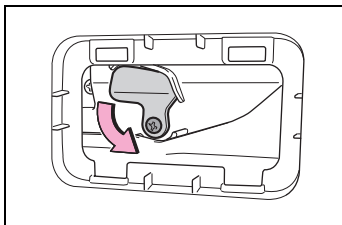

4 Move the lever.

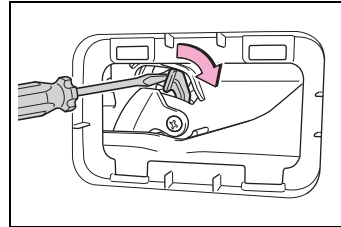

5 When installing, reverse the steps listed.

■ Customization

Settings (e.g. power back door opening angle) can be changed. (Customizable features: →P.560)

⚠ WARNING

■ Back door closer

● In the event that the back door is left slightly open, the back door closer will automatically close it to the fully closed position. It takes several seconds before the back door closer begins to operate. Be careful not to catch fingers or anything else in the back door, as this may cause bone fractures or other serious injuries.

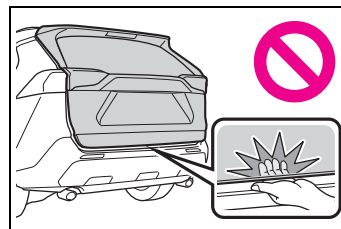

● Use caution when using the back door closer as it still operates when the power back door system is canceled.

**WARNING****Power back door**

Observe the following precautions when operating the power back door. Failure to do so may cause death or serious injury.

- Check the safety of the surrounding area to make sure there are no obstacles or anything that could cause any of your belongings to get caught.
- If anyone is in the vicinity, make sure they are safe and let them know that the back door is about to open or close.
- If the power back door system is turned off while the back door is operating automatically, the automatic operation is stopped. The back door then has to be operated manually. Take extra care when on an incline, as the back door may open or close unexpectedly.
- If the operating conditions of the power back door are no longer met, a buzzer may sound and the back door may stop opening or closing. The back door then has to be operated manually. Take extra care when on an incline, as the back door may open or close abruptly.
- On an incline, the back door may suddenly shut after it opens. Make sure the back door is fully open and secure.

- In the following situations, the power back door may detect an abnormality and automatic operation may be stopped. In this case, the back door has to be operated manually. Take extra care when on an incline, as the back door may open or close abruptly.
 - When the back door contacts an obstacle
 - When the 12-volt battery voltage suddenly drops, such as when the power switch is turned to ON or the hybrid system is started during automatic operation
- If a bicycle carrier or similar heavy object is attached to the back door, the power back door may not operate, causing itself to malfunction, or the back door may suddenly shut again after being opened, causing someone's hands, head or neck to be caught and injured. When installing an accessory part to the back door, using a genuine Suzuki part is recommended.

Jam protection function

Observe the following precautions. Failure to do so may cause death or serious injury.

- Never use any part of your body to intentionally activate the jam protection function.
- The jam protection function may not work if something gets caught just before the back door fully closes. Be careful not to catch fingers or anything else.
- The jam protection function may not work depending on the shape of the object that is caught. Be careful not to catch fingers or anything else.



WARNING

■ **Hands Free Power Back Door**

Observe the following precautions when operating the Hands Free Power Back Door. Failure to do so may cause death or serious injury.

- Check the safety of the surrounding area to make sure there are no obstacles or anything that could cause any of your belongings to get caught.
- When putting your foot near the lower center part of the rear bumper and moving it from the rear bumper, be careful not to touch the exhaust pipes until they have cooled down sufficiently, as touching hot exhaust pipes can cause burns.
- Do not leave the electronic key within the effective range (detection area) of the luggage compartment.



NOTICE

■ **Back door spindles**

The back door is equipped with spindles that hold the back door in place. Observe the following precautions. Failure to do so may cause damage to the back door spindle, resulting in malfunction.

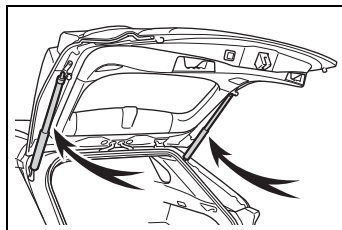

- Do not touch the spindle rod with gloves or other fabric items.
- Do not attach any accessories other than genuine Suzuki parts to the back door.

- Do not place your hand on the spindle or apply lateral forces to it.

■ **To prevent back door closer malfunction**

Do not apply excessive force to the back door while the back door closer is operating. Applying excessive force may cause the back door closer to malfunction.

■ **To prevent damage to the power back door**

- Make sure that there is no ice between the back door and frame that would prevent movement of the back door. Operating the power back door when excessive load is present on the back door may cause a malfunction.

- Do not apply excessive force to the back door while the power back door is operating.

- Take care not to damage the sensors (installed on the right and left edges of the power back door) with a knife or other sharp object. If the sensor is disconnected, the power back door will not close automatically.

■ **Hands Free Power Back Door precautions**

The kick sensor is located behind lower center part of the rear bumper. Observe the following to ensure that the Hands Free Power Back Door function operates properly:

- Keep the lower center part of the rear bumper clean at all times. If the lower center part of the rear bumper is dirty or covered with snow, the kick sensor may not operate. In this situation, clean off the dirt or snow, move the vehicle from the current position and then check if the kick sensor operates. If it does not operate, have the vehicle inspected by a SUZUKI dealer or a qualified workshop.

 NOTICE

- Do not apply coatings that have a rain clearing (hydrophilic) effect, or other coatings, to the lower center part of the rear bumper.
- Do not park the vehicle near objects that may move and contact the lower center part of the rear bumper, such as grass or trees. If the vehicle has been parked for a while near objects that may move and contact the lower center part of the rear bumper, such as grass or trees, the kick sensor may not operate. In this situation, move the vehicle from the current position and then check if the kick sensor operates. If it does not operate, have the vehicle inspected by a SUZUKI dealer or a qualified workshop.
- Do not subject the kick sensor or its surrounding area to a strong impact. If the kick sensor or its surrounding area has been subjected to a strong impact, the kick sensor may not operate properly. If the kick sensor does not operate in the following situations, have the vehicle inspected by a SUZUKI dealer or a qualified workshop.
 - The kick sensor or its surrounding area has been subjected to a strong impact.
 - The lower center part of the rear bumper is scratched or damaged.
- Do not disassemble the rear bumper.
- Do not attach stickers to the rear bumper.
- Do not paint the rear bumper.
- If a bicycle carrier or similar heavy object is attached to the power back door, disable the Hands Free Power Back Door. (→P.177)

Changing settings of the power back door system

The settings of the power back door system can be changed by selecting the “Vehicle Settings” from the  screen of the multi-information display and displaying the “PBD” screen. (→P.177)

The changed power back door settings are not reset by turning the power switch to OFF. In order to restore the original settings, they need to be changed back on the  screen of the multi-information display.

Adjusting the open position of the back door

The open position of the power back door can be adjusted.

- 1 Stop the back door in the desirable position. (→P.197)
- 2 Press and hold the power back door switch on the back door for approximately 2 seconds.

When the settings are completed, the buzzer sounds 4 times.

When opening the back door the next time, the back door will stop at that position.

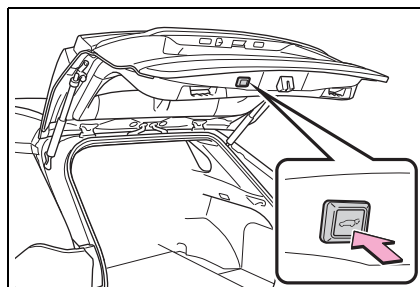

■ **Canceling the adjusted open position of the back door**

Press and hold the power back door switch on the back door for approximately 7 seconds.

After the buzzer sounds 4 times, it sounds twice more. When the power back door does the opening operation the next time, the door will open to the initial settings position.

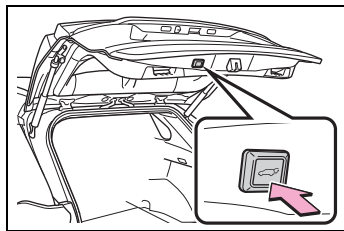

■ **Customization**

The opening position can be set with the multi-information display. (→P.177)

Priority for the stop position is given to the last position set by either the power back door switch on the back door or multi-information display.

Smart entry & start system

The following operations can be performed simply by carrying the electronic key on your person, for example in your pocket. The driver should always carry the electronic key.

- Locks and unlocks the doors* (→P.191)
- Locks and unlocks the back door* (→P.196)
- Starts the hybrid system (→P.279)

*: Charging port lid and charging connector will also be locked and unlocked. (→P.114)

■ **Antenna location**

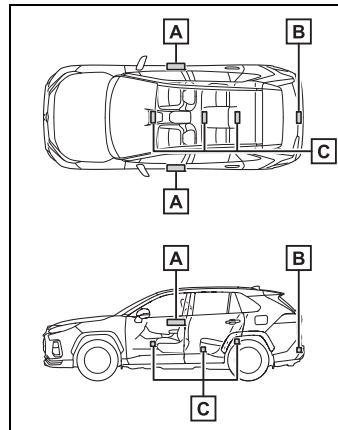

- A** Antennas outside the cabin
- B** Antenna outside the luggage compartment

C Antennas inside the cabin

Effective range (areas within which the electronic key is detected)

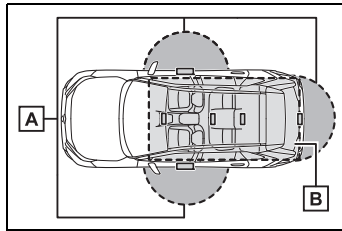

A When locking or unlocking the doors

The system can be operated when the electronic key is within about 0.7 m (2.3 ft.) of the front door handles, rear door handles (if equipped) and back door opener switch. (Only the doors detecting the key can be operated.)

B When starting the hybrid system or changing power switch modes

The system can be operated when the electronic key is inside the vehicle.

If an alarm sounds or a warning message is displayed

An alarm sounds and warning message displays shown on the multi-information display are used to protect against unexpected accidents or theft of the vehicle resulting from erroneous operation. When a warning message is displayed, take appropriate measures based on the displayed message.

When only an alarm sounds, circumstances and correction procedures are as follows.

- When an exterior alarm sounds once for 5 seconds

Situation	Correction procedure
An attempt was made to lock the vehicle while a door was open.	Close all of the doors and lock the doors again.

- When an interior alarm pings continuously

Situation	Correction procedure
The power switch was turned to ACC while the driver's door was open (or the driver's door was opened while the power switch was in ACC).	Turn the power switch to OFF and close the driver's door.



Battery-saving function

The battery-saving function will be activated in order to prevent the electronic key battery and the 12-volt battery from being discharged while the vehicle is not in operation for a long time.

- In the following situations, the smart entry & start system may take some time to unlock the doors.
 - The electronic key has been left in an area of approximately 3.5 m (11.5 ft.) of the outside of the vehicle for 2 minutes or longer.
 - The smart entry & start system has not been used for 5 days or longer.
- If the smart entry & start system has not been used for 14 days or longer, the doors cannot be unlocked at any doors except the driver's door. In this case, take hold of the driver's door handle, or use the wireless remote control or the mechanical key, to unlock the doors.

■ **Turning an electronic key to battery-saving mode**

- When battery-saving mode is set, battery depletion is minimized by stopping the electronic key from receiving radio waves.

Press  twice while pressing and holding .

Confirm that the electronic key indicator flashes 4 times.

While the battery-saving mode is set, the smart entry & start system cannot be used. To cancel the function, press any of the electronic key buttons.

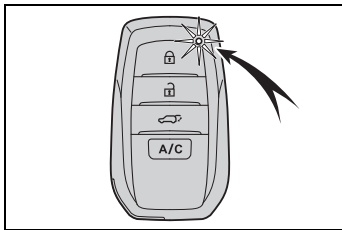

- Electronic keys that will not be used for long periods of time can be set to the battery-saving mode in advance.

■ **Conditions affecting operation**

The smart entry & start system uses weak radio waves. In the following situations, the communication between the electronic key and the vehicle may be affected, preventing the smart entry & start system, wireless remote control and immobilizer system from operating properly.

- When the electronic key battery is depleted
- Near a TV tower, electric power plant, gas station, radio station, large display, airport or other facility that generates strong radio waves or electrical noise
- When the electronic key is in contact with, or is covered by the following metallic objects
 - Cards to which aluminum foil is attached

- Cigarette boxes that have aluminum foil inside
- Metallic wallets or bags
- Coins
- Hand warmers made of metal
- Media such as CDs and DVDs

- When other wireless key (that emits radio waves) is being used nearby
- When carrying the electronic key together with the following devices that emit radio waves
 - Portable radio, cellular phone, cordless phone or other wireless communication devices
 - Another vehicle's electronic key or a wireless key that emits radio waves
 - Personal computers or personal digital assistants (PDAs)
 - Digital audio players
 - Portable game systems

- If window tint with a metallic content or metallic objects are attached to the rear window
- When the electronic key is placed near a battery charger or electronic devices
- When the vehicle is parked in a pay parking spot where radio waves are emitted.

If the doors cannot be locked/unlocked using the smart entry & start system, lock/unlock the doors by performing any of the following:

- Bring the electronic key close to either front door handle and operate the entry function.
- Operate the wireless remote control. If the doors cannot be locked/unlocked using the above methods, use the mechanical key. (→P.190)

If the hybrid system cannot be started using the smart entry & start system, refer to P.534.

■ **Note for the entry function**

- Even when the electronic key is within the effective range (detection areas), the system may not operate properly in the following cases:

- The electronic key is too close to the window or outside door handle, near the ground, or in a high place when the doors are locked or unlocked.
 - The electronic key is on the instrument panel, luggage cover or floor, or in the door pockets or glove box when the hybrid system is started or power switch modes are changed.
 - Do not leave the electronic key on top of the instrument panel or near the door pockets when exiting the vehicle. Depending on the radio wave reception conditions, it may be detected by the antenna outside the cabin and the door will become lockable from the outside, possibly trapping the electronic key inside the vehicle.
 - As long as the electronic key is within the effective range, the doors may be locked or unlocked by anyone. However, only the doors detecting the electronic key can be used to lock or unlock the vehicle.
 - Even if the electronic key is not inside the vehicle, it may be possible to start the hybrid system if the electronic key is near the window.
 - The doors may unlock if a large amount of water splashes on the door handle, such as in the rain or in a car wash when the electronic key is within the effective range. (The doors will automatically be locked after approximately 30 seconds if the doors are not opened and closed.)
 - If the wireless remote control is used to lock the doors when the electronic key is near the vehicle, there is a possibility that the door may not be unlocked by the entry function. (Use the wireless remote control to unlock the doors.)
 - Touching the door lock sensor while wearing gloves may delay or prevent lock operation. Remove the gloves and touch the lock sensor again.
 - When the lock operation is performed using the lock sensor, recognition signals will be shown up to two consecutive times. After this, no recognition signals will be given.
 - If the door handle becomes wet while the electronic key is within the effective range, the door may lock and unlock repeatedly. In that case, follow the following correction procedures to wash the vehicle:
 - Place the electronic key in a location 2 m (6 ft.) or more away from the vehicle. (Take care to ensure that the key is not stolen.)
 - Set the electronic key to battery-saving mode to disable the smart entry & start system. (→P.208)
 - If the electronic key is inside the vehicle and a door handle becomes wet during a car wash, a message may be shown on the multi-information display and a buzzer will sound outside the vehicle. To turn off the alarm, lock all the doors.
 - The lock sensor may not work properly if it comes into contact with ice, snow, mud, etc. Clean the lock sensor and attempt to operate it again, or use the lock sensor on the lower part of the door handle.
 - A sudden approach to the effective range or door handle may prevent the doors from being unlocked. In this case, return the door handle to the original position and check that the doors unlock before pulling the door handle again.
 - If there is another electronic key in the detection area, it may take slightly longer to unlock the doors after the door handle is gripped.
- **When the vehicle is not driven for extended periods**
- To prevent theft of the vehicle, do not leave the electronic key within 2 m (6 ft.) of the vehicle.
 - The smart entry & start system can be deactivated in advance. (→P.558)
 - Battery-saving mode can reduce the power consumption of electronic keys. (→P.208)

■ **To operate the system properly**

Make sure to carry the electronic key when operating the system. For vehicles with entry function, do not get the electronic key too close to the vehicle when operating the system from the outside of the vehicle.

Depending on the position and holding condition of the electronic key, the key may not be detected correctly and the system may not operate properly. (The alarm may go off accidentally, or the door lock prevention may not operate.)

■ **If the smart entry & start system does not operate properly**

- Locking and unlocking the doors: Use the mechanical key. (→P.533)
- Starting the hybrid system: →P.279

■ **Customization**

Settings (e.g. smart entry & start system) can be changed.
(Customizable features: →P.558)

If the smart entry & start system has been deactivated in a customized setting, refer to the explanations for the following operations.

- Locking and unlocking the doors:
Use the wireless remote control or mechanical key. (→P.191, 533)
- Starting the hybrid system and changing power switch modes: →P.534
- Stopping the hybrid system: →P.281

■ Certification for the smart entry & start system

<p>Transmitter: Model: TMLF19D-1 Operation frequency: 134.2kHz Maximum output power (ERP): 0.41mW Manufacturer: TOYOTA MOTOR CORPORATION Address: 1, Toyota-Cho, Toyota, Aichi, 471-8572, Japan</p>	00 91
<p>Hereby, TOYOTA MOTOR CORPORATION declares that the radio equipment type is in compliance with Directive 2014/53/EU. The full text of the EU declaration of conformity is available at the following internet address: https://www.denso.com/global/en/contact-us/doc/</p>	01 91
<p>TOYOTA MOTOR CORPORATION vakuuttaa, että radiolaitetyyppi on direktiivin 2014/53/EU mukainen. EU-vaatimustenmukaisuusvakuutuksen täysimittainen teksti on saatavilla seuraavassa internetosoitteessa: https://www.denso.com/global/en/contact-us/doc/</p>	02 91
<p>Hierbij verklaar ik, TOYOTA MOTOR CORPORATION, dat het type radioapparatuur conform is met Richtlijn 2014/53/EU. De volledige tekst van de EU-conformiteitsverklaring kan worden geraadpleegd op het volgende internetadres: https://www.denso.com/global/en/contact-us/doc/</p>	03 91
<p>Le soussigné, TOYOTA MOTOR CORPORATION, déclare que l'équipement radioélectrique du type est conforme à la directive 2014/53/UE. Le texte complet de la déclaration UE de conformité est disponible à l'adresse internet suivante: https://www.denso.com/global/en/contact-us/doc/</p>	04 91
<p>Härmed försäkrar TOYOTA MOTOR CORPORATION att denna typ av radioutrustning överensstämmer med direktiv 2014/53/EU. Den fullständiga texten till EU-försäkran om överensstämmelse finns på följande webbadress: https://www.denso.com/global/en/contact-us/doc/</p>	05 91

<p>Hermed erklærer TOYOTA MOTOR CORPORATION, at radioudstyrstypen er i overensstemmelse med direktiv 2014/53/EU. EU-overensstemmelseserklæringens fulde tekst kan findes på følgende internetadresse: https://www.denso.com/global/en/contact-us/doc/</p>	06 91
<p>Hiermit erklärt TOYOTA MOTOR CORPORATION, dass der Funkanlagentyp der Richtlinie 2014/53/EU entspricht. Der vollständige Text der EU-Konformitätserklärung ist unter der folgenden Internetadresse verfügbar: https://www.denso.com/global/en/contact-us/doc/</p>	07 91
<p>Με την παρούσα ο/η TOYOTA MOTOR CORPORATION, δηλώνει ότι ο ραδιοεξοπλισμός πληροί την οδηγία 2014/53/ΕΕ. Το πλήρες κείμενο της δήλωσης συμμόρφωσης ΕΕ διατίθεται στην ακόλουθη ιστοσελίδα στο διαδίκτυο: https://www.denso.com/global/en/contact-us/doc/</p>	08 91
<p>Il fabbricante, TOYOTA MOTOR CORPORATION, dichiara che il tipo di apparecchiatura radio è conforme alla direttiva 2014/53/UE. Il testo completo della dichiarazione di conformità UE è disponibile al seguente indirizzo Internet: https://www.denso.com/global/en/contact-us/doc/</p>	09 91
<p>Por la presente, TOYOTA MOTOR CORPORATION declara que el tipo de equipo radioeléctrico es conforme con la Directiva 2014/53/UE. El texto completo de la declaración UE de conformidad está disponible en la dirección Internet siguiente: https://www.denso.com/global/en/contact-us/doc/</p>	10 91
<p>O(a) abaixo assinado(a) TOYOTA MOTOR CORPORATION declara que o presente tipo de equipamento de rádio está em conformidade com a Diretiva 2014/53/UE. O texto integral da declaração de conformidade está disponível no seguinte endereço de Internet: https://www.denso.com/global/en/contact-us/doc/</p>	11 91

B'dan, TOYOTA MOTOR CORPORATION, niddikjara li dan it-tip ta' tagħmir tar-radju huwa konformi mad-Direttiva 2014/53/UE. It-test kollu tad-dikjarazzjoni ta' konformità tal-UE huwa disponibbli f'dan l-indirizz tal-Internet li ġej: https://www.denso.com/global/en/contact-us/doc/	12 91
Käesolevaga deklareerib TOYOTA MOTOR CORPORATION, et käesolev raadioseadme tüüp vastab direktiivi 2014/53/EL nõuetele. ELi vastavusdeklaratsiooni täielik tekst on kättesaadav järgmisel internetiaadressil: https://www.denso.com/global/en/contact-us/doc/	13 91
TOYOTA MOTOR CORPORATION igazolja, hogy a típusú rádióberendezés megfelel a 2014/53/EU irányelvnek. Az EU-megfelelőségi nyilatkozat teljes szövege elérhető a következő internetes címen: https://www.denso.com/global/en/contact-us/doc/	14 91
TOYOTA MOTOR CORPORATION týmto vyhlasuje, že rádiové zariadenie typu je v súlade so smernicou 2014/53/EÚ. Úplné EÚ vyhlásenie o zhode je k dispozícii na tejto internetovej adrese: https://www.denso.com/global/en/contact-us/doc/	15 91
Tímto TOYOTA MOTOR CORPORATION prohlašuje, že typ rádiového zařízení je v souladu se směrnicí 2014/53/EU. Úplné znění EU prohlášení o shodě je k dispozici na této internetové adrese: https://www.denso.com/global/en/contact-us/doc/	16 91
TOYOTA MOTOR CORPORATION potvrjuje, da je tip radijske opreme skladen z Direktivo 2014/53/EU. Celotno besedilo izjave EU o skladnosti je na voljo na naslednjem spletnem naslovu: https://www.denso.com/global/en/contact-us/doc/	17 91

<p>Aš, TOYOTA MOTOR CORPORATION, patvirtinu, kad radijo įrenginių tipas atitinka Direktyvą 2014/53/ES. Visas ES atitikties deklaracijos tekstas prieinamas šiuo interneto adresu: https://www.denso.com/global/en/contact-us/doc/</p>	18
<p>Ar šo TOYOTA MOTOR CORPORATION deklarė, ka radioiekārta atbilst Direktīvai 2014/53/ES. Pilns ES atbilstības deklarācijas teksts ir pieejams šādā interneta vietnē: https://www.denso.com/global/en/contact-us/doc/</p>	19
<p>TOYOTA MOTOR CORPORATION niniejszym oświadcza, że typ urządzenia radiowego jest zgodny z dyrektywą 2014/53/UE. Pełny tekst deklaracji zgodności UE jest dostępny pod następującym adresem internetowym: https://www.denso.com/global/en/contact-us/doc/</p>	20
<p>Hér með lýsir TOYOTA MOTOR CORPORATION yfir því að er í samræmi við grunnkröfur og aðrar kröfur, sem gerðar eru í tilskipun 2014/53/EU. Samræmisýfirlýsing er einnig aðgengileg á eftirfarandi vefslóð: https://www.denso.com/global/en/contact-us/doc/</p>	21
<p>TOYOTA MOTOR CORPORATION erklærer at er i overensstemmelse med direktiv 2014/53/EU. Samsvarserklæringen i fulltekst er tilgjengelig på følgende internettadresse: https://www.denso.com/global/en/contact-us/doc/</p>	22
<p>С настоящото TOYOTA MOTOR CORPORATION декларира, че този тип радиосъоръжение е в съответствие с Директива 2014/53/ЕС. Цялостният текст на ЕС декларацията за съответствие може да се намери на следния интернет адрес: https://www.denso.com/global/en/contact-us/doc/</p>	23

Prin prezenta, TOYOTA MOTOR CORPORATION declară că tipul de echipamente radio este în conformitate cu Directiva 2014/53/UE. Textul integral al declarației UE de conformitate este disponibil la următoarea adresă internet: https://www.denso.com/global/en/contact-us/doc/	24 91
TOYOTA MOTOR CORPORATION ovime izjavljuje da je radijska oprema tipa u skladu s Direktivom 2014/53/EU. Cjeloviti tekst EU izjave o sukladnosti dostupan je na sljedećoj internetskoj adresi: https://www.denso.com/global/en/contact-us/doc/	25 91
Овиме, DENSO CORPORATION изјављује да је радио опрема тип усаглашена са Директивом 2014/53/EU. Цео текст ЕУ декларације о усаглашености доступан је на следећој интернет адреси: https://www.denso.com/global/en/contact-us/doc/	26 91
Amb aquest document, DENSO CORPORATION declara que el tipus d'equipament radioelèctric es conforme a la Directiva 2014/53/UE. El text complet de la declaració UE de conformitat està disponible en la següent adreça d'Internet: https://www.denso.com/global/en/contact-us/doc/	27 91
İşbu belge; DENSO CORPORATION telsiz ekipmanı tipinin 2014/53/AB sayılı Direktif'e uygun olduğunu beyan eder. AB uygunluk beyanının tam metni aşağıdaki internet adresinde mevcuttur: https://www.denso.com/global/en/contact-us/doc/	28 91
Nepermjet kesaj, TOYOTA MOTOR CORPORATION, deklaroj qe ky TMLF19D-1 eshte ne pajtim me kerkesat thelbesore dhe dispozitat e tjera perkatese te Direktives 1999/5/EC.	29 91
 The latest "DECLARATION of CONFORMITY" (DoC) is available at the following address: https://www.denso.com/global/en/contact-us/doc/	30 91

Hereby, TOKAI RIKA CO., LTD. declares that the radio equipment type BH2KV is in compliance with Directive 2014/53/EU.

The full text of the EU declaration of conformity is available at the following internet address:

<http://www.tokai-rika.co.jp/pc>

TOKAI RIKA CO., LTD. vakuuttaa, että radiolaitetyyppi BH2KV on direktiivin 2014/53/EU mukainen.

EU-vaatimustenmukaisuusvakuutuksen täysimittainen teksti on saatavilla seuraavassa internetosoitteessa:

<http://www.tokai-rika.co.jp/pc>

Hierbij verklaar ik, TOKAI RIKA CO., LTD., dat het type radioapparatuur BH2KV conform is met Richtlijn 2014/53/EU.

De volledige tekst van de EU-conformiteitsverklaring kan worden geraadpleegd op het volgende internetadres:

<http://www.tokai-rika.co.jp/pc>

Le soussigné, TOKAI RIKA CO., LTD., déclare que l'équipement radioélectrique du type BH2KV est conforme à la directive 2014/53/UE.

Le texte complet de la déclaration UE de conformité est disponible à l'adresse internet suivante:

<http://www.tokai-rika.co.jp/pc>

Härmed försäkrar TOKAI RIKA CO., LTD. att denna typ av radioutrustning BH2KV överensstämmer med direktiv 2014/53/EU.

Den fullständiga texten till EU-försäkran om överensstämmelse finns på följande webbadress:

<http://www.tokai-rika.co.jp/pc>

Herved erklærer TOKAI RIKA CO., LTD., at radioudstyrstypen BH2KV er i overensstemmelse med direktiv 2014/53/EU.

EU-overensstemmelseserklæringens fulde tekst kan findes på følgende internetadresse:

<http://www.tokai-rika.co.jp/pc>

Hiermit erklärt TOKAI RIKA CO., LTD., dass der Funkanlagentyp BH2KV der Richtlinie 2014/53/EU entspricht.

Der vollständige Text der EU-Konformitätserklärung ist unter der folgenden Internetadresse verfügbar:

<http://www.tokai-rika.co.jp/pc>

Με την παρούσα ο/η TOKAI RIKA CO., LTD., δηλώνει ότι ο ραδιοεξοπλισμός BH2KV πληροί την οδηγία 2014/53/ΕΕ.

Το πλήρες κείμενο της δήλωσης συμμόρφωσης ΕΕ διατίθεται στην ακόλουθη ιστοσελίδα στο διαδίκτυο:

<http://www.tokai-rika.co.jp/pc>

Il fabbricante, TOKAI RIKA CO., LTD., dichiara che il tipo di apparecchiatura radio BH2KV è conforme alla direttiva 2014/53/UE.

Il testo completo della dichiarazione di conformità UE è disponibile al seguente indirizzo Internet:

<http://www.tokai-rika.co.jp/pc>

Por la presente, TOKAI RIKA CO., LTD. declara que el tipo de equipo radioeléctrico BH2KV es conforme con la Directiva 2014/53/UE.

El texto completo de la declaración UE de conformidad está disponible en la dirección Internet siguiente:

<http://www.tokai-rika.co.jp/pc>

O(a) abaixo assinado(a) TOKAI RIKA CO., LTD. declara que o presente tipo de equipamento de rádio BH2KV está em conformidade com a Diretiva 2014/53/UE.

O texto integral da declaração de conformidade está disponível no seguinte endereço de Internet:

<http://www.tokai-rika.co.jp/pc>

B'dan, TOKAI RIKA CO., LTD., niddikjara li dan it-tip ta' tagħmir tar-radju BH2KV huwa konformi mad-Direttiva 2014/53/UE.

It-test kollu tad-dikjarazzjoni ta' konformità tal-UE huwa disponibbli f'dan l-indirizz tal-Internet li ġej:

<http://www.tokai-rika.co.jp/pc>

Käesolevaga deklareerib TOKAI RIKA CO., LTD., et käesolev raadioseadme tüüp BH2KV vastab direktiivi 2014/53/EL nõuetele.

ELi vastavusdeklaratsiooni täielik tekst on kättesaadav järgmisel internetiaadressil:
<http://www.tokai-rika.co.jp/pc>

TOKAI RIKA CO., LTD. igazolja, hogy a BH2KV típusú rádióberendezés megfelel a 2014/53/EU irányelvnek.

Az EU-megfelelőségi nyilatkozat teljes szövege elérhető a következő internetes címen:
<http://www.tokai-rika.co.jp/pc>

TOKAI RIKA CO., LTD. týmto vyhlasuje, že rádiové zariadenie typu BH2KV je v súlade so smernicou 2014/53/EÚ.

Úplné EÚ vyhlásenie o zhode je k dispozícii na tejto internetovej adrese:
<http://www.tokai-rika.co.jp/pc>

Tímto TOKAI RIKA CO., LTD. prohlašuje, že typ rádiového zařízení BH2KV je v souladu se směrnicí 2014/53/EU.

Úplné znění EU prohlášení o shodě je k dispozici na této internetové adrese:
<http://www.tokai-rika.co.jp/pc>

TOKAI RIKA CO., LTD. potvrdjuje, da je tip radijske opreme BH2KV skladen z Direktivo 2014/53/EU.

Celotno besedilo izjave EU o skladnosti je na voljo na naslednjem spletnem naslovu:

<http://www.tokai-rika.co.jp/pc>

Aš, TOKAI RIKA CO., LTD., patvirtinu, kad radijo įrenginių tipas BH2KV atitinka Direktyvą 2014/53/ES.

Visas ES atitikties deklaracijos tekstas prieinamas šiuo interneto adresu:

<http://www.tokai-rika.co.jp/pc>

Ar šo TOKAI RIKA CO., LTD. deklarė, ka radioiekārta BH2KV atbilst Direktīvai 2014/53/ES.

Pilns ES atbilstības deklarācijas teksts ir pieejams šādā interneta vietnē:

<http://www.tokai-rika.co.jp/pc>

TOKAI RIKA CO., LTD. niniejszym oświadcza, że typ urządzenia radiowego BH2KV jest zgodny z dyrektywą 2014/53/UE.

Pełny tekst deklaracji zgodności UE jest dostępny pod następującym adresem internetowym:

<http://www.tokai-rika.co.jp/pc>

TOKAI RIKA CO., LTD. lýsir því hér með yfir að fjarskiptatækið af gerð BH2KV er í samræmi við tilskipun 2014/53/EU.

Öll ESB-samræmisfirlýsingin er tiltæk á eftirfarandi vefslóð:
<http://www.tokai-rika.co.jp/pc>

TOKAI RIKA CO., LTD. erklærer herved at radioutstyrten BH2KV er i samsvar med direktivet 2014/53/EU.

Hele teksten av EU-samsvarserklæringen kan leses på det følgende nettstedet:
<http://www.tokai-rika.co.jp/pc>

С настоящото TOKAI RIKA CO., LTD. декларира, че този тип радиосъоръжение BH2KV е в съответствие с Директива 2014/53/ЕС.

Цялостният текст на ЕС декларацията за съответствие може да се намери на следния интернет адрес:
<http://www.tokai-rika.co.jp/pc>

Prin prezenta, TOKAI RIKA CO., LTD. declară că tipul de echipamente radio BH2KV este în conformitate cu Directiva 2014/53/UE.

Textul integral al declarației UE de conformitate este disponibil la următoarea adresă internet:
<http://www.tokai-rika.co.jp/pc>

Ovime TOKAI RIKA CO., LTD. potvrđuje da je radio-oprema tipa BH2KV u skladu sa Direktivom 2014/53/EU.

Potpuni tekst EU deklaracije o usaglašenosti dostupan je na slijedećoj internet adresi:

<http://www.tokai-rika.co.jp/pc>

Me anë të këtij dokumenti, TOKAI RIKA CO., LTD. deklararon se tipi i radiopajisjes BH2KV është në përputhje me Direktivën 2014/53/EU.

Teksti i plotë i deklaratës së konformitetit të Bashkimit Evropian është i disponueshëm në adresën e mëposhtme të internetit:

<http://www.tokai-rika.co.jp/pc>

TOKAI RIKA CO., LTD. ovime izjavljuje da je radijska oprema tipa BH2KV u skladu s Direktivom 2014/53/EU.

Cjeloviti tekst EU izjave o sukladnosti dostupan je na sljedećoj internetskoj adresi:

<http://www.tokai-rika.co.jp/pc>

Ovim TOKAI RIKA CO., LTD. potvrđuje da je radio-oprema tipa BH2KV u skladu sa Direktivom 2014/53/EU.

Potpuni tekst EU deklaracije o usaglašenosti dostupan je na sledećoj internet adresi:

<http://www.tokai-rika.co.jp/pc>

TOKAI RIKKA CO., LTD., işbu belgeyle telsiz cihazı türünün BH2KV 2014/53/EU nolu Direktif ile uyumlu olduğunu beyan etmektedir.

AB uygunluk beyanının tam metnine aşağıdaki internet adresinden ulaşabilirsiniz:

<http://www.tokai-rika.co.jp/pc>



Address: 3-260 Toyota, Oguchi-cho, Niwa-gun, Aichi 480-0195, Japan

Receiver Category (EN300 220): 2

Hereby, TOKAI RIKA CO., LTD. declares that the radio equipment type B3N2K2R is in compliance with Directive 2014/53/EU.

The full text of the EU declaration of conformity is available at the following internet address:

<http://www.tokai-rika.co.jp/pc>

Frequency band: 433.050 - 434.790 MHz
Maximum radio-frequency power: 10mW(ERP)

TOKAI RIKA CO., LTD. vakuuttaa, että radiolaitetyyppi B3N2K2R on direktiivin 2014/53/EU mukainen.

EU-vaatimustenmukaisuusvakuutuksen täysimittainen teksti on saatavilla seuraavassa internetosoitteessa:

<http://www.tokai-rika.co.jp/pc>

Radiotaajuus: 433.050 - 434.790 MHz
suurin mahdollinen lähetysteho: 10mW(ERP)

Hierbij verklaar ik, TOKAI RIKA CO., LTD., dat het type radioapparatuur B3N2K2R conform is met Richtlijn 2014/53/EU.

De volledige tekst van de EU-conformiteitsverklaring kan worden geraadpleegd op het volgende internetadres:

<http://www.tokai-rika.co.jp/pc>

Frequentieband: 433.050 - 434.790 MHz

Maximaal radiofrequentievermogen: 10mW(ERP)

Le soussigné, TOKAI RIKA CO., LTD., déclare que l'équipement radioélectrique du type B3N2K2R est conforme à la directive 2014/53/UE.

Le texte complet de la déclaration UE de conformité est disponible à l'adresse internet suivante:

<http://www.tokai-rika.co.jp/pc>

Bande de fréquences: 433.050 - 434.790 MHz

Puissance de radiofréquence maximale: 10mW(ERP)

Härmed försäkrar TOKAI RIKA CO., LTD. att denna typ av radioutrustning B3N2K2R överensstämmer med direktiv 2014/53/EU.

Den fullständiga texten till EU-försäkran om överensstämmelse finns på följande webbadress:

<http://www.tokai-rika.co.jp/pc>

Frekvensband: 433.050 - 434.790 MHz

Maximal radiofrekvensseffekt: 10mW(ERP)

Hermed erklærer TOKAI RIKA CO., LTD., at radioudstyrstypen B3N2K2R er i overensstemmelse med direktiv 2014/53/EU.

EU-overensstemmelseserklæringens fulde tekst kan findes på følgende internetadresse:

<http://www.tokai-rika.co.jp/pc>

Frekvensbånd: 433.050 - 434.790 MHz
Maksimal radiofrekvenseffekt: 10mW(ERP)

Hiermit erklärt TOKAI RIKA CO., LTD., dass der Funkanlagentyp B3N2K2R der Richtlinie 2014/53/EU entspricht.

Der vollständige Text der EU-Konformitätserklärung ist unter der folgenden Internetadresse verfügbar:

<http://www.tokai-rika.co.jp/pc>

Frequenzband: 433.050 - 434.790 MHz
Abgestrahlte maximale Sendeleistung: 10mW(ERP)

Με την παρούσα ο/η TOKAI RIKA CO., LTD., δηλώνει ότι ο ραδιοεξοπλισμός B3N2K2R πληροί την οδηγία 2014/53/ΕΕ.

Το πλήρες κείμενο της δήλωσης συμμόρφωσης ΕΕ διατίθεται στην ακόλουθη ιστοσελίδα στο διαδίκτυο:

<http://www.tokai-rika.co.jp/pc>

Ζώνη συχνοτήτων: 433.050 - 434.790 MHz
Μέγιστη ισχύς ραδιοσυχνότητας: 10mW(ERP)

Il fabbricante, TOKAI RIKA CO., LTD., dichiara che il tipo di apparecchiatura radio B3N2K2R è conforme alla direttiva 2014/53/UE.

Il testo completo della dichiarazione di conformità UE è disponibile al seguente indirizzo Internet:

<http://www.tokai-rika.co.jp/pc>

Banda di frequenza: 433.050 - 434.790 MHz
Potenza massima radiofrequenza: 10mW(ERP)

Por la presente, TOKAI RIKA CO., LTD. declara que el tipo de equipo radioeléctrico B3N2K2R es conforme con la Directiva 2014/53/UE.

El texto completo de la declaración UE de conformidad está disponible en la dirección Internet siguiente:

<http://www.tokai-rika.co.jp/pc>

Banda de frecuencia: 433.050 - 434.790 MHz
Potencia máxima de radiofrecuencia: 10mW(ERP)

O(a) abaixo assinado(a) TOKAI RIKA CO., LTD. declara que o presente tipo de equipamento de rádio B3N2K2R está em conformidade com a Diretiva 2014/53/UE.

O texto integral da declaração de conformidade está disponível no seguinte endereço de Internet:

<http://www.tokai-rika.co.jp/pc>

Banda de frequência: 433.050 - 434.790 MHz
Potência máxima de radiofrequências: 10mW(ERP)

B'dan, TOKAI RIKA CO., LTD., niddikjara li dan it-tip ta' tagħmir tar-radju B3N2K2R huwa konformi mad-Direttiva 2014/53/UE.

It-test kollu tad-dikjarazzjoni ta' konformità tal-UE huwa disponibbli f'dan l-indirizz tal-Internet li ġej:

<http://www.tokai-rika.co.jp/pc>

Tiċnisvið: 433.050 - 434.790 MHz
Hámarks útvarpsbylgjutíðni: 10mW(ERP)

Käesolevaga deklareerib TOKAI RIKA CO., LTD., et käesolev raadioseadme tüüp B3N2K2R vastab direktiivi 2014/53/EL nõuetele.

ELi vastavusdeklaratsiooni täielik tekst on kättesaadav järgmisel internetiaadressil:

<http://www.tokai-rika.co.jp/pc>

Sagedusriba: 433.050 - 434.790 MHz
Maksimaalne saatevõimsus: 10mW(ERP)

TOKAI RIKA CO., LTD. igazolja, hogy a B3N2K2R típusú rádióberendezés megfelel a 2014/53/EU irányelvnek.

Az EU-megfelelőségi nyilatkozat teljes szövege elérhető a következő internetes címen:

<http://www.tokai-rika.co.jp/pc>

Frekvenciasáv: 433.050 - 434.790 MHz
Maximális jelerősség: 10mW(ERP)

TOKAI RIKA CO., LTD. týmto vyhlasuje, že rádiové zariadenie typu B3N2K2R je v súlade so smernicou 2014/53/EÚ.

Úplné EÚ vyhlásenie o zhode je k dispozícii na tejto internetovej adrese:

<http://www.tokai-rika.co.jp/pc>

Frekvenčné pásmo: 433.050 - 434.790 MHz
Maximálny rádiový výkon: 10mW(ERP)

Tímto TOKAI RIKA CO., LTD. prohlašuje, že typ rádiového zařízení B3N2K2R je v souladu se směrnicí 2014/53/EU.

Úplné znění EU prohlášení o shodě je k dispozici na této internetové adrese:

<http://www.tokai-rika.co.jp/pc>

Kmitočtové pásmo: 433.050 - 434.790 MHz
Maximální radiofrekvenční výkon: 10mW(ERP)

TOKAI RIKA CO., LTD. potvrzuje, da je tip radijske opreme B3N2K2R skladen z Direktivo 2014/53/EU.

Celotno besedilo izjave EU o skladnosti je na voljo na naslednjem spletnem naslovu:

<http://www.tokai-rika.co.jp/pc>

Frekvenčni pas: 433.050 - 434.790 MHz
Največja moč radijske frekvence: 10mW(ERP)

Aš, TOKAI RIKA CO., LTD., patvirtinu, kad radijo įrenginių tipas B3N2K2R atitinka Direktyvą 2014/53/ES.

Visas ES atitikties deklaracijos tekstas prieinamas šiuo interneto adresu:

<http://www.tokai-rika.co.jp/pc>

Dažnių juosta: 433.050 - 434.790 MHz
Didžiausia radijo dažnių galia: 10mW(ERP)

Ar šo TOKAI RIKA CO., LTD. deklarė, ka radioiekārta B3N2K2R atbilst Direktīvai 2014/53/ES.

Pilns ES atbilstības deklarācijas teksts ir pieejams šādā interneta vietnē:

<http://www.tokai-rika.co.jp/pc>

Frekvenču josla: 433.050 - 434.790 MHz
Maksimālā radiofrekvenču jauda: 10mW(ERP)

TOKAI RIKA CO., LTD. niniejszym oświadcza, że typ urządzenia radiowego B3N2K2R jest zgodny z dyrektywą 2014/53/UE.

Pełny tekst deklaracji zgodności UE jest dostępny pod następującym adresem internetowym:

<http://www.tokai-rika.co.jp/pc>

Zakres częstotliwości: 433.050 - 434.790 MHz

Maksymalna moc częstotliwości radiowej: 10mW(ERP)

TOKAI RIKA CO., LTD. lýsir því hér með yfir að fjarskiptatækið af gerð B3N2K2R er í samræmi við tilskipun 2014/53/EU.

Öll ESB-samræmisýfirlýsingin er tiltæk á eftirfarandi vefslóð:

<http://www.tokai-rika.co.jp/pc>

Tíðnisvið: 433.050 - 434.790 MHz

Hámarks útvarpsbylgjutíðni: 10mW(ERP)

TOKAI RIKA CO., LTD. erklærer herved at radioutstyrten B3N2K2R er i samsvar med direktivet 2014/53/EU.

Hele teksten av EU-samsvarserklæringen kan leses på det følgende nettstedet:

<http://www.tokai-rika.co.jp/pc>

Frekvensbånd: 433.050 - 434.790 MHz

Maksimal radiofrekvensseffekt: 10mW(ERP)

С настоящото TOKAI RIKA CO., LTD. декларира, че този тип радиосъоръжение B3N2K2R е в съответствие с Директива 2014/53/ЕС.

Цялостният текст на ЕС декларацията за съответствие може да се намери на следния интернет адрес:

<http://www.tokai-rika.co.jp/pc>

Радиочестотна лента: 433.050 - 434.790 MHz

Максимална радиочестотна мощност: 10mW(ERP)

Prin prezenta, TOKAI RIKA CO., LTD. declară că tipul de echipamente radio B3N2K2R este în conformitate cu Directiva 2014/53/UE.

Textul integral al declarației UE de conformitate este disponibil la următoarea adresă internet:

<http://www.tokai-rika.co.jp/pc>

Banda de frecvență: 433.050 - 434.790 MHz

Puterea maximă de radiofrecvență: 10mW(ERP)

Ovime TOKAI RIKA CO., LTD. potvrđuje da je radio-oprema tipa B3N2K2R u skladu sa Direktivom 2014/53/EU.

Potpuni tekst EU deklaracije o usaglašenosti dostupan je na slijedećoj internet adresi:

<http://www.tokai-rika.co.jp/pc>

Frekvencijski opseg: 433.050 - 434.790 MHz

Maksimalna radio-frekvencijska snaga: 10mW(ERP)

Me anë të këtij dokumenti, TOKAI RIKA CO., LTD. deklararon se tipi i radiopajisjes B3N2K2R është në përputhje me Direktivën 2014/53/EU.

Teksti i plotë i deklaratës së konformitetit të Bashkimit Evropian është i disponueshëm në adresën e mëposhtme të internetit:

<http://www.tokai-rika.co.jp/pc>

Brezi i frekuencës: 433.050 - 434.790 MHz

Fuqia maksimale e radiofrekuencës: 10mW(ERP)

TOKAI RIKA CO., LTD. ovime izjavljuje da je radijska oprema tipa B3N2K2R u skladu s Direktivom 2014/53/EU.

Cjeloviti tekst EU izjave o sukladnosti dostupan je na sljedećoj internetskoj adresi:

<http://www.tokai-rika.co.jp/pc>

Frekvencijski pojas: 433.050 - 434.790 MHz
Maksimalna RF snaga: 10mW(ERP)

Ovim TOKAI RIKA CO., LTD. potvrđuje da je radio-oprema tipa B3N2K2R u skladu sa Direktivom 2014/53/EU.

Potpuni tekst EU deklaracije o usaglašenosti dostupan je na sledećoj internet adresi:

<http://www.tokai-rika.co.jp/pc>

Frekventni opseg: 433.050 - 434.790 MHz
Maksimalna radio-frekventna snaga: 10mW(ERP)

TOKAI RIKA CO., LTD., işbu belgeyle telsiz cihazı türünün B3N2K2R 2014/53/EU nolu Direktif ile uyumlu olduğunu beyan etmektedir.

AB uygunluk beyanının tam metnine aşağıdaki internet adresinden ulaşabilirsiniz:

<http://www.tokai-rika.co.jp/pc>

Frekans bandı: 433.050 - 434.790 MHz
Maksimum radyo frekans gücü: 10mW(ERP)



Address: 3-260 Toyota, Oguchi-cho, Niwa-gun, Aichi 480-0195, Japan

- ⚠: This mark is a safety/warning mark.
- Do not ingest battery.
- Chemical Burn Hazard**
- This product contains a coin / button cell battery.
 - If the coin / button cell battery is swallowed, it can cause severe internal burns in just 2 hours and can lead to death.
 - Keep new and used batteries away from children.
 - If the battery compartment does not close securely, stop using the product and keep it away from children.
 - If you think batteries might have been swallowed or placed inside any part of the body, seek immediate medical attention.
- CAUTION**
- Risk of explosion if the battery is replaced by an incorrect type.
 - Replace battery with the same type.
- CAUTION**
- Risk of explosion or the leakage of flammable liquid or gas.
-
- Do not use in /store in /bring into environment of extremely high temperature or extremely low pressure due to the very high altitude.
 - Do not attempt to burn, crush, or cut used battery.

⚠ : Tämä on turva-/varoitusmerkki.

- Paristoa ei saa laittaa suuhun.

Kemiallisen palovamman vaara

- Laitteessa on kolikko-/nappiparisto.
- Elimistöön joutunut kolikko-/nappiparisto voi aiheuttaa vakavia sisäisiä palovammoja vain 2 tunnissa, jolloin seurauksena voi olla hengen menetys.
- Uudet ja käytetyt paristot on pidettävä poissa lasten ulottuvilta.
- Jos paristolokero ei sulkeudu kunnolla, laitteen käyttö on lopetettava, ja laite on pidettävä poissa lasten ulottuvilta.
- Jos on syytä epäillä, että paristo on nielaistu tai muuten päässyt elimistöön, ota välittömästi yhteyttä lääkäriin.

TÄRKEÄ HUOMAUTUS

- Käytetyn pariston vaihtaminen tyypiltään väärään voi aiheuttaa räjähdysvaaran.
- Vaihda paristo tyypiltään samanlaiseen.

TÄRKEÄ HUOMAUTUS

- Räjähdysvaara tai syttyvän nesteen tai kaasun vuotovaara.
- Ei saa käyttää/säilyttää/tuoda lämpötilaltaan tai merenpinnasta mitattuna erittäin korkeaan ympäristöön, jossa ilmanpaine on erittäin alhainen.
- Käytettyä paristoa ei saa polttaa, murskata tai halkaista.

⚠ : Dit teken is een veiligheids-/waarschuwingsteken.

- Slik de batterij niet in.

Risico op chemische brandwonden

- Dit product bevat een munt-/knoopcelbatterij.
- Als de munt-/knoopcelbatterij wordt ingeslikt, kan het al binnen 2 uur ernstige interne brandwonden veroorzaken en de dood tot gevolg hebben.
- Houd nieuwe en gebruikte batterijen buiten bereik van kinderen.
- Als het batterijcompartiment niet goed sluit, stop dan met het gebruik van het product en houd het buiten bereik van kinderen.
- Als u denkt dat batterijen zijn ingeslikt of in enig deel van het lichaam zijn gestopt, roep dan onmiddellijk medische hulp in.

VOORZICHTIG

- Er bestaat een risico op ontploffing als de batterij wordt vervangen door een verkeerd type.
- Vervang de batterij door een van hetzelfde type.

VOORZICHTIG

- Er bestaat een risico op ontploffing of lekkage van brandbare vloeistof of gas.
- Niet gebruiken in/bewaren in/meenemen naar een omgeving met extreem hoge temperatuur of met extreem lage druk als gevolg van zeer grote hoogte.
- Een gebruikte batterij niet verbranden, platdrukken, of doorsnijden.

 : Ce pictogramme est une marque de sécurité/avertissement.

• Ne pas ingérer la pile.

Risques de brûlure chimique

- Ce produit contient une pile bouton.
- Si la pile bouton est avalée, elle peut causer de graves brûlures internes en seulement 2 heures et peut entraîner la mort.
- Conservez les piles neuves et usagées hors de portée des enfants.
- Si le compartiment de la pile ne ferme pas correctement, cessez d'utiliser le produit et conservez-le hors de portée des enfants.
- Si vous pensez que des piles ont pu être avalées ou placées à l'intérieur d'une partie du corps, consultez immédiatement un médecin.

AVERTISSEMENT

- Risque d'explosion si la pile est remplacée par un type incorrect.
- Remplacez la pile par une pile du même type.

AVERTISSEMENT

- Risque d'explosion ou de fuite de liquide ou de gaz inflammable.

• Ne jamais utiliser, stocker, placer dans un environnement à la température extrêmement élevée ou à la pression extrêmement basse en raison d'une très haute altitude.

• Ne jamais essayer de brûler, écraser ou couper des piles usagées.

: Det här märket är ett säkerhets-/varningsmärke.

• Förtär inte batteriet.

Risk för kemisk brännskada

- Den här produkten innehåller ett mynt-/knappbatteri.
- Om mynt-/knappbatteriet sväljs kan det orsaka allvarliga interna brännskador på bara två timmar, vilket kan leda till dödsfall.
- Håll nya och använda batterier borta från barn.
- Om batterifacket inte stängs ordentligt, sluta använda produkten och håll den undan från barn.
- Om du misstänker att batterier har svalts eller placerats inuti någon del av kroppen, sök omedelbart läkarvård.

VARNING

- Risk för explosion om batteriet byts ut mot ett av fel typ.
- Byt ut batteriet mot ett av samma typ.

VARNING

- Risk för explosion eller läckage av brandfarliga vätskor och gaser.

• Använd inte, förvara inte och ta inte in i miljö med extremt hög temperatur eller extremt lågt tryck p.g.a. hög höjd.

• Försök inte bränna, krossa eller skära använt batteri.

⚠ : Dette mærke er et sikkerheds-/advarselmærke.

- Batteriet må ikke indtages.

Fare for kemisk forbrænding

- Dette produkt indeholder et mønt-/knapcellebatteri.
- Hvis mønt-/knapcellebatteriet sluges, kan det medføre alvorlige indre forbrændinger i løbet af kun 2 timer og kan føre til dødsfald.
- Opbevar nye og brugte batterier utilgængeligt for børn.
- Hvis batterirummet ikke kan lukkes ordentligt, skal du indstille brugen af produktet og opbevare det utilgængeligt for børn.
- Hvis du har mistanke om, at der måske er blevet slugt batterier, eller batterier på anden måde er kommet ind i kroppen, skal du øjeblikkeligt søge lægehjælp.

FORSIGTIG

- Risiko for eksplosion, hvis batteriet udskiftes med en forkert type.
- Udskift batteriet med et batteri af samme type.

FORSIGTIG

- Risiko for eksplosion eller lækage af brændbar væske eller gas.
- Må ikke anvendes på/opbevares på/tages med til meget varme steder eller steder med meget lavt tryk som følge af ekstreme højder.
- Forsøg ikke at brænde, knuse eller adskille brugte batterier.

⚠: Dieses Symbol ist ein Sicherheits-/Warnsymbol.

- Verschlucken Sie die Batterie nicht.

Verätzungsgefahr

- Dieses Produkt enthält eine Knopfzellenbatterie.
- Falls die Knopfzellenbatterie verschluckt wird, kann dies innerhalb von nur 2 Stunden schwere innere Verätzungen verursachen und zum Tode führen.
- Halten Sie neue und gebrauchte Batterien von Kindern fern.
- Falls sich das Batteriefach nicht sicher schließen lässt, stellen Sie die Verwendung des Produkts ein und halten Sie es von Kindern fern.
- Falls Sie glauben, dass Batterien eventuell verschluckt oder in einen Teil des Körpers eingeführt worden sind, begeben Sie sich sofort in ärztliche Behandlung.

ACHTUNG

- Es besteht Explosionsgefahr, falls die Batterie durch eine Batterie der falschen Art ersetzt wird.
- Ersetzen Sie Batterien nur durch die gleiche Art.

ACHTUNG

- Es besteht Explosionsgefahr oder die Gefahr eines Austritts von brennbarer Flüssigkeit oder entzündlichem Gas.
- Das Produkt darf nicht in Umgebungen mit hohen Temperaturen oder extrem niedrigem Luftdruck aufgrund von extremen Höhenlagen verwendet / aufbewahrt / gebracht werden.
- Versuchen Sie nicht, gebrauchte Batterien zu verbrennen, zu zerstoßen oder zu schneiden.

⚠: Το σήμα αυτό είναι ένα σήμα ασφαλείας/προειδοποίησης.

- Μην καταπίνετε την μπαταρία.

Κίνδυνος χημικού εγκαύματος

- Αυτό το προϊόν περιέχει μια μπαταρία σχήματος νομίσματος / κουμπιού.
- Αν η μπαταρία σχήματος νομίσματος / κουμπιού καταποθεί, μπορεί να προκαλέσει σοβαρά εσωτερικά εγκαύματα σε μόλις 2 ώρες και μπορεί να επέλθει θάνατος.
- Διατηρείτε τις καινούργιες και τις χρησιμοποιημένες μπαταρίες μακριά από παιδιά.
- Εάν το διαμέρισμα της μπαταρίας δεν κλείνει καλά, σταματήστε τη χρήση του προϊόντος και κρατήστε το μακριά από παιδιά.
- Αν νομίζετε ότι οι μπαταρίες ενδέχεται να έχουν καταποθεί ή τοποθετηθεί μέσα σε οποιοδήποτε μέρος του σώματος, ζητήστε αμέσως ιατρική φροντίδα.

ΠΡΟΣΟΧΗ

- Υπάρχει κίνδυνος έκρηξης εάν η μπαταρία αντικατασταθεί με μπαταρία εσφαλμένου τύπου.
- Αντικαταστήστε την μπαταρία με μπαταρία του ίδιου τύπου.

ΠΡΟΣΟΧΗ

- Υπάρχει κίνδυνος έκρηξης ή διαρροής εύφλεκτων υγρών ή αερίων.
- Μη χρησιμοποιείτε / αποθηκεύετε / μεταφέρετε το προϊόν σε περιβάλλον με εξαιρετικά υψηλή θερμοκρασία ή εξαιρετικά χαμηλή πίεση λόγω πολύ μεγάλου υψομέτρου.
- Μην επιχειρήσετε να κάψετε, να συνθλίψετε ή να κόψετε μια χρησιμοποιημένη μπαταρία.

⚠ : Questo è un simbolo di sicurezza/avvertenza.

- Non ingerire la batteria.

Pericolo di ustioni chimiche

- Questo prodotto contiene una batteria a bottone/moneta.
- Se la batteria a bottone/moneta viene ingerita, può causare gravi ustioni interne in sole 2 ore e provocare la morte.
- Tenere le batterie nuove e usate lontano dalla portata dei bambini.
- Se il vano batteria non si chiude in modo saldo, interrompere l'utilizzo del prodotto e tenerlo lontano dalla portata dei bambini.
- Se si ritiene che le batterie siano state ingerite o inserite in qualsiasi parte del corpo, consultare immediatamente un medico.

ATTENZIONE

- Rischio di esplosione in caso di sostituzione della batteria con una di tipo errato.
- Sostituire la batteria con una dello stesso tipo.

ATTENZIONE

- Rischio di esplosione o di perdita di liquidi o gas infiammabili.
- Non utilizzare / immagazzinare / portare in ambienti con temperatura estremamente alta o pressione estremamente alta a causa dell'elevata altitudine.
- Non provare a bruciare, schiacciare o tagliare la batteria usata.

⚠: Este símbolo es un símbolo de seguridad/precaución.

- No ingerir la batería.

Peligro de quemadura química

- Este producto contiene una batería de pila de botón.
- Si se ingiere la batería de pila de botón, esta puede causar graves quemaduras internas en solo 2 horas y puede provocar la muerte.
- Mantenga las baterías nuevas y usadas alejadas de los niños.
- Si el compartimento de la batería no se cierra correctamente, deje de usar el producto y manténgalo alejado de los niños.
- Si cree que las baterías hayan podido ser ingeridas o introducidas en alguna parte del cuerpo, busque inmediatamente atención médica.

ATENCIÓN

- Riesgo de explosión si la batería es reemplazada por una del tipo incorrecto.
- Reemplace la batería por una del mismo tipo.

ATENCIÓN

- Riesgo de explosión o escape de líquido o gas inflamable.
- No usar / almacenar / introducir en un ambiente de temperatura extremadamente alta o de presión extremadamente baja a causa de la alta altitud.
- No intente quemar, aplastar, o cortar la batería usada.

⚠: Esta marca é uma marca de segurança/aviso.

- Não ingerir a pilha.

Perigo de Queimadura Química

- Este produto contém uma pilha de tipo moeda/botão.
- Se a pilha de tipo moeda/botão for engolida, poderá causar queimaduras internas graves em apenas 2 horas e levar à morte.
- Manter as pilhas novas e usadas longe de crianças.
- Se o compartimento da pilha não se fechar completamente, cessar a utilização do produto e manter fora do alcance das crianças.
- Caso seja possível que as pilhas tenham sido engolidas ou colocadas dentro de qualquer parte do corpo, procurar cuidados médicos imediatamente.

CUIDADO

- Risco de explosão se a pilha for substituída por uma de tipo incorreto.
- Substituir a pilha por uma do mesmo tipo.

CUIDADO

- Risco de explosão ou fuga de líquidos ou gases inflamáveis.
- Não utilizar/armazenar/colocar em ambiente de temperatura extremamente alta, ou pressão extremamente baixa devido a altitude muito alta.
- Não tentar queimar, esmagar ou cortar a pilha usada.

⚠: Din il-marka hija marka ta' sigurtá/twissija.

- Tiblax il-batterija.

Periklu ta' Hruq Kimiku

- Dan il-prodott fih batterija munita / button cell.
- Jekk tinbela' l-batterija munita / button cell, tista' tikkawza hruq intern sever f'temp ta' sagħtejn biss u tista' twassal għall-mewt.
- Żomm il-batteriji godda u użati 'l bogħod mit-tfal.
- Jekk il-kompartiment tal-batterija ma jagħlaqx sew, waqqaf l-użu tal-prodott u zommu 'l bogħod mit-tfal.
- Jekk taħseb li l-batteriji setgħu nbelgħu jew tpoġġew gewwa xi parti tal-gisem, fittex attenzjoni medika immedjata.

ATTENZJONI

- Riskju ta' splużjoni jekk il-batterija tiġi ssostitwita b'tip inkorrett.
- Ibdel il-batterija bl-istess tip.

ATTENZJONI

- Riskju ta' splużjoni jew tnixxija ta' likwidu jew gass f'ammabbli.

- Tużahx / taħznux / iġġibux f'ambjent ta' temperatura estremament għolja jew pressjoni estremament baxxa minħabba l-altitudni għolja ħafna.
- Tippruvax taħraq, tfarrak jew tqatta' l-batteriji użati.

⚠: See märk on ohutus-/hoiatusmärk.

- Äрге патарейд alla neelake.

Keemilise põletuse oht

- See toode sisaldab mündi/nõõbi tüüpi elemendiga patareid.
- Mündi/nõõbi tüüpi elemendiga patareid allaneelamine võib põhjustada raskeid sisemisi põletusi juba 2 tunni jooksul ning võib lõppeda surmaga.
- Hoidke uued ja kasutatud patareid lastele kättesaamatus kohas.
- Kui patareipesa ei sulgu kindlalt, lõpetage toote kasutamine ja hoidke seda lastele kättesaamatus kohas.
- Kui te arvate, et patareid võivad olla alla neelatud või mistahes kehaossa sattunud, pöörduge viivitamatult arsti poole.

ETTEVAATUST

- Plahvatusoht vahetamisel vale tüüpi patareiga.
- Vahetage sama tüüpi patareiga.

ETTEVAATUST

- Plahvatuse või tuleohtliku vedeliku või gaasi lekke oht.

- Äрге kasutage, hoidke ega tooge keskkonda eriti kõrge temperatuuriga või eriti madala rõhuga väga suure kõrguse tõttu merepinnast.
- Äрге üritage põletada, purustada ega lõigata kasutatud patareid.

⚠ : Ez a jelzés biztonsági/figyelmeztető jelzés.

- Ne nyelje le az elemet.

Vegyí anyag okozta égésisérülés-veszély

- Ez a termék gomelemet tartalmaz.
- Amennyiben a gomelemet lenyeli, az mindössze 2 órán belül komoly belső égési sérüléseket okozhat és halálhoz vezethet.
- Az új és használt elemeket tartsa távol a gyermekektől.
- Amennyiben az elemtartó rekesz nem zárható biztonságosan, függessze fel a termék használatát és tartsa gyermekektől távol.
- Amennyiben úgy véli, hogy az elemet lenyelték vagy bármely testrészbe helyezték, haladéktalanul forduljon orvoshoz.

VIGYÁZAT

- Nem megfelelő típusú csereelem használata robbanásveszélyes.
- Az elemcseréhez azonos típusú elemet használjon.

VIGYÁZAT

- Robbanásveszély vagy gyúlékony folyadékok vagy gázok szivárgása.

• Ne használja/ne tárolja/ne helyezze szélsőségesen magas hőmérsékletű környezetbe, és ne tegye ki a nagy magasságokban kialakuló rendkívül alacsony nyomásnak.

• A használt elemet ne kísérelje meg elégetni, összezúzni vagy szétvágni.

⚠ : Toto je bezpečnostná/výstražná značka.

- Dbajte na to, aby nedošlo k prehltntiu batérie.

Nebezpečenstvo poleptania chemikáliou

- Tento výrobok obsahuje mincovú/gombíkovú batériu.
- Ak dôjde k prehltntiu mincovej/gombíkovej batérie, už v priebehu 2 hodín môže spôsobiť vážne vnútorné poleptanie a viesť k usmrteniu.
- Nové a použité batérie uchovávajte mimo dosahu detí.
- Ak sa priestor pre batériu nezatvorí bezpečne, prestaňte používať výrobok a uchovávajte ho mimo dosahu detí.
- Ak si myslíte, že mohlo dôjsť k prehltntiu batérií alebo ich umiestneniu do ktorejkoľvek časti tela, okamžite vyhľadajte lekársku pomoc.

UPOZORNENIE

- Hrozí nebezpečenstvo výbuchu, ak sa batéria vymení za nesprávny typ.
- Vymeňte batériu za rovnaký typ.

UPOZORNENIE

- Nebezpečenstvo výbuchu alebo úniku horľavej kvapaliny alebo horľavého plynu.

• Nepoužívajte/neskladujte v prostredí/neprinášajte do prostredia s mimoriadne vysokou teplotou, alebo mimoriadne nízkym tlakom v dôsledku veľmi vysokej nadmorskej výšky.

• Nepokúšajte sa spáliť, rozdrviť ani rozrezať použitú batériu.

<p>⚠ : Tento symbol je bezpečnostním/výstražným symbolem.</p> <ul style="list-style-type: none"> • Baterii nepolykejte. <p>Nebezpečí chemických popálenin</p> <ul style="list-style-type: none"> • Tento výrobek obsahuje mincovou/knoflíkovou baterii. • Pokud dojde ke spolknutí mincové/knoflíkové baterie, může za pouhé 2 hodiny způsobit závažné vnitřní popáleniny a v jejich důsledku případně i smrt. • Použité a nové baterie udržujte mimo dosah dětí. • Pokud nelze prostor pro baterii pevně uzavřít, přestaňte výrobek používat a udržujte jej mimo dosah dětí. • Pokud si myslíte, že mohlo dojít ke spolknutí baterie nebo jejímu vsunutí dovnitř kterékoliv části těla, okamžitě vyhledejte lékařskou pomoc. <p>UPOZORNĚNÍ</p> <ul style="list-style-type: none"> • Nebezpečí výbuchu v případě výměny baterie za nesprávný druh baterie. • Proto baterii vždy vyměňte za jinou stejného typu. <p>UPOZORNĚNÍ</p> <ul style="list-style-type: none"> • Nebezpečí výbuchu nebo úniku hořlavé kapaliny či plynu. <ul style="list-style-type: none"> • Nepoužívejte/neskladujte/nepřinášejte je do prostředí s nesmírně vysokou teplotou nebo nesmírně nízkým tlakem zapříčiněným vysokou nadmořskou výškou. • Nesnažte se baterii spálit, rozdrtit či rozříznout.
<p>⚠ : Ta oznaka je varnostna/opozorilna oznaka.</p> <ul style="list-style-type: none"> • Ne zaužijte baterije. <p>Nevarnost kemijske opekline</p> <ul style="list-style-type: none"> • Ta izdelek vsebuje gumbasto baterijo. • Če se gumbasto baterijo zaužije, lahko to povzroči hude notranje opekline v le 2 urah in lahko vodi v smrt. • Nove in rabljene baterije hranite izven dosega otrok. • Če se predalček za baterijo ne zapira pravilno, prenehajte z uporabo izdelka in ga hranite izven dosega otrok. • Če sumite, da je morda nekdo zaužil baterijo ali jo dal v kateri koli del telesa, takoj poiščite zdravniško pomoč. <p>POZOR</p> <ul style="list-style-type: none"> • Nevarnost eksplozije, če baterijo zamenjate z baterijo napačne vrste. • Zamenjajte baterijo z istim tipom. <p>POZOR</p> <ul style="list-style-type: none"> • Tveganje za eksplozijo ali puščanje vnetljivih tekočin ali plinov. <ul style="list-style-type: none"> • Ne uporabljajte/shranjujte/prinašajte v okolje izredno visoke temperature ali izredno nizkega tlaka zaradi zelo visoke nadmorske višine. • Ne poskušajte zažigati, uničiti, ali rezati rabljene baterije.

⚠: Šis ženklas yra saugos/įspėjamasis ženklas.

- Neprarykite baterijos.

Cheminio nudegimo pavojus

- Šiame gaminyje yra monetos/sagos formos baterija.
- Prarijęs monetos/sagos formos bateriją, asmuo per 2 valandas gali patirti sunkius vidinius nudegimus ir netgi mirti.
- Naujas ir panaudotas baterijas laikykite vaikams nepasiekiamoje vietoje.
- Jei baterijų skyrelio nepavyksta tvirtai uždaryti, nebenaudokite gaminio ir laikykite jį vaikams nepasiekiamoje vietoje.
- Jei manote, kad baterijos buvo prarytos arba pateko į kūną, nedelsdami kreipkitės į gydytoją.

PERSPĖJIMAS

- Bateriją pakeitus netinkamo tipo baterija, kyla sprogo pavojus.
- Pakeiskite seną bateriją tik to paties tipo nauja baterija.

PERSPĖJIMAS

- Sprogimo arba degių skysčių ar dujų nuotėkio pavojus.
- Negalima naudoti/laikyti/turėti labai aukštos temperatūros arba labai dideliame aukštyje esančioje itin žemo slėgio aplinkoje.
- Naudotos baterijos nebandykite deginti, ardyti ar perpjauti.

⚠ : Ši žīme ir drošības/brīdinājuma zīme.

- Nenorijiet bateriju.

Ķīmisku apdegumu briesmas

- Šis izstrādājums satur tabletes tipa bateriju.
- Ja ir norīta tabletes tipa baterija, tā 2 stundu laikā var radīt smagus apdegumus un izraisīt nāvi.
- Jaunas un lietotas baterijas uzglabājiet bērniem nepieejamā vietā.
- Ja bateriju nodalījumu nevar droši aizvērt, pārtrauciet lietot izstrādājumu un novietojiet to bērniem nepieejamā vietā.
- Ja jūsuprāt baterijas ir norītas vai ievietotas kādā ķermeņa daļā, nekavējoties vērsieties pēc medicīniskās palīdzības.

UZMANĪBU!

- Eksplozijas risks, ja baterija tiek nomainīta ar nepareiza tipa bateriju.
- Bateriju nomainiet pret tāda paša tipa bateriju.

UZMANĪBU!

- Eksplozijas vai uzliesmojoša šķidrums vai gāzes noplūdes risks.
- Nelietojiet, neuzglabājiet un neievietojiet vidē ar ļoti augstu temperatūru, kā arī vidē, kur ļoti lielā augstuma virs jūras līmeņa dēļ ir ļoti zems spiediens.
- Nemēģiniet sadedzināt, sagraut vai sagriezt nolietoto bateriju.

 : ten symbol oznacza niebezpieczeństwo/ostrzeżenie.

- Nie połykać baterii.

Ryzyko oparzenia chemicznego

- Ten produkt zawiera baterię guzikową.
- Połknięta bateria guzikowa może spowodować poważne oparzenia wewnętrzne w czasie jedynie 2 godzin i prowadzić do śmierci.
- Przechowywać nowe i zużyte baterie z dala od dzieci.
- Jeśli solidne zamknięcie komory baterii jest niemożliwe, zaprzestać użytkowania produktu i przechowywać go w miejscu niedostępnym dla dzieci.
- W przypadku podejrzenia, że mogło dojść do połknięcia baterii lub ich umieszczenia w dowolnym otworze ciała, niezwłocznie uzyskać pomoc lekarską.

PRZESTROGA

- Istnieje ryzyko wybuchu, jeśli bateria zostanie zastąpiona baterią niewłaściwego typu.
- Wymieniać baterię na baterię tego samego typu.

PRZESTROGA

- Ryzyko wybuchu lub wycieku łatwopalnego płynu lub gazu.

• Nie używać i nie przechowywać w otoczeniu o skrajnie wysokiej temperaturze lub skrajnie niskim ciśnieniu wynikającym z bardzo dużej wysokości ani nie wносить do takiego otoczenia.

• Nie podejmować prób spalania, zgniecenia lub przecięcia zużytej baterii.

 : Този знак е знак за безопасност/предупреждение.

- Не поглъщайте батерията.

Опасност от химическо изгаряне

- Този продукт съдържа плоска/бутонна батерия.
- Ако плоската/бутонна батерия бъде погълната, тя може да причини тежки вътрешни изгаряния само за 2 часа и може да доведе до смърт.
- Пазете новите и използваните батерии далеч от деца.
- Ако отделението за батериите не се затваря добре, спрете да използвате продукта и го дръжте далеч от деца.
- Ако смятате, че батериите може да са били погълнати или поставени в някоя част на тялото, незабавно потърсете медицинска помощ.

ВНИМАНИЕ

- Опасност от експлозия, ако батерията бъде сменена с неправилен тип.
- Сменете батерията със същия вид.

ВНИМАНИЕ

- Опасност от експлозия или изтичане на запалими течности или газове.

• Не използвайте/съхранявайте/носете в среда с изключително висока температура или изключително ниско налягане, причинено от голямата височина.

• Не се опитвайте да изгаряте, смачквате или режете използваната батерия.

⚠ : Acest marcaj este un marcaj de securitate/avertizare.

•Nu ingerați bateria.

Pericol de arsuri chimice

•Acest produs conține o baterie tip pastilă.

•Dacă bateria tip pastilă este înghițită, aceasta poate cauza arsuri interne grave în numai 2 ore și poate duce la deces.

•Nu lăsați bateriile noi și bateriile uzate la îndemâna copiilor.

•În cazul în care compartimentul bateriei nu se închide bine, încetați utilizarea produsului și nu îl lăsați la îndemâna copiilor.

•Dacă bănuiți că este posibil ca bateriile să fi fost înghițite sau introduse în orice parte a corpului, consultați imediat medicul.

ATENȚIE

•Risc de explozie dacă bateria este înlocuită cu un tip incorect.

•Înlocuiți bateria cu una de același tip.

ATENȚIE

•Risc de explozie sau de scurgeri de lichide sau gaze inflamabile.

•Nu utilizați/depozitați într-un mediu cu temperatură extrem de înaltă sau cu presiune extrem de joasă din cauza altitudinii foarte mari.

•Nu încercați să ardeți, să spargeți sau să tăiați bateriile uzate.

⚠ : Ova oznaka je oznaka sigurnosti/upozorenja.

•Nemojte gutati bateriju.

Opasnost od kemijskih opekline

•Ovaj proizvod sadrži novčić/gumb bateriju.

•Ako se novčić/gumb baterija proguta, može uzrokovati ozbiljne unutarnje opekline u samo 2 sata i može dovesti do smrti.

•Držite nove i rabljene baterije izvan dohvata djece.

•Ako se pretinac za baterije ne zatvara sigurno, prestanite koristiti proizvod i držite ga dalje od djece.

•Ako smatrate da su baterije možda progutane ili smještene unutar bilo kojeg dijela tijela, zatražite hitnu medicinsku pomoć.

OPREZ

•Ako je baterija zamijenjena pogrešnim tipom, postoji rizik od eksplozije.

•Zamijenite bateriju s baterijama iste vrste.

OPREZ

•Rizik od eksplozije ili istjecanja zapaljive tekućine ili plina.

•Nemojte koristiti u /pohranjivati u /unijeti u prostoru izuzetno visoke temperature ili izuzetno niskog tlaka zbog visoke nadmorske visine.

•Ne pokušavajte spaliti, lomiti ili rezati istrošenu bateriju.

⚠ : Þetta tákn er öryggis-/aðvöruntákn.

- Gleypið ekki rafhlöðuna.

Hætta á efnabruna

- Þessi vara inniheldur flata rafhlöðu.
- Ef rafhlaðan er gleypt getur hún valdið alvarlegum innvortis bruna á innan við 2 klukkustundum sem getur leitt til dauða.
- Geymið nýjar og notaðar rafhlöður þar sem börn ná ekki til.
- Ef rafhlöðuhólfíð lokast ekki örugglega skal hætta notkun vörunnar og geyma hana þar sem börn ná ekki til.
- Ef þú telur að rafhlöður hafi verið gleyptar eða settar inn í eitthvert líkamsop, skaltu hafa samband við lækni tafarlaust.

VARÚÐ

- Hætta á sprengingu ef rafhlöðunni er skipt út fyrir ranga tegund.
- Skiptið rafhlöðunni ávallt út fyrir sömu tegund.

VARÚÐ

- Hætta á sprengingu eða leka á eldfimum vökva eða lofttegundum.

• Má ekki nota/geyma/setja í umhverfi þar sem er afar hár hiti, eða afar lágur þrýstingur vegna mikillar hæðar.

- Ekki reyna að brenna, kremja eða skera notaða rafhlöðu.

⚠ : Dette merket er et sikkerhets-/advarselsmerke.

- Ikke svelg batteriet.

Kjemisk brannfare

- Dette produktet inneholder et mynt-/knappecellebatteri.
- Dersom mynt-/knappecellebatteriet svelges, kan det frembringe alvorlige indre forbrenninger i løpet av kun to timer, og kan være dødelig.
- Hold nye og brukte batterier borte fra barn.
- Lukkes ikke batterirommet sikkert må du stanse å bruke produktet og holde det utenfor barns rekkevidde.
- Oppsøk medisinsk hjelp umiddelbart hvis du tror at batterier kan være svelget eller plassert inne i kroppen.

FORSIKTIG

- Eksplosjonsfare hvis batteriet erstattes med feil type.
- Bytt batteri med samme type.

FORSIKTIG

- Fare for eksplosjon eller lekkasje av brannfarlig væske eller gass.

• Ikke bruk i/oppbevar i/ta med inn i miljø med ekstremt høy temperatur eller ekstremt lavt trykk på grunn av den svært store høyden.

- Ikke forsøk å brenne, knuse eller skjære opp et brukt batteri.

⚠ : Ova oznaka je sigurnosna/upozoravajuća oznaka.

•Nemojte gutati bateriju.

Opasnost od hemijskih opekotina

•Ovaj proizvod sadrži bateriju veličine kovanice/dugmeta.

•Ako se baterija veličine kovanice/dugmeta proguta, može izazvati ozbiljne unutrašnje opekotine za samo 2 sata i može dovesti do smrti.

•Čuvajte nove i korišćene baterije dalje od djece.

•Ako se prostor za baterije ne zatvori dobro, prestanite sa korišćenjem proizvoda i držite ga dalje od djece.

•Ako mislite da su baterije možda progutane ili stavljene u unutrašnjost bilo kog dijela tijela, potražite hitnu medicinsku pomoć.

OPREZ

•Opasnost od eksplozije ako se baterija zamijeni s baterijom pogrešnog tipa.

•Zamijenite bateriju sa baterijom istog tipa.

OPREZ

•Opasnost od eksplozije ili curenja zapaljive tečnosti ili gasa.

•Nemojte koristiti /skladištiti /unositi u okruženje izuzetno visoke temperature ili izuzetno niskog pritiska usljed veoma velike visine.

•Ne pokušavajte da spalite, lomite ili isječete iskorišćenu bateriju.

⚠ : Kjo është shenjë sigurie/paralajmërimi.

•Mos e gëlltisni baterinë.

Rrezik djegieje kimike

•Ky produkt përmban një bateri të hollë në formë monedhe/kopse.

•Nëse bateria e hollë në formë monedhe/kopse gëlltitet, ajo mund të shkaktojë djegie të rënda të brendshme brenda vetëm 2 orëve dhe mund të sjellë vdekjen.

•Mbajini bateritë e reja dhe të përdorura larg nga fëmijët.

•Nëse foleja e baterisë nuk mbyllet mirë, ndaloni përdorimin e produktit dhe mbajeni larg nga fëmijët.

•Nëse mendoni se bateritë mund të jenë gëlltitur ose futur brenda ndonjë pjese trupi, kërkoni menjëherë vëmendjen e mjekut.

KUJDES

•Rrezik shpërthimi nëse bateria zëvendësohet me një lloj të pasaktë.

•Zëvendësojeni baterinë me të njëjtin lloj.

KUJDES

•Rrezik shpërthimi nga rrjedhja e lëngut apo gazit të ndezshëm.

•Mos e përdorni / ruani / sillni në mjedise me temperaturë jashtëzakonisht të lartë ose presion jashtëzakonisht të ulët në lartësi shumë të mëdha.

•Mos u përipiqi të digjni, shtypni ose prisni baterinë e përdorur.

⚠ : Ova oznaka je oznaka za bezbednost/upozorenje.

•Nemojte gutati bateriju.

Opasnost od hemijskih opekotina

- Ovaj proizvod sadrži bateriju u obliku novčića/dugmeta.
- Ako se baterija u obliku novčića/gumba proguta, može da izazove ozbiljne interne opekotine za samo 2 sata i može da dovede do smrti.
- Nove i korišćene baterije čuvajte van domašaja dece.
- Ako se odeljak za bateriju ne zatvori dobro, prestanite da koristite proizvod i čuvajte ga van domašaja dece.
- Ako mislite da su baterije možda progutane ili stavljene unutar bilo kog dela tela, odmah zatražite medicinsku pomoć.

OPREZ

- Rizik od eksplozije ako je baterija zamenjena nepravilnim tipom.
- Zamenite bateriju sa istim tipom.

OPREZ

- Rizik od eksplozije ili curenja zapaljive tečnosti ili gasa.
- Ne koristite/ne čuvajte/ne donosite u sredinu izuzetno visoke temperature ili izuzetno niskog pritiska usled vrlo visoke visine.
- Ne pokušavajte da zapalite, smrvite ili isečete korišćenu bateriju.

⚠ : Bu işaret bir güvenlik/uyarı işaretidir.

•Pili yutmayın.

Kimyasal Yanma Tehlikesi

- Bu üründe bir düğme pil bulunmaktadır.
- Düğme pil yutulursa, sadece 2 saat içinde ağır iç yanıklara neden olabilir ve ölüme yol açabilir.
- Yeni ve kullanılmış pilleri çocuklardan uzak tutun.
- Pil yuvası emniyetli bir şekilde kapanmıyorsa, ürünü kullanmayı bırakın ve çocuklardan uzak tutun.
- Pillerin yutulduğunu veya vücudun herhangi bir parçasının içine yerleştirildiğini düşünüyorsanız, derhal tıbbi yardım alın.

DİKKAT

- Pil yanlış tür bir pille değiştirilirse patlama riski vardır.
- Pili aynı tür pillerle değiştirin.

DİKKAT

- Patlama ya da yanıcı sıvı veya gaz sızıntısı riski vardır.

- Aşırı derecede yüksek sıcaklıktaki veya çok yüksek rakımdan dolayı aşırı derecede düşük basınca sahip ortamlarda kullanmayın /saklamayın veya bu ortamlara götürmeyin.

- Kullanılmış pili yakmaya, ezmeye veya kesmeye çalışmayın.



WARNING

■ **Caution regarding interference with electronic devices**

- People with implantable cardiac pacemakers, cardiac resynchronization therapy-pacemakers or implantable cardioverter defibrillators should maintain a reasonable distance between themselves and the smart entry & start system antennas. (→P.206)

The radio waves may affect the operation of such devices. If necessary, the entry function can be disabled. Ask a SUZUKI dealer or a qualified workshop for details, such as the frequency of radio waves and timing of the emitted radio waves. Then, consult your doctor to see if you should disable the entry function.

- User of any electrical medical device other than implantable cardiac pacemakers, cardiac resynchronization therapy-pacemakers or implantable cardioverter defibrillators should consult the manufacturer of the device for information about its operation under the influence of radio waves. Radio waves could have unexpected effects on the operation of such medical devices.

Ask a SUZUKI dealer or a qualified workshop for details for disabling the entry function.

Front seats

The seats can be adjusted (longitudinally, vertically, etc.). Adjust the seat to ensure the correct driving posture.

Adjustment procedure

- ▶ Driver's side (power seat)

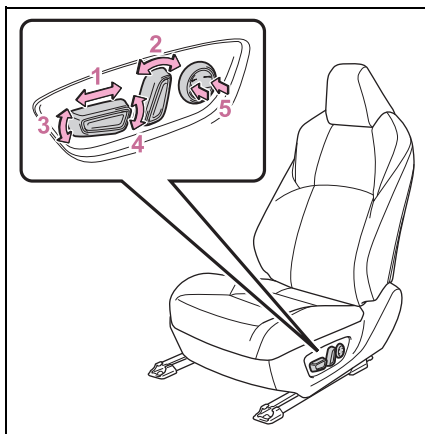

- 1 Seat position adjustment switch
- 2 Seatback angle adjustment switch
- 3 Seat cushion (front) angle adjustment switch
- 4 Vertical height adjustment switch
- 5 Lumbar support adjustment switch

- ▶ Front passenger's side (manual seat)

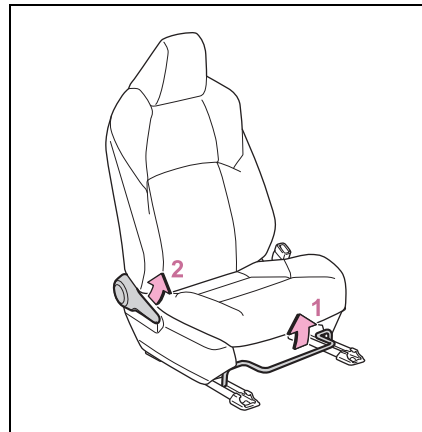

- 1 Seat position adjustment lever
- 2 Seatback angle adjustment lever

■ **When adjusting the seat**

Take care when adjusting the seat so that the head restraint does not touch the ceiling.

WARNING

■ **When adjusting the seat position**

- Take care when adjusting the seat position to ensure that other passengers are not injured by the moving seat.
- Do not put your hands under the seat or near the moving parts to avoid injury. Fingers or hands may become jammed in the seat mechanism.
- Make sure to leave enough space around the feet so they do not get stuck.
- Manual seat only: After adjusting the seat, make sure that the seat is locked in position.

! WARNING

■ Seat adjustment

To reduce the risk of sliding under the lap belt during a collision, do not recline the seat more than necessary. If the seat is too reclined, the lap belt may slide past the hips and apply restraint forces directly to the abdomen, or your neck may contact the shoulder belt, increasing the risk of death or serious injury in the event of an accident.

Adjustments should not be made while driving as the seat may unexpectedly move and cause the driver to lose control of the vehicle.

Rear seats

Reclining adjustments and folding the seatbacks can be done with lever operation.

Adjustment procedure

Pull the seatback angle adjustment lever **A**, and adjust the seatback angle.

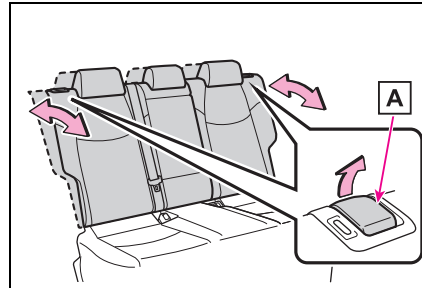

! WARNING

■ When operating the seatback

Observe the following precautions. Failure to do so may cause death or serious injury.

- Keep other passengers from being hit with the seatback.
- Do not bring your hands close to the moving parts or between the seats, as well as do not let any part of your body get caught.

! WARNING

- After adjusting the seat, make sure that the seat is locked in position. If the seatback is not securely locked, the red marking will be visible. Make sure that the red marking is not visible.

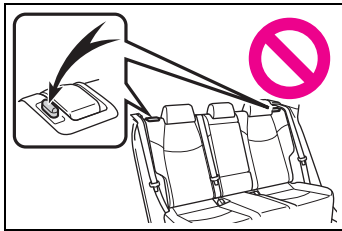

Folding down the rear seatbacks

■ **Before folding down the seatbacks**

- 1 Park the vehicle in a safe place. Apply the parking brake (→P.288) and shift the shift lever to P. (→P.284)
- 2 Adjust the position of the front seat and the angle of the seatback. (→P.249)

Depending on the position of the front seat, if the seatback is folded backward, it may interfere with the operation of the rear seat.

- 3 Lower the head restraint of the rear seat. (→P.252)
- 4 Stow the armrest of the rear seat if it is pulled out. (→P.429)

This step is not necessary when operating the left side seat only.

■ **Folding down the seatbacks**

While pulling the seatback angle adjustment lever **A**, fold the seatback down.

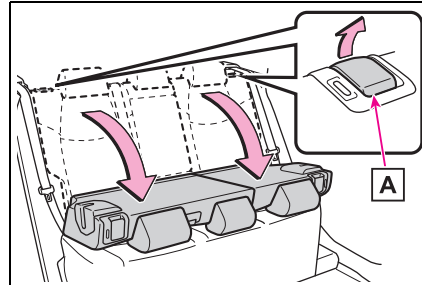

■ **Returning the rear seatbacks**

To avoid trapping the seat belt between the seat and the inside of the vehicle, pass the seat belt outside the seat belt guide **A** and then return the seatback securely to the locked position.

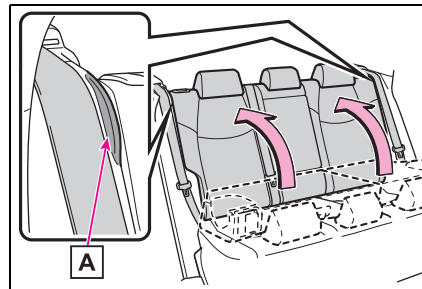

! WARNING

Observe the following precautions. Failure to do so may result in death or serious injury.

■ **When folding the rear seatbacks down**

- Do not fold the seatbacks down while driving.
- Stop the vehicle on level ground, set the parking brake and shift the shift lever to P.
- Do not allow anyone to sit on a folded seatback or in the luggage compartment while driving.

! WARNING

- Do not allow children to enter the luggage compartment.
- Do not operate the rear seat if it is occupied.
- Be careful not to get feet or hands caught in the moving parts or joints of the seats during operation.
- Do not allow children to operate the seat.
- **After returning the rear seatback to the upright position**
- Make sure that the seatback is securely locked in position by lightly pushing it back and forth. If the seatback is not securely locked, the red marking will be visible. Make sure that the red marking is not visible.

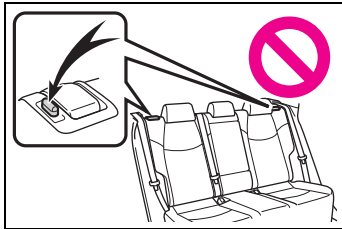

- Check that the seat belts are not twisted or caught in the seatback.

Head restraints

Head restraints are provided for all seats.

! WARNING

■ **Head restraint precautions**

Observe the following precautions regarding the head restraints. Failure to do so may result in death or serious injury.

- Use the head restraints designed for each respective seat.
- Adjust the head restraints to the correct position at all times.
- After adjusting the head restraints, push down on them and make sure they are locked in position.
- Do not drive with the head restraints removed.

Vertical adjustment

■ **Front seats**

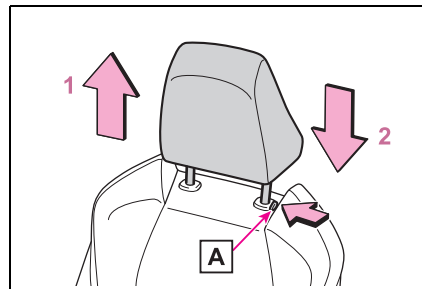

1 Up

Pull the head restraints up.

2 Down

Push the head restraint down while pressing the lock release button **A**.

■ **Rear seats**

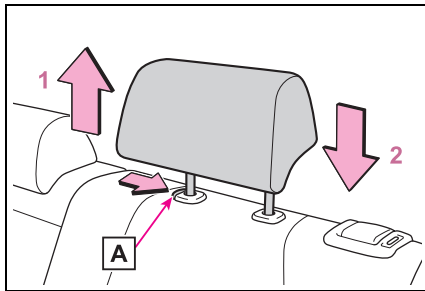

- 1 Up**
Pull the head restraints up.
- 2 Down**
Push the head restraint down while pressing the lock release button **A**.

■ **Adjusting the height of the head restraints (front seats)**

Make sure that the head restraints are adjusted so that the center of the head restraint is closest to the top of your ears.

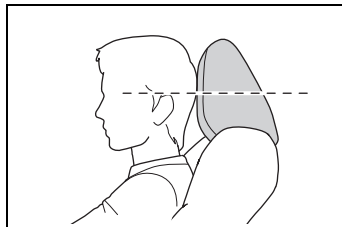

■ **Adjusting the rear seat head restraint**

Always raise the head restraint one level from the stowed position when using.

Removing the head restraints

Pull the head restraint up while pressing the lock release button **A**.

If the head restraint touches the ceiling, making the removal difficult, change the seat height or angle. (→P.249)

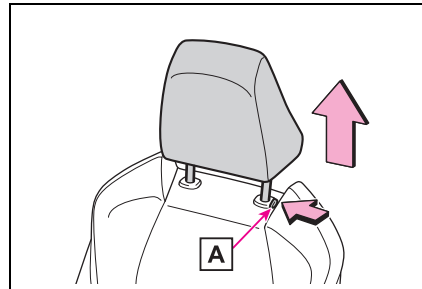

Installing the head restraints

Align the head restraint with the installation holes and push it down to the lock position.

Press and hold the lock release button **A** when lowering the head restraint.

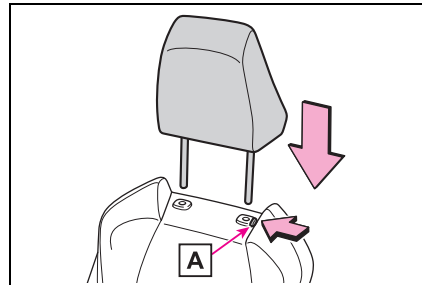

4

Before driving

Steering wheel

Adjustment procedure

- 1 Hold the steering wheel and push the lever down.

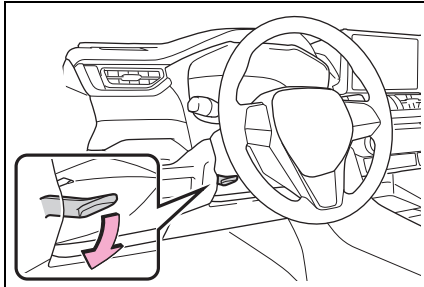

- 2 Adjust to the ideal position by moving the steering wheel horizontally and vertically.

After adjustment, pull the lever up to secure the steering wheel.

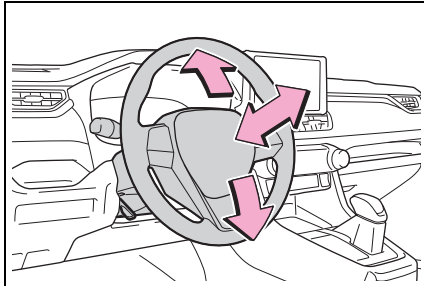

WARNING

■ Caution while driving

Do not adjust the steering wheel while driving. Doing so may cause the driver to mishandle the vehicle and cause an accident, resulting in death or serious injury.

■ After adjusting the steering wheel

Make sure that the steering wheel is securely locked. Otherwise, the steering wheel may move suddenly, possibly causing an accident, and resulting in death or serious injury. Also, the horn may not sound if the steering wheel is not securely locked.

Sounding the horn

To sound the horn, press on or close to the  mark.

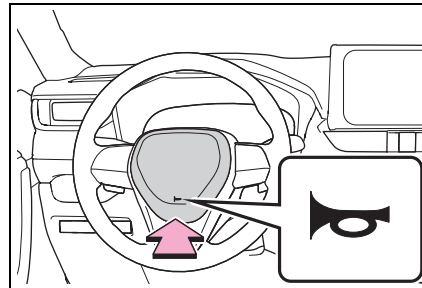

Inside rear view mirror

The rear view mirror's position can be adjusted to enable sufficient confirmation of the rear view.

Adjusting the height of rear view mirror

The height of the rear view mirror can be adjusted to suit your driving posture.

Adjust the height of the rear view mirror by moving it up and down.

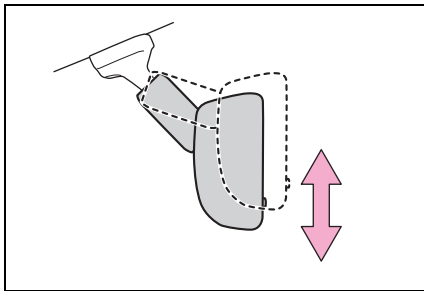

WARNING

■ Caution while driving

Do not adjust the position of the mirror while driving. Doing so may lead to mishandling of the vehicle and cause an accident, resulting in death or serious injury.

Anti-glare function

Responding to the level of brightness of the headlights of vehicles behind, the reflected light is automatically reduced.

Changing automatic anti-glare

function mode on/off

When the automatic anti-glare function is in ON mode, the indicator **A** illuminates.

The function will set to ON mode each time the power switch is turned to ON. Pressing the button turns the function to OFF mode. (The indicator **A** also turns off.)

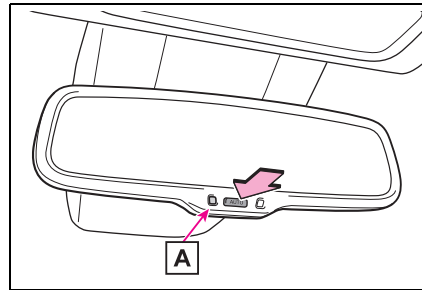

■ To prevent sensor error

To ensure that the sensors operate properly, do not touch or cover them.

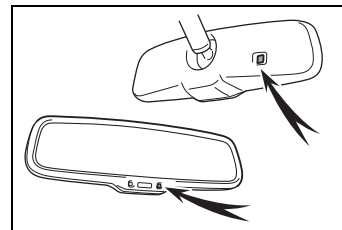

Outside rear view mirrors

The rear view mirror's position can be adjusted to enable sufficient confirmation of the rear view.

Defogging the mirrors

The outside rear view mirrors can be cleared using the mirror defoggers. Turn on the rear window defogger to turn on the outside rear view mirror defoggers. (→P.408)

WARNING

Important points while driving

Observe the following precautions while driving. Failing to do so may result in loss of control of the vehicle and cause an accident, resulting in death or serious injury.

- Do not adjust the mirrors while driving.
- Do not drive with the mirrors folded.
- Both the driver and passenger side mirrors must be extended and properly adjusted before driving.

When the mirror defoggers are operating

Do not touch the rear view mirror surfaces, as they can become very hot and burn you.

Adjustment procedure

- 1 To select a mirror to adjust, press the switch.

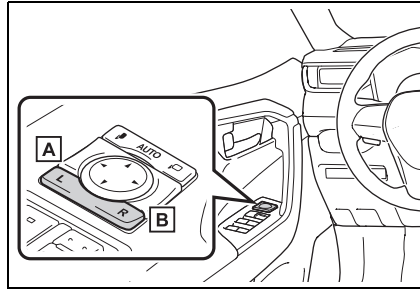

A Left

B Right

- 2 To adjust the mirror, press the switch.

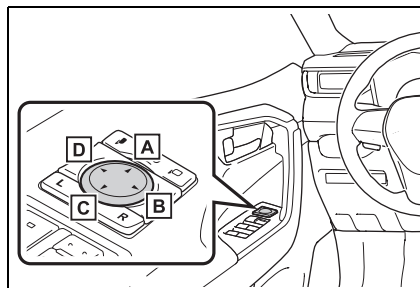

A Up

B Right

C Down

D Left

Mirror angle can be adjusted when

The power switch is in ACC or ON.

Folding the mirrors

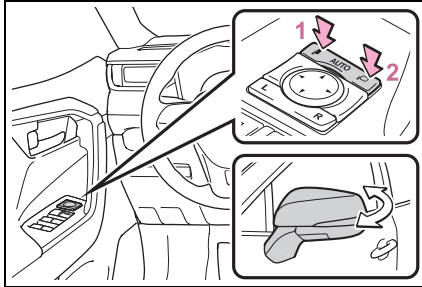

- 1 Folds the mirrors
- 2 Extends the mirrors

Putting the outside rear view mirror folding switch in the neutral position sets the mirrors to automatic mode. Automatic mode allows the folding or extending of the mirrors to be linked to locking/unlocking of the doors.

■ Using automatic mode in cold weather

When automatic mode is used in cold weather, the door mirror could freeze up and automatic stowing and return may not be possible. In this event, remove any ice and snow from the door mirror, then either operate the mirror using manual mode or move the mirror by hand.

■ Customization

The automatic mirror folding and extending operation can be changed. (Customizable features: →P.560)

WARNING

■ When a mirror is moving

To avoid personal injury and mirror malfunction, be careful not to get your hand caught by the moving mirror.

Power windows

Opening and closing the power windows

The power windows can be opened and closed using the switches. Operating the switch moves the side windows as follows:

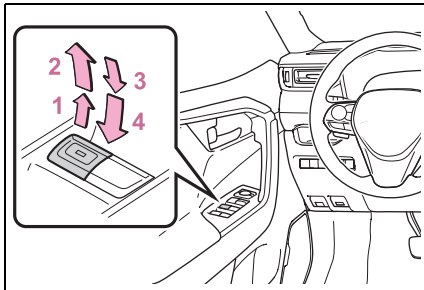

- 1 Closing
- 2 One-touch closing*
- 3 Opening
- 4 One-touch opening*

*: To stop the side window partway, operate the switch in the opposite direction.

■ The power windows can be operated when

The power switch is in ON.

■ Operating the power windows after turning the hybrid system off

The power windows can be operated for approximately 45 seconds even after the power switch is turned to ACC or OFF. They cannot, however, be operated once either front door is opened.

■ Jam protection function

If an object becomes jammed between the side window and the window frame while the side window is closing, side

window movement is stopped and the side window is opened slightly.

■ Catch protection function

If an object becomes caught between the door and side window while the side window is opening, side window movement is stopped.

■ When the power window cannot be opened or closed

When the jam protection function or catch protection function operates unusually and the side window cannot be opened and closed, perform the following operations with the power window switch of that door.

- Stop the vehicle. With the power switch in ON, within 4 seconds of the jam protection function or catch protection function activating, continuously operate the power window switch in the one-touch closing direction or one-touch opening direction so that the side window can be opened and closed.
- If the side window cannot be opened and closed even when performing the above operations, perform the following procedure for function initialization.

- 1 Turn the power switch to ON.
- 2 Pull and hold the power window switch in the one-touch closing direction and completely close the side window.
- 3 Release the power window switch for a moment, resume pulling the switch in the one-touch closing direction, and hold it there for approximately 6 seconds or more.
- 4 Press and hold the power window switch in the one-touch opening direction. After the side window is completely opened, continue holding the switch for an additional 1 second or more.
- 5 Release the power window switch for a moment, resume pushing the switch in the one-touch opening

direction, and hold it there for approximately 4 seconds or more.

- 6 Pull and hold the power window switch in the one-touch closing direction again. After the side window is completely closed, continue holding the switch for a further 1 second or more.

If you release the switch while the side window is moving, start again from the beginning.

If the side window reverses and cannot be fully closed or opened, have the vehicle inspected by a SUZUKI dealer or a qualified workshop.

■ Door lock linked power window operation

- The power windows can be opened and closed using the mechanical key.* (→P.533)
- The power windows can be opened and closed using the wireless remote control.* (→P.191)
- The alarm may be triggered if the alarm is set and the power window is closed using the door lock linked power window operation function. (→P.73)

*: These settings must be customized at a SUZUKI dealer or a qualified workshop.

■ Power window open reminder function

The buzzer sounds and a message is shown on the multi-information display when the power switch is turned to OFF and the driver's door is opened with the power windows open.

■ Customization

Settings (e.g. linked door lock operation) can be changed. (Customizable features: →P.561)

⚠ WARNING

Observe the following precautions. Failing to do so may result in death or serious injury.

■ Closing the power windows

- The driver is responsible for all the power window operations, including the operation for the passengers. In order to prevent accidental operation, especially by a child, do not let a child operate the power windows. It is possible for children and other passengers to have body parts caught in the power window. Also, when riding with a child, it is recommended to use the window lock switch. (→P.260)
- Check to make sure that all passengers do not have any part of their body in a position where it could be caught when a power window is being operated.

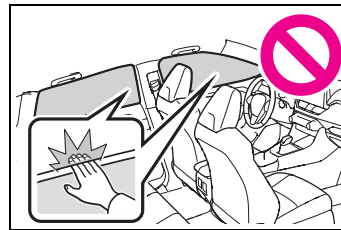

- When using the wireless remote control or mechanical key and operating the power windows, operate the power window after checking to make sure that there is no possibility of any passenger having any of their body parts caught in the side window. Also, do not let a child operate the power window by the wireless remote control or mechanical key. It is possible for children and other passengers to get caught in the power window.

⚠ WARNING

- When exiting the vehicle, turn the power switch to OFF, carry the key and exit the vehicle along with the child. There may be accidental operation, due to mischief, etc., that may possibly lead to an accident.

■ **Jam protection function**

- Never use any part of your body to intentionally activate the jam protection function.
- The jam protection function may not work if something gets jammed just before the side window is fully closed. Be careful not to get any part of your body jammed in the side window.

■ **Catch protection function**

- Never use any part of your body or clothing to intentionally activate the catch protection function.
- The catch protection function may not work if something gets caught just before the side window is fully opened. Be careful not to get any part of your body or clothing caught in the side window.

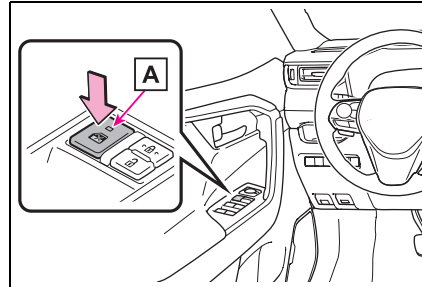

■ **The window lock switch can be operated when**

The power switch is in ON.

■ **When the 12-volt battery is disconnected**

The window lock switch is disabled. If necessary, press the window lock switch after reconnecting the 12-volt battery.

Preventing accidental operation (window lock switch)

This function can be used to prevent children from accidentally opening or closing a passenger window.

Press the switch.

The indicator **A** will come on and the passenger windows will be locked.

The passenger windows can still be opened and closed using the driver's switch even if the lock switch is on.

- 5-1. Before driving**
 - Driving the vehicle**262**
 - Cargo and luggage**268**
 - Trailer towing**270**
- 5-2. Driving procedures**
 - Power (ignition) switch.....**279**
 - Hybrid transmission**283**
 - Turn signal lever**287**
 - Parking brake**288**
 - Brake Hold.....**291**
- 5-3. Operating the lights and wipers**
 - Headlight switch**294**
 - AHB (Automatic High Beam)
.....**296**
 - Fog light switch.....**299**
 - Windshield wipers and washer
.....**300**
 - Rear window wiper and washer
.....**302**
- 5-4. Refueling**
 - Opening the fuel tank cap.**304**
- 5-5. Using the driving support systems**
 - Safety Sense**306**
 - PCS (Pre-Collision System)
.....**316**
 - LTA (Lane Tracing Assist) .**323**
 - RSA (Road Sign Assist)....**333**
 - Dynamic radar cruise control
with full-speed range**337**
 - BSM (Blind Spot Monitor) .**349**
 - Parking assist-sensor**369**
 - PKSB (Parking Support Brake)
.....**375**
 - Parking Support Brake function
(static objects)**379**
 - Parking Support Brake function
(rear-crossing vehicles) ..**384**
 - Driving mode select switch**388**
 - Trail Mode.....**390**
 - GPF (Gasoline Particulate Filter)
system.....**391**
 - Driving assist systems**392**
- 5-6. Driving tips**
 - Winter driving tips**399**
 - Utility vehicle precautions .**401**

Driving the vehicle

The following procedures should be observed to ensure safe driving:

Driving procedure

■ Before starting the hybrid system

Check that the charging cable is disconnected. (→P.128)

■ Starting the hybrid system

→P.279

■ Driving

- 1 With the brake pedal depressed, shift the shift lever to D. (→P.283)
- 2 Release the parking brake. (→P.288)

If the parking brake is in automatic mode, the parking brake is released automatically when shifting the shift lever to any position other than P. (→P.289)

- 3 Gradually release the brake pedal and gently depress the accelerator pedal to accelerate the vehicle.

■ Stopping

- 1 With the shift lever in D, depress the brake pedal.
- 2 If necessary, set the parking brake. (→P.288)

If the vehicle is to be stopped for an extended period of time, shift the shift lever to P. (→P.283)

■ Parking the vehicle

- 1 With the shift lever in D, depress the brake pedal.
- 2 Set the parking brake (→P.288), and shift the shift lever to P. (→P.283)
- 3 Turn the power switch to OFF to stop the hybrid system.
- 4 Lock the door, making sure that you have the key on your person.

If parking on a hill, block the wheels as needed.

■ Starting off on a steep uphill

- 1 With the brake pedal depressed, shift the shift lever to D. (→P.283)
- 2 Pull the parking brake switch to set the parking brake manually. (→P.288)
- 3 Release the brake pedal and gently depress the accelerator pedal to accelerate the vehicle.

Parking brake automatic release function (→P.289)

■ When starting off on a uphill

The hill-start assist control will activate. (→P.393)

■ For electricity-saving and fuel-efficient driving

Understand the system characteristics of the vehicle to use the functions of the hybrid system. Also, keep in mind that hybrid vehicles are similar to conventional vehicles, and it is necessary to refrain from activities such as sudden acceleration. Refer to "Plug-in hybrid vehicle driving tips" (→P.93).

■ Driving in the rain

- Drive carefully when it is raining, because visibility will be reduced, the windows may become fogged-up, and the road could be slippery.
- Drive carefully when it starts to rain, as the road surface could be especially slippery.
- Refrain from high speeds when driving on an expressway in the rain, because there may be a layer of water between the tires and the road surface, preventing the steering and brakes from operating properly.

■ ECO Accelerator Guidance (→P.174)

It is easier to drive in an Eco-friendly manner by driving while referring to the ECO Accelerator Guidance display. Also, by using the ECO Accelerator Guidance it is easier to increase the "Eco Score" evaluation.

- When starting off: While staying within the ECO Accelerator Guidance range, gradually depress the accelerator pedal and accelerate to the desired speed. If excessive acceleration is avoided, the "Start" score will increase.
- When driving: After accelerating to the desired speed, release the accelerator pedal and drive at a stable speed within the ECO Accelerator Guidance range. By keeping the vehicle within the ECO Accelerator Guidance range, the "Cruise" score will increase.
- When stopping: When stopping the vehicle, early releasing the accelerator pedal will cause the "Stop" score to increase.

■ Restraining the hybrid system output (Brake Override System)

- When the accelerator and brake pedals are depressed at the same time, the hybrid system output may be restrained.
- A warning message is displayed on the multi-information display while the

system is operating. (→P.514)

■ Restraining sudden start (Drive-Start Control)

- When the following unusual operation is performed, the hybrid system output may be restrained.
 - When the shift lever is shifted from R to D, D to R, N to R, P to D*, or P to R* (D includes S) with the accelerator pedal depressed, a warning message appears on the multi-information display. If a warning message is shown on the multi-information display, read the message and follow the instructions.
 - When the accelerator pedal is depressed too much while the vehicle is in reverse.

*: Depending on the situation, the shift lever may not be changed.

- While Drive-Start Control is being activated, your vehicle may have trouble escaping from the mud or fresh snow. In such case, deactivate TRC (→P.394) to cancel Drive-Start Control so that the vehicle may be able to escape from the mud or fresh snow.
- Drive-Start Control does not work when Trail Mode is turned on.

■ Breaking in your new Suzuki

To extend the life of the vehicle, observing the following precautions is recommended:

- For the first 300 km (200 miles): Avoid sudden stops.
- For the first 800 km (500 miles): Do not tow a trailer.
- For the first 1000 km (600 miles):
 - Do not drive at extremely high speeds.
 - Avoid sudden acceleration.
 - Do not drive continuously in low gears.
 - Do not drive at a constant speed for extended periods.

■ Operating your vehicle in a foreign country

Comply with the relevant vehicle registration laws and confirm the availability of the correct fuel. (→P.548)



WARNING

Observe the following precautions. Failure to do so may result in death or serious injury.

■ When starting the vehicle

Always keep your foot on the brake pedal while stopped with the "READY" indicator is illuminated. This prevents the vehicle from creeping.

■ When driving the vehicle

- Do not drive if you are unfamiliar with the location of the brake and accelerator pedals to avoid depressing the wrong pedal.
- Accidentally depressing the accelerator pedal instead of the brake pedal will result in sudden acceleration that may lead to an accident.
- When backing up, you may twist your body around, leading to a difficulty in operating the pedals. Make sure to operate the pedals properly.
- Make sure to keep a correct driving posture even when moving the vehicle only slightly. This allows you to depress the brake and accelerator pedals properly.
- Depress the brake pedal using your right foot. Depressing the brake pedal using your left foot may delay response in an emergency, resulting in an accident.

- The driver should pay extra attention to pedestrians when the vehicle is powered only by the electric motor (traction motor). As there is no engine noise, the pedestrians may misjudge the vehicle's movement. Even though the vehicle is equipped with the Acoustic Vehicle Alerting System, drive with care as pedestrians in the vicinity may still not notice the vehicle if the surrounding area is noisy.

- Do not drive the vehicle over or stop the vehicle near flammable materials such as leaves, paper or rags. The exhaust system and exhaust gases can be extremely hot. These hot parts may cause a fire if there is any flammable material nearby.

- During normal driving, do not turn off the hybrid system. Turning the hybrid system off while driving will not cause loss of steering or braking control, however, power assist to the steering will be lost. This will make it more difficult to steer smoothly, so you should pull over and stop the vehicle as soon as it is safe to do so. In the event of an emergency, such as if it becomes impossible to stop the vehicle in the normal way: →P.500

- Use engine braking (downshift) to maintain a safe speed when driving down a steep hill. Using the brakes continuously may cause the brakes to overheat and lose effectiveness. (→P.283)

- Do not adjust the position of the steering wheel, the seat, or the inside or outside rear view mirrors while driving. Doing so may result in a loss of vehicle control.

**WARNING**

- Always check that all passengers' arms, head or other parts of their body are not outside the vehicle.
- **When driving on slippery road surfaces**
- Sudden braking, acceleration and steering may cause tire slippage and reduce your ability to control the vehicle.
- Sudden acceleration, engine braking due to shifting, or changes in engine speed could cause the vehicle to skid.
- After driving through a puddle, lightly depress the brake pedal to make sure that the brakes are functioning properly. Wet brake pads may prevent the brakes from functioning properly. If the brakes on only one side are wet and not functioning properly, steering control may be affected.
- **When shifting the shift lever**
- Do not let the vehicle roll backward while a forward driving position is selected, or roll forward while the shift lever is in R. Doing so may result in an accident or damage to the vehicle.
- Do not shift the shift lever to P while the vehicle is moving. Doing so can damage the transmission and may result in a loss of vehicle control.
- Do not shift the shift lever to R while the vehicle is moving forward. Doing so can damage the transmission and may result in a loss of vehicle control.

- Do not shift the shift lever to a driving position while the vehicle is moving backward. Doing so can damage the transmission and may result in a loss of vehicle control.
- Moving the shift lever to N while the vehicle is moving will disengage the hybrid system. Engine braking is not available with the hybrid system disengaged.
- Be careful not to shift the shift lever with the accelerator pedal depressed. Shifting the shift lever to a gear other than P or N may lead to unexpected rapid acceleration of the vehicle that may cause an accident and result in death or serious injury. Doing so can damage the transmission and may result in a loss of vehicle control.
- **If you hear a squealing or scraping noise (brake pad wear indicators)**
- Have the brake pads checked and replaced by a SUZUKI dealer or a qualified workshop as soon as possible. Rotor damage may result if the pads are not replaced when needed. It is dangerous to drive the vehicle when the wear limits of the brake pads and/or those of the brake discs are exceeded.
- **When the vehicle is stopped**
- Do not depress the accelerator pedal unnecessarily. If the vehicle is in any gear other than P or N, the vehicle may accelerate suddenly and unexpectedly, causing an accident.
- In order to prevent accidents due to the vehicle rolling away, always keep depressing the brake pedal while stopped with the "READY" indicator is illuminated, and apply the parking brake as necessary.

**WARNING**

- If the vehicle is stopped on an incline, in order to prevent accidents caused by the vehicle rolling forward or backward, always depress the brake pedal and securely apply the parking brake as needed.
- Avoid revving or racing the engine. Running the engine at high speed while the vehicle is stopped may cause the exhaust system to overheat, which could result in a fire if combustible material is nearby.
- **When the vehicle is parked**
 - Do not leave glasses, cigarette lighters, spray cans, or soft drink cans in the vehicle when it is in the sun. Doing so may result in the following:
 - Gas may leak from a cigarette lighter or spray can, and may lead to a fire.
 - The temperature inside the vehicle may cause the plastic lenses and plastic material of glasses to deform or crack.
 - Soft drink cans may fracture, causing the contents to spray over the interior of the vehicle, and may also cause a short circuit in the vehicle's electrical components.
 - Do not leave cigarette lighters in the vehicle. If a cigarette lighter is in a place such as the glove box or on the floor, it may be lit accidentally when luggage is loaded or the seat is adjusted, causing a fire.
 - Do not attach adhesive discs to the windshield or windows. Do not place containers such as air fresheners on the instrument panel or dashboard. Adhesive discs or containers may act as lenses, causing a fire in the vehicle.

- Do not leave a door or window open if the curved glass is coated with a metallized film such as a silver-colored one. Reflected sunlight may cause the glass to act as a lens, causing a fire.
- Always apply the parking brake, shift the shift lever to P, stop the hybrid system and lock the vehicle. Do not leave the vehicle unattended while the "READY" indicator is illuminated. If the vehicle is parked with the shift lever in P but the parking brake is not set, the vehicle may start to move, possibly leading to an accident.
- Do not touch the exhaust pipes while the "READY" indicator is illuminated or immediately after turning the hybrid system off. Doing so may cause burns.

■ **When taking a nap in the vehicle**

Always turn the hybrid system off. Otherwise, if you accidentally move the shift lever or depress the accelerator pedal, this could cause an accident or fire due to hybrid system overheating. Additionally, if the vehicle is parked in a poorly ventilated area, exhaust gases may collect and enter the vehicle, leading to death or a serious health hazard.

■ **When braking**

- When the brakes are wet, drive more cautiously. Braking distance increases when the brakes are wet, and this may cause one side of the vehicle to brake differently than the other side. Also, the parking brake may not securely hold the vehicle.

**WARNING**

- If the electronically controlled brake system does not operate, do not follow other vehicles closely and avoid hills or sharp turns that require braking.
In this case, braking is still possible, but the brake pedal should be depressed more firmly than usual. Also, the braking distance will increase. Have your brakes fixed immediately.
- The brake system consists of 2 or more individual hydraulic systems; if one of the systems fails, the other will still operate. In this case, the brake pedal should be depressed more firmly than usual and the braking distance will increase. Have your brakes fixed immediately.

■ If the vehicle becomes stuck

Do not spin the wheels excessively when any of the tires is up in the air, or the vehicle is stuck in sand, mud, etc. This may damage the driveline components or propel the vehicle forward or backward, causing an accident.

**NOTICE****■ When driving the vehicle**

- Do not depress the accelerator and brake pedals at the same time during driving, as this may restrain the hybrid system output.
- Do not use the accelerator pedal or depress the accelerator and brake pedals at the same time to hold the vehicle on a hill.

■ Avoiding damage to vehicle parts

- Do not turn the steering wheel fully in either direction and hold it there for an extended period of time. Doing so may damage the power steering motor.

- When driving over bumps in the road, drive as slowly as possible to avoid damaging the wheels, underside of the vehicle, etc.

■ If you get a flat tire while driving

A flat or damaged tire may cause the following situations.

- It may be difficult to control your vehicle.
- The vehicle will make abnormal sounds or vibrations.
- The vehicle will lean abnormally.

Hold the steering wheel firmly and gradually depress the brake pedal to slow down the vehicle.

Information on what to do in case of a flat tire (→P.522)

■ When encountering flooded roads

Do not drive on a road that has flooded after heavy rain, etc. Doing so may cause the following serious damage to the vehicle:

- Engine stalling
- Short in electrical components
- Engine damage caused by water immersion

In the event that you drive on a flooded road and the vehicle is flooded, be sure to have a SUZUKI dealer or a qualified workshop check the following:

- Brake function
- Changes in quantity and quality of oil and fluid used for the engine, hybrid transaxle (front and rear), etc.
- Lubricant condition for the bearings and suspension joints (where possible), and the function of all joints, bearings, etc.



NOTICE

■ When parking the vehicle

Always set the parking brake, and shift the shift lever to P. Failure to do so may cause the vehicle to move or the vehicle may accelerate suddenly if the accelerator pedal is accidentally depressed.

Cargo and luggage**Take notice of the following information about storage precautions, cargo capacity and load.**

WARNING

■ Things that must not be carried in the luggage compartment

The following things may cause a fire if loaded in the luggage compartment:

- Receptacles containing gasoline
- Aerosol cans

■ Storage precautions

Observe the following precautions. Failure to do so may prevent the pedals from being depressed properly, may block the driver's vision, or may result in items hitting the driver or passengers, possibly causing an accident.

- Stow cargo and luggage in the luggage compartment whenever possible.
- Do not stack anything in the luggage compartment higher than the seatbacks.
- When you fold down the rear seats, long items should not be placed directly behind the front seats.
- Never allow anyone to ride in the luggage compartment. It is not designed for passengers. They should ride in their seats with their seat belts properly fastened. Otherwise, they are much more likely to suffer death or serious bodily injury, in the event of sudden braking, sudden swerving or an accident.

**WARNING**

- Do not place cargo or luggage in or on the following locations.
 - At the feet of the driver
 - On the front passenger or rear seats (when stacking items)
 - On the luggage cover
 - On the instrument panel
 - On the dashboard

- Secure all items in the occupant compartment.

■ Load and distribution

- Do not overload your vehicle.

- Do not apply loads unevenly.

Improper loading may cause deterioration of steering or braking control which may cause death or serious injury.

■ When loading cargo on the roof luggage carrier (if equipped)

Observe the following precautions:

- Place the cargo so that its weight is distributed evenly between the front and rear axles.
- If loading long or wide cargo, never exceed the vehicle overall length or width. (→P.546)
- Before driving, make sure the cargo is securely fastened on the roof luggage carrier.
- Loading cargo on the roof luggage carrier will make the center of gravity of the vehicle higher. Avoid high speeds, sudden starts, sharp turns, sudden braking or abrupt maneuvers, otherwise it may result in loss of control or vehicle rollover due to failure to operate this vehicle correctly and result in death or serious injury.

- If driving for a long distance, on rough roads, or at high speeds, stop the vehicle now and then during the trip to make sure the cargo remains in its place.

- Do not exceed 80 kg (176.4 lb.) cargo weight on the roof luggage carrier.

Trailer towing

Your vehicle is designed primarily as a passenger carrying vehicle. Towing a trailer will have an adverse effect on handling, performance, braking, durability, and fuel consumption. Your safety and satisfaction depend on the proper use of correct equipment and cautious driving habits. For your safety and the safety of others, do not overload the vehicle or trailer.

To tow a trailer safely, use extreme care and drive the vehicle in accordance with the trailer's characteristics and operating conditions.

Suzuki warranties do not apply to damage or malfunction caused by towing a trailer for commercial purposes.

Ask your local authorized SUZUKI dealer or a qualified workshop for further details before towing, as there are additional legal requirements in some countries.

■ Tire information

- Increase the tire inflation pressure to 20.0 kPa (0.2 kgf/cm² or bar, 3 psi) greater than the recommended value when towing. (→P.552)
- Increase the air pressure of the trailer tires in accordance with the total trailer weight and according to the val-

ues recommended by the manufacturer of your trailer.

■ Safety checks before towing

- Check that the maximum load limit for the towing hitch/bracket and hitch ball is not exceeded. Bear in mind that the coupling weight of the trailer will add to the load exerted on the vehicle. Also make sure that the total load exerted on the vehicle is within the range of the weight limits. (→P.271)
- Ensure that the trailer load is secure.
- Supplementary outside rear view mirrors should be added to the vehicle if the traffic behind cannot be clearly seen with standard mirrors. Adjust the extending arms of these mirrors on both sides of the vehicle so that they always provide maximum visibility of the road behind.



WARNING

Follow all the instructions described in this section.

Failure to do so could cause an accident resulting in death or serious injury.

■ Trailer towing precautions

When towing, make sure that none of the weight limits are exceeded. (→P.271)

■ To avoid accident or injury

- Do not tow a trailer when the compact spare tire is installed on your vehicle.
- Do not use dynamic radar cruise control with full-speed range when trailer towing.

■ Vehicle speed in towing

Observe the legal maximum speeds for trailer towing.

⚠ WARNING**■ Before descending hills or long declines**

Reduce speed and downshift. However, never downshift suddenly while descending steep or long downhill grades.

■ Operation of the brake pedal

Do not hold the brake pedal depressed often or for long periods of time.

Doing so may result in the brake overheating or reduce braking effects.

Weight limits

Check the allowable towing capacity, GVM (Gross Vehicle Mass), MPAC (Maximum Permissible Axle Capacity), and permissible drawbar load before towing. (→P.546)

Towing hitch/bracket

Suzuki recommends the use of the Suzuki hitch/bracket for your vehicle. Other products of a suitable nature and comparable quality may also be used.

For vehicles where the towing device blocks any of the lights or license plate, the following shall be observed:

- Do not use towing device that cannot be easily removed or repositioned.
- Towing devices must be removed or repositioned when not in use.

Connecting trailer lights

Please consult a SUZUKI dealer or a qualified workshop when installing trailer lights, as incorrect installation may cause damage to the vehicle's lights. Please take care to comply with your state's laws when installing trailer lights.

⚠ NOTICE**■ Do not directly splice trailer lights**

Directly splicing trailer lights may damage your vehicle's electrical system and cause a malfunction.

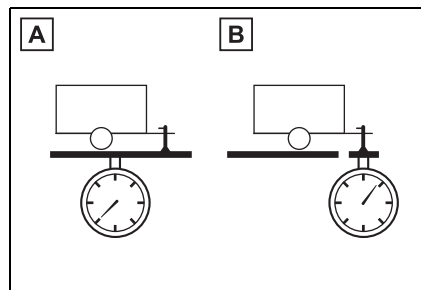
Important points regarding trailer loads**■ Total trailer weight and permissible drawbar load****A Total trailer weight**

Weight of the trailer itself plus the trailer load should be within the maximum towing capacity. Exceeding this weight is dangerous. (→P.546)

When towing a trailer, use a friction coupler or friction stabilizer (sway control device).

B Permissible drawbar load

Allocate the trailer load so that the drawbar load is greater than 25 kg (55.1 lb.) or 4% of the towing capacity. Do not let the drawbar load exceed the indicated weight. (→P.546)

■ **Information tag (manufacturer's label)**

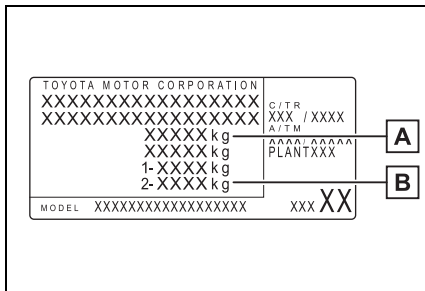

A Gross vehicle mass

The combined weight of the driver, passengers, luggage, towing hitch, total curb mass and drawbar load should not exceed the gross vehicle mass by more than 100 kg (220.5 lb.). Exceeding this weight is dangerous.

B Maximum permissible rear axle capacity

The weight borne by the rear axle should not exceed the maximum permissible rear axle capacity by 15% or more. Exceeding this weight is dangerous.

The values for towing capacity were derived from testing conducted at sea level. Take note that hybrid system output and towing capacity will be reduced at high altitudes.

! WARNING

■ **When the gross vehicle mass or maximum permissible axle capacity is exceeded**

Failing to observe this precaution may lead to an accident causing death or serious injury.

- Add an additional 20.0 kPa (0.2 kgf/cm² or bar, 3 psi) to the recommended tire inflation pressure value. (→P.552)
- Do not exceed the established speed limit for towing a trailer in built-up areas or 100 km/h (62 mph), whichever is lower.

Installation positions for the towing hitch/bracket and hitch ball

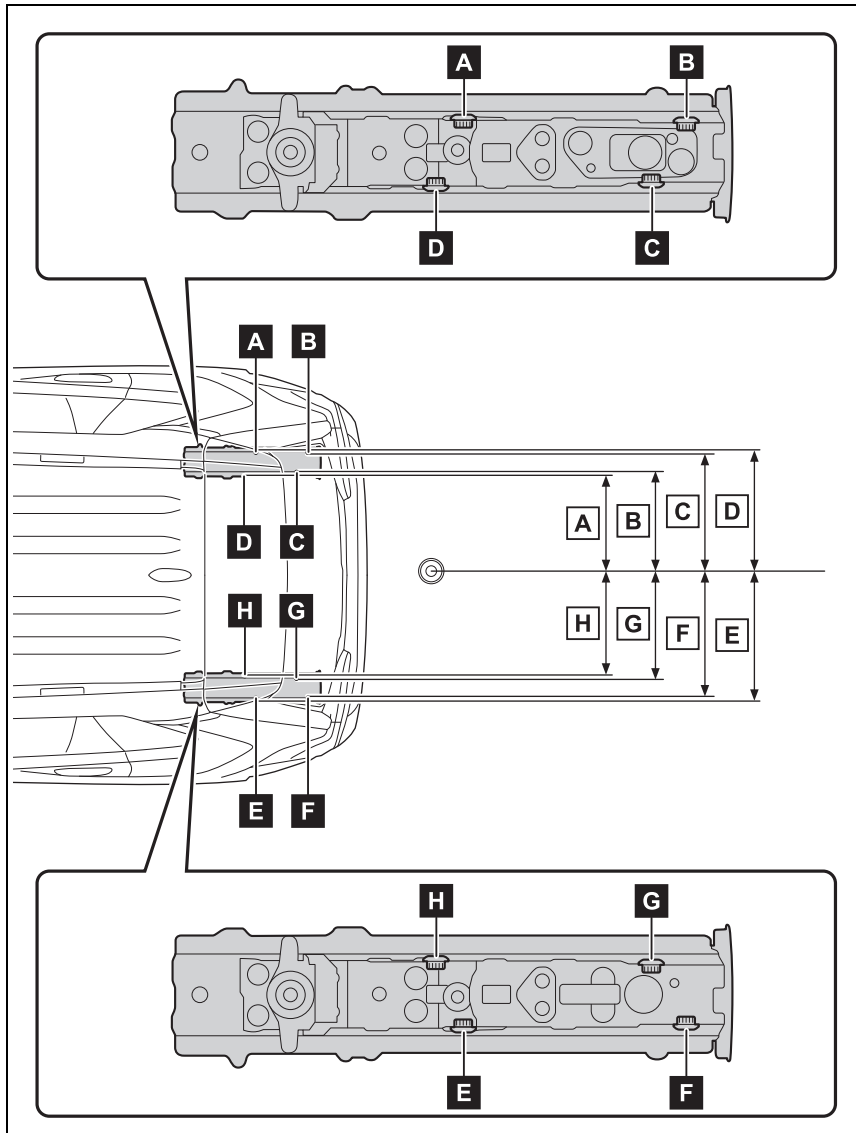

A 458 mm (18.0 in.)

B 461 mm (18.1 in.)

C 536 mm (21.1 in.)

D 537 mm (21.1 in.)

E 537 mm (21.1 in.)

F 536 mm (21.1 in.)

G 461 mm (18.1 in.)

H 458 mm (18.0 in.)

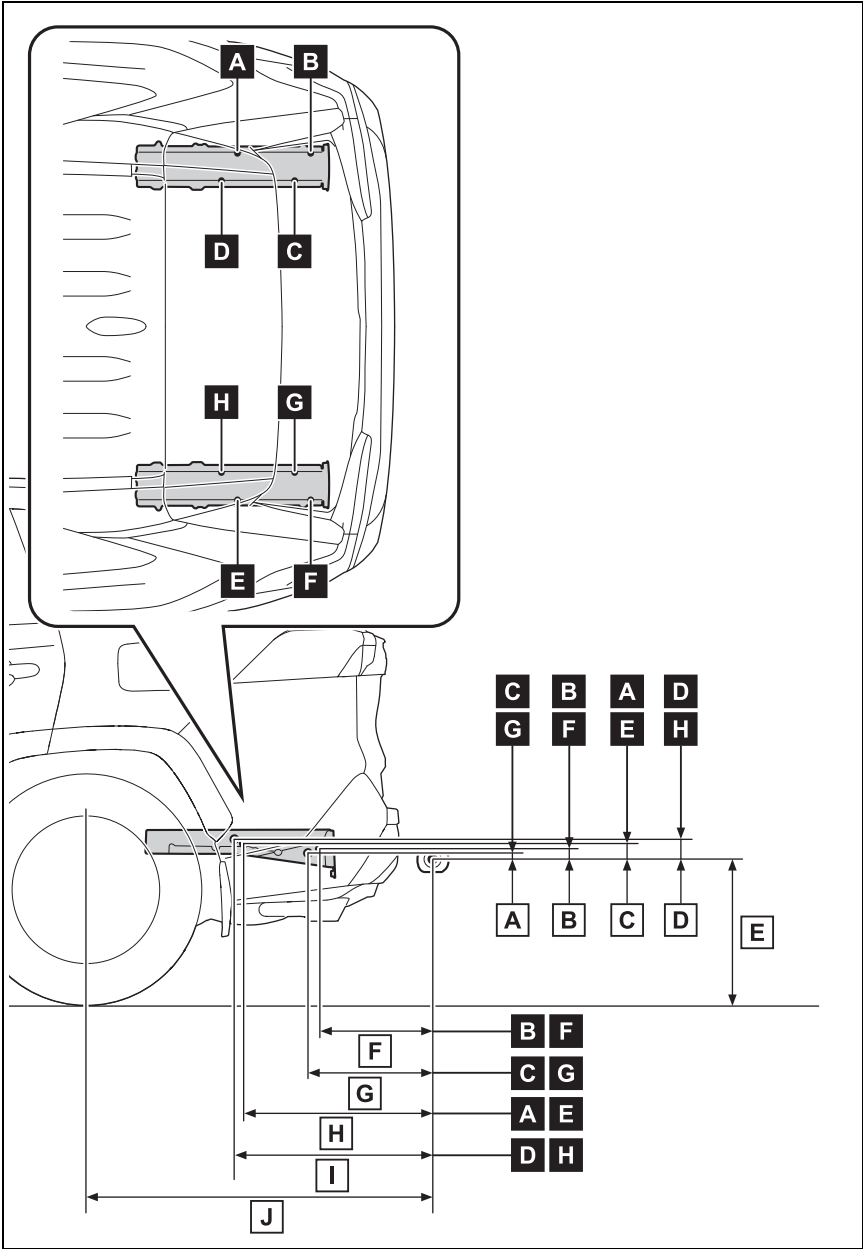

- A** 2 mm (0.07 in.)
- B** 13 mm (0.5 in.)
- C** 28 mm (1.1 in.)

- D** 34 mm (1.3 in.)
- E** 412 mm (16.2 in.)
- F** 332 mm (13.1 in.)
- G** 370 mm (14.6 in.)
- H** 570 mm (22.4 in.)
- I** 601 mm (23.7 in.)
- J** 1073 mm (42.2 in.)

**NOTICE**

■ When the rear bumper strengthening material is aluminum

Ensure the steel bracket part does not come directly in contact with that area.

When steel and aluminum come into contact, there is a reaction similar to corrosion, which will weaken the section concerned and may result in damage. Apply a rust inhibitor to parts that will come in contact when attaching a steel bracket.

Guidance

Your vehicle will handle differently when towing a trailer. In order to avoid accident, death or serious injury, keep the following in mind when towing:

■ Checking connections between trailer and lights

Stop the vehicle and check the operation of the connection between the trailer and lights after driving for a brief period as well as before starting off.

■ Practicing driving with a coupled trailer

- Get the feel for turning, stopping and reversing with the trailer coupled by practicing in an area with no or light traffic.
- When reversing with a coupled trailer, hold the section of the steering wheel nearest to you and rotate clockwise to turn the trailer left or counterclockwise to turn it right. Always rotate a little at a time to prevent steering error. Have someone guide you when reversing to lessen the risk of an accident.

■ Increasing vehicle-to-vehicle distance

At a speed of 10 km/h (6 mph), the distance to the vehicle running ahead of you should be equivalent to or greater than the combined length of your vehicle and trailer. Avoid sudden braking that may cause skidding. Otherwise, the vehicle may spin out of control. This is especially true when driving on wet or slippery road surfaces.

■ Sudden acceleration/steering input/cornering

Executing sharp turns when towing may result in the trailer colliding with your vehicle. Decelerate well in advance when approaching turns and take them slowly and carefully to avoid sudden braking.

■ Important points regarding turning

The wheels of the trailer will travel closer to the inside of the curve than the wheels of the vehicle. To make allowance for this, take the turns wider than you would normally do.

■ Important points regarding stability

Vehicle movement resulting from uneven road surfaces and strong crosswinds will affect handling. The vehicle may also be rocked by passing buses or large trucks. Frequently check behind when moving alongside such vehicles. As soon as such vehicle movement occurs, immediately start to decelerate smoothly by slowly applying the brakes. Always steer the vehicle straight ahead while braking.

■ Passing other vehicles

Consider the total combined length of your vehicle and trailer and ensure that the vehicle-to-vehicle distance is sufficient before executing lane changes.

■ Transmission information

To maintain engine braking efficiency, when using engine braking, do not use the transmission in D. (→P.283)

■ If the hybrid system overheats

Towing a loaded trailer up a long, steep incline in temperatures exceeding 30°C (85°F) may result in the hybrid system overheating. If the high coolant temperature warning light indicates that the hybrid system is overheating, turn the air conditioning off immediately, leave the road and stop the vehicle in a safe place. (→P.540)

■ When parking the vehicle

Always place wheel chocks under the wheels of both the vehicle and trailer. Firmly set the parking brake and shift the shift lever to P.

■ Break-in schedule

Suzuki recommends that vehicles fitted with new power train components should not be used for towing trailers for the first 800 km (500 miles).

■ Maintenance

- Maintenance must be performed more frequently when using the vehicle for towing due to the greater weight burden placed on the vehicle compared to normal driving.
- Retighten all bolts securing the hitching ball and bracket after towing for approximately 1000 km (600 miles).

■ If trailer sway occurs

One or more factors (crosswinds, passing vehicles, rough roads, etc.) can adversely affect handling of your vehicle and trailer, causing instability.

- If trailer swaying occurs:
 - Firmly grip the steering wheel. Steer straight ahead.
Do not try to control trailer swaying by turning the steering wheel.
 - Begin releasing the accelerator pedal immediately but very gradually to reduce speed.
Do not increase speed. Do not apply vehicle brakes.

If you make no extreme correction with the steering or brakes, your vehicle and trailer should stabilize (if enabled, Trailer Sway Control can also help to stabilize the vehicle and trailer.).

- After the trailer swaying has stopped:
 - Stop in a safe place. Get all occupants out of the vehicle.
 - Check the tires of the vehicle and the trailer.
 - Check the load in the trailer.
Make sure the load has not shifted.
Make sure the tongue weight is appropriate, if possible.
 - Check the load in the vehicle.
Make sure the vehicle is not overloaded after occupants get in.

If you cannot find any problems, the speed at which trailer swaying occurred is beyond the limit of your particular vehicle-trailer combination. Drive at a lower speed to prevent instability. Remember that swaying of the towing vehicle-trailer increases as speed increases.

Power (ignition) switch

Performing the following operations when carrying the electronic key on your person starts the hybrid system or changes power switch modes.

Starting the hybrid system

- 1 Check that the charging cable is disconnected. (→P.128)
 - 2 Pull the parking brake switch to check that the parking brake is set. (→P.288)
- The parking brake indicator will come on.
- 3 Check that the shift lever is set in P.
 - 4 Firmly depress the brake pedal.

 and a message will be displayed on the multi-information display. If it is not displayed, the hybrid system cannot be started.

- 5 Press the power switch shortly and firmly.

When operating the power switch, one short, firm press is enough. It is not necessary to press and hold the switch.

If the “READY” indicator turns on, the hybrid system will operate normally.

Continue depressing the brake pedal until the “READY” indicator is illuminated.

The hybrid system can be started from any power switch mode.

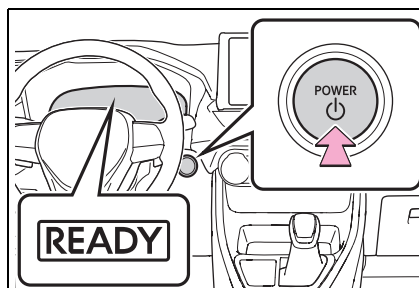

- 6 Check that the “READY” indicator is illuminated.

The vehicle will not move when the “READY” indicator is off.

Power switch illumination

According to the situation, the power switch illumination operates as follows.

- When driver’s door or front passenger’s door is opened, the power switch illumination illuminates.
- When depressing the brake pedal with carrying the electronic key on your person, the power switch illumination blinks.
- When the power switch is in ACC or ON, the power switch illumination illuminates.
- When the power switch mode is changed from ACC or ON to OFF, the power switch illumination illuminates for a certain amount of time. Afterwards, the power switch illumination turns off.

If the hybrid system does not start

- The immobilizer system may not have been deactivated. (→P.71)
Contact a SUZUKI dealer or a qualified workshop.
- If a message related to start-up is shown on the multi-information display, read the message and follow the instructions.

■ **When the ambient temperature is low, such as during winter driving conditions**

- When starting the hybrid system, the flashing time of the “READY” indicator may be long. Leave the vehicle as it is until the “READY” indicator is steady on, as steady means the vehicle is able to move.
- When the hybrid battery (traction battery) is extremely cold (below approximately -30°C [-22°F]) under the influence of the outside temperature, it may not be possible to start the hybrid system. In this case, try to start the hybrid system again after the temperature of the hybrid battery increases due to the outside temperature increase etc.

■ **Sounds and vibrations specific to a hybrid vehicle**

→P.85

■ **If the 12-volt battery is discharged**

The hybrid system cannot be started using the smart entry & start system. Refer to P.535 to restart the hybrid system.

■ **Electronic key battery depletion**

→P.188

■ **Conditions affecting operation**

→P.208

■ **Note for the entry function**

→P.208

■ **Steering lock function**

- After turning the power switch to OFF and opening and closing the doors, the steering wheel will be locked due to the steering lock function. Operating the power switch again automatically cancels the steering lock.
- When the steering lock cannot be released, “Push Power Switch while Turning Steering Wheel in Either Direction” will be displayed on the multi-information display. Check that the shift lever is set in P. Press the power switch shortly and

firmly while turning the steering wheel left and right.

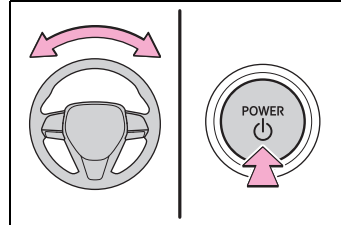

- To prevent the steering lock motor from overheating, the motor may be suspended if the hybrid system is turned on and off repeatedly in a short period of time. In this case, refrain from operating the power switch. After about 10 seconds, the steering lock motor will resume functioning.

■ **If there is a malfunction in the smart entry & start system**

If “Smart Entry & Start System Malfunction” is displayed on the multi-information display, the system may be malfunctioning. Have the vehicle inspected by a SUZUKI dealer or a qualified workshop immediately.

■ **If the “READY” indicator does not come on**

In the event that the “READY” indicator does not come on even after performing the proper procedures for starting the vehicle, contact a SUZUKI dealer or a qualified workshop immediately.

■ **If the hybrid system is malfunctioning**

→P.92

■ **Electronic key battery**

→P.484

■ **Operation of the power switch**

- If the switch is not pressed shortly and firmly, the power switch mode may not change or the hybrid system may not start.
- If attempting to restart the hybrid system immediately after turning the power switch to OFF, the hybrid system may not start in some cases. After

turning the power switch to OFF, please wait a few seconds before restarting the hybrid system.

■ Customization

If the smart entry & start system has been deactivated in a customized setting, refer to P.534.



WARNING

■ When starting the hybrid system

Always start the hybrid system while sitting in the driver's seat. Do not depress the accelerator pedal while starting the hybrid system under any circumstances.

Doing so may cause an accident resulting in death or serious injury.

■ Caution while driving

If hybrid system failure occurs while the vehicle is moving, do not lock or open the doors until the vehicle reaches a safe and complete stop. Activation of the steering lock in this circumstance may lead to an accident, resulting in death or serious injury.



NOTICE

■ When starting the hybrid system

If the hybrid system becomes difficult to start, have your vehicle checked by a SUZUKI dealer or a qualified workshop immediately.

■ Symptoms indicating a malfunction with the power switch

If the power switch seems to be operating somewhat differently than usual, such as the switch sticking slightly, there may be a malfunction. Contact a SUZUKI dealer or a qualified workshop immediately.

Stopping the hybrid system

- 1 Stop the vehicle completely.

- 2 If the parking brake is in manual mode, set the parking brake. (→P.288)

Check the parking brake indicator is illuminated.

- 3 Shift the shift lever to P.
- 4 Press the power switch shortly and firmly.

The hybrid system will stop, and the meter display will be extinguished. Release the shift lever when pressing the power switch.

- 5 Release the brake pedal and check that "ACCESSORY" or "IGNITION ON" is not shown on the multi-information display.



WARNING

■ Stopping the hybrid system in an emergency

- If you want to stop the hybrid system in an emergency while driving the vehicle, press and hold the power switch for more than 2 seconds, or press it briefly 3 times or more in succession. (→P.500) However, do not touch the power switch while driving except in an emergency. Turning the hybrid system off while driving will not cause a loss of steering or braking control. However, power assist for the steering wheel may be lost making it difficult to steer smoothly before stopping the vehicle depending on the remaining charge in the 12-volt battery or usage conditions. In this situation, you should pull over and stop the vehicle as soon as it is safe to do so.
- If the power switch is operated while the vehicle is running, a warning message will be shown on the multi-information display and a buzzer sounds.

! WARNING

- When restarting the hybrid system after an emergency shutdown, shift the shift lever to N and press the power switch shortly and firmly.

Changing power switch modes

Modes can be changed by pressing the power switch with the brake pedal released. (The mode changes each time the switch is pressed.)

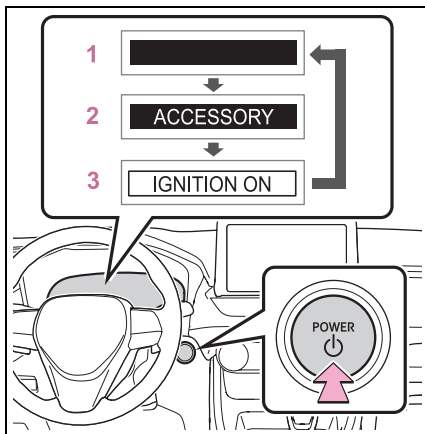

1 OFF*

The emergency flashers can be used.

2 ACC

Some electrical components such as the audio system can be used.

“ACCESSORY” will be displayed on the multi-information display.

3 ON

All electrical components can be used.

“IGNITION ON” will be displayed on the multi-information display.

*: If the shift lever is in a position other

than P when turning off the hybrid system, the power switch will remain ON, will not turn to OFF.

Auto power off function

- If the vehicle is left in ACC or ON (the hybrid system is not operating) for more than 20 minutes with the shift lever in P, the power switch will automatically turn to OFF.
- If the 12-volt battery is low with the shift lever is in P and the power switch is in ACC or ON (the hybrid system is not operating), a buzzer sounds and a message will be displayed on the multi-information display. If this continues, the power switch is automatically turn to OFF.

However, this function cannot entirely prevent the 12-volt battery discharge. Do not leave the vehicle with the power switch in ACC or ON for long periods of time when the hybrid system is not operating.

! NOTICE

To prevent 12-volt battery discharge

- Do not leave the power switch in ACC or ON for long periods of time without the hybrid system on.
- If “ACCESSORY” or “IGNITION ON” is displayed on the multi-information display, the power switch is not in OFF. Exit the vehicle after turning the power switch to OFF.

When stopping the hybrid system with the shift lever in a position other than P

If the hybrid system is stopped with the shift lever in a position other than P, the power switch will not be turned to OFF but instead be turned

to ACC. Perform the following procedure to turn the switch to OFF:

- 1 Check that the parking brake is set.
- 2 Shift the shift lever to P.
- 3 Check that "IGNITION ON" is displayed on the multi-information display and press the power switch shortly and firmly.
- 4 Check that "ACCESSORY" or "IGNITION ON" on the multi-information display is off.

 **NOTICE**

■ To prevent 12-volt battery discharge

Do not stop the hybrid system when the shift lever is in a position other than P. If the hybrid system is stopped in another shift lever position, the power switch will not be turned to OFF but instead remain ON. If the vehicle is left in ON, 12-volt battery discharge may occur.

Hybrid transmission

Select the shift position depending on your purpose and situation.

Shift position purpose and functions

Shift position	Objective or function
P	Parking the vehicle/starting the hybrid system
R	Reversing
N	Neutral
D	Normal driving*1, 2
S	S mode driving*3

*1: To improve fuel efficiency and reduce noise, shift the shift lever to D for normal driving.

*2: Selecting shift ranges in the D position allows suitable use of engine braking. (→P.285)

*3: By selecting shift ranges using S mode, you can control accelerating force and engine braking force.

■ When driving with dynamic radar cruise control with full-speed range

Even when performing the following actions with the intent of enabling engine braking, engine braking will not activate because dynamic radar cruise control with full-speed range will not be canceled.

- While driving in D or S mode, downshifting to 5 or 4. (→P.285, 286)
- When switching the driving mode to sport mode while driving in D position. (→P.388)

■ Restraining sudden start (Drive-Start Control)

→P.263

⚠ WARNING

■ **When driving on slippery road surfaces**

Be careful of downshifting and sudden acceleration, as this could result in the vehicle skidding to the side or spinning.

⚠ NOTICE

■ **Hybrid battery (traction battery) charge**

If the shift lever is in N, the hybrid battery (traction battery) will not be charging, even when the engine is running. Therefore, if the vehicle is left with the shift lever in N for a long period of time, the hybrid battery (traction battery) will discharge, and this may result in the vehicle not being able to start.

Shifting the shift lever

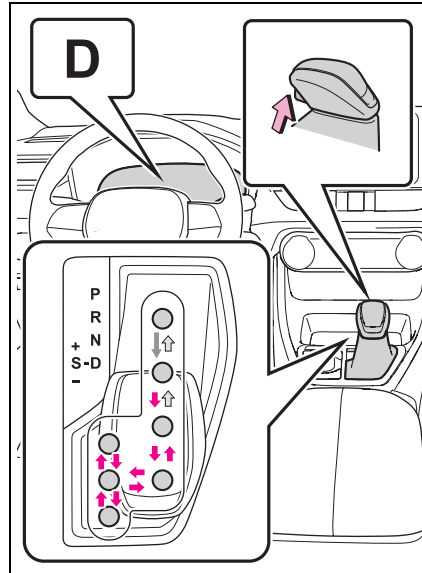

← While the power switch is in ON and the brake pedal depressed*, shift the shift lever while pushing the shift release button on the shift knob.

← Shift the shift lever while pushing the shift release button on the shift knob.

← Shift the shift lever normally.

When shifting the shift lever between P and D, make sure that the vehicle is completely stopped and the brake pedal is depressed.

*: For the vehicle to be able to be

shifted from P, the brake pedal must be depressed before the shift release button is pushed. If the shift release button is pushed first, the shift lock will not be released.

■ **Shift lock system**

The shift lock system is a system to prevent accidental operation of the shift lever in starting.

The shift lever can be shifted from P only when the power switch is in ON, the brake pedal is depressed and the shift release button is pushed.

■ **If the shift lever cannot be shifted from P**

First, check whether the brake pedal is being depressed. If the shift lever cannot be shifted even though the brake pedal is depressed and the shift release button is pushed, there may be a problem with the shift lock system. Have the vehicle inspected by a SUZUKI dealer or a qualified workshop immediately.

The following steps may be used as an emergency measure to ensure that the shift lever can be shifted.

Releasing the shift lock:

- 1 Pull the parking brake switch to check that the parking brake is set. (→P.288)
- 2 Turn the power switch off.
- 3 Depress the brake pedal.
- 4 Pry the cover up with a flathead screwdriver or equivalent tool. To prevent damage to the cover, cover the tip of the screwdriver with a rag.

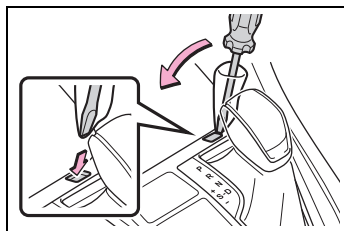

- 5 Press and hold the shift lock override button and then push the button on the shift knob. The shift lever can be shifted while both buttons are pressed.

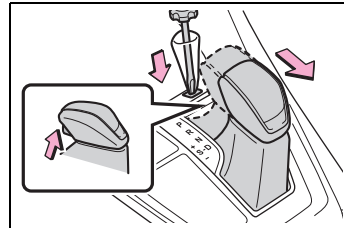

WARNING

■ **To prevent an accident when releasing the shift lock**

Before pressing the shift lock override button, make sure to set the parking brake and depress the brake pedal.

If the accelerator pedal is accidentally depressed instead of the brake pedal when the shift lock override button is pressed and the shift lever is shifted out of P, the vehicle may suddenly start, possibly leading to an accident resulting in death or serious injury.

Selecting the driving mode

→P.388

Selecting shift ranges in the D position

To drive using temporary shift range selection, operate the “-” paddle shift switch. The shift range can then be selected by operating the “-” and “+” paddle shift switches. Changing the shift range allows restriction of the highest gear, preventing upshifting and enabling the level of engine braking force to be

selected.

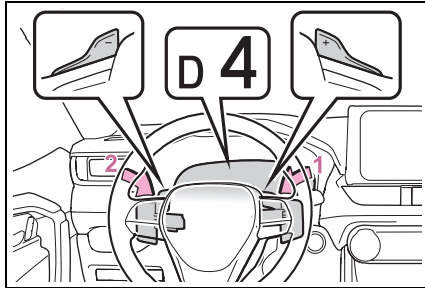

- 1 Upshifting
- 2 Downshifting

The selected shift range, from D1 to D6, will be displayed on the multi-information display.

■ **Shift ranges and their functions**

- You can choose from 6 levels of accelerating force and engine braking force.
- A lower shift range will provide greater accelerating force and engine braking force than a higher shift range, and the engine revolutions will also increase.

■ **Downshifting restriction warning buzzer**

To help ensure safety and driving performance, downshifting operation may sometimes be restricted. In some circumstances, downshifting may not be possible even when the paddle shift switch is operated. (A buzzer will sound twice.)

■ **Automatic deactivation of shift range selection in the D position**

Shift range selection in the D position will be deactivated in the following situations:

- When the vehicle comes to a stop
- If the accelerator pedal is depressed for more than a certain period of time
- When the shift lever is shifted to a position other than D

- When the “+” paddle shift switch is held down for a period of time

Changing shift ranges in S mode

When the shift lever is in the S position, the shift lever or paddle shift switches can be operated as follows:

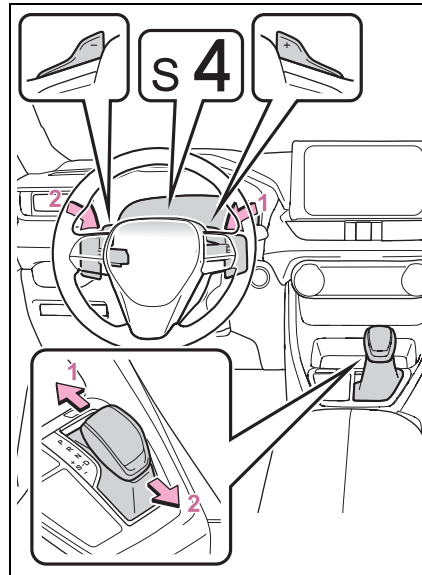

- 1 Upshifting
- 2 Downshifting

The selected shift range, from S1 to S6, will be displayed on the multi-information display.

The initial shift range in S mode is set automatically to S4.*

*: It is set to S3 when the driving mode is set to sport mode. (→P.388)

■ **S mode**

- You can choose from 6 levels of accelerating force and engine braking

force.

- A lower shift range will provide greater accelerating force and engine braking force than a higher shift range, and the engine revolutions will also increase.
- To prevent the engine from over-revving, upshifting may automatically occur when the shift range is 3 or lower.
- When the shift range is 4 or lower, holding the shift lever toward “+” sets the shift range to 6.

■ **Downshifting restriction warning buzzer**

To help ensure safety and driving performance, downshifting operation may sometimes be restricted. In some circumstances, downshifting may not be possible even when the shift lever or paddle shift switches is operated. (A buzzer will sound twice.)

■ **If the “S” indicator does not come on or the “D” indicator is displayed even after shifting the shift lever to S**

This may indicate a malfunction in the transmission system. Have the vehicle inspected by a SUZUKI dealer or a qualified workshop immediately. (In this situation, the transmission will operate in the same manner as when the shift lever is in D.)

Turn signal lever

Operating instructions

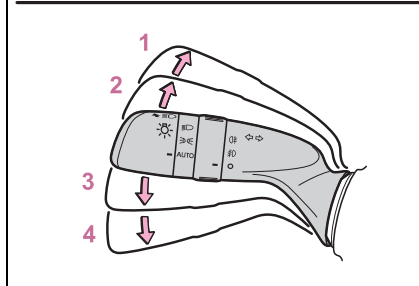
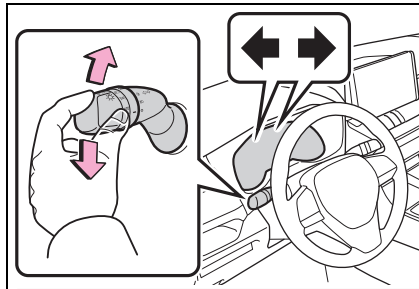

- 1 Right turn
- 2 Lane change to the right (move the lever partway and release it)
The right hand signals will flash 3 times.
- 3 Lane change to the left (move the lever partway and release it)
The left hand signals will flash 3 times.
- 4 Left turn

■ **Turn signals can be operated when**

The power switch is in ON.

■ **If the indicator flashes faster than usual**

Check that a light bulb in the front or rear turn signal lights has not burned out.

- **If the turn signals stop flashing before a lane change has been performed**

Operate the lever again.

- **To discontinue flashing of the turn signals during a lane change**

Operate the lever in the opposite direction.

Parking brake

The parking brake can be set or released automatically or manually. In automatic mode, the parking brake can be set or released automatically according to shift lever operation. Also, even in automatic mode, the parking brake can be set or released manually.

Operating instructions

- **Using the manual mode**

The parking brake can be set and released manually.

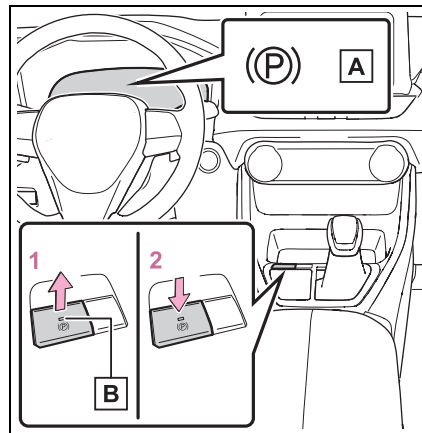

A Parking brake indicator light

B Parking brake switch indicator

- 1** Pull the switch to set the parking brake.

The parking brake indicator light and parking brake switch indicator will turn on.

Pull and hold the parking brake switch if

an emergency occurs and it is necessary to operate the parking brake while driving.

2 Push the switch to release the parking brake.

- Operate the parking brake switch while depressing the brake pedal.
- Parking brake automatic release function (→P.289)

Make sure that the parking brake indicator light and parking brake switch indicator turn off.

If the parking brake indicator light and parking brake switch indicator flash, operate the switch again. (→P.514)

■ Turning the automatic mode on

While the vehicle is stopped, pull and hold the parking brake switch until a buzzer sounds and a message is shown on the multi-information display.

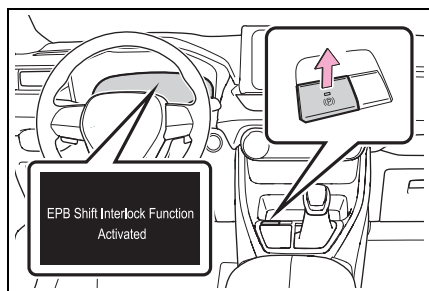

When the automatic mode is turned on, the parking brake operates as follows.

- When the shift lever is shifted from P, the parking brake will be released, and the parking brake indicator light and parking brake

switch indicator will turn off.

- When the shift lever is shifted to P, the parking brake will be set, and the parking brake indicator light and parking brake switch indicator will turn on.

Operate the shift lever with the vehicle stopped and the brake pedal depressed.

■ Turning the automatic mode off

While the vehicle is stopped and depressing the brake pedal, press and hold the parking brake switch until a buzzer sounds and a message is shown on the multi-information display.

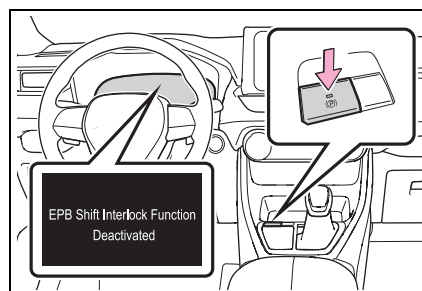

■ Parking brake operation

- When the power switch is not in ON, the parking brake cannot be released using the parking brake switch.
- When the power switch is not in ON, automatic mode (automatic brake setting and releasing) is not available.

■ Parking brake automatic release function

The parking brake will be released automatically when the accelerator pedal is slowly depressed under the following conditions:

- The driver's door is closed

- The driver is wearing the seat belt
- The shift lever is in a forward or reverse position.
- The malfunction indicator lamp or brake system warning light is not illuminated

If the automatic release function does not operate, release the parking brake manually.

■ **If “Parking Brake Temporarily Unavailable” is displayed on the multi-information display**

If the parking brake is operated repeatedly over a short period of time, the system may restrict operation to prevent overheating. If this happens, refrain from operating the parking brake. Normal operation will return after about 1 minute.

■ **If “Parking Brake Unavailable” is displayed on the multi-information display**

Operate the parking brake switch. If the message does not disappear after operating the switch several times, the system may be malfunctioning. Have the vehicle inspected by a SUZUKI dealer or a qualified workshop.

■ **Parking brake operation sound**

When the parking brake operates, a motor sound (whirring sound) may be heard. This does not indicate a malfunction.

■ **Parking brake indicator light**

- Depending on the power switch mode, the parking brake indicator light will turn on and stay on as described below:
ON: Comes on until the parking brake is released.
Not in ON: Stays on for approximately 15 seconds.
- When the power switch is turned off with the parking brake set, the parking brake indicator light will stay on for about 15 seconds. This does not indicate a malfunction.

■ **When the parking brake switch malfunctions**

Automatic mode (automatic brake setting and releasing) will be turned on automatically.

■ **Parking the vehicle**

→P.262

■ **Parking brake engaged warning buzzer**

A buzzer will sound if the vehicle is driven with the parking brake engaged. “Parking Brake ON” is displayed on the multi-information display (with the vehicle reaching a speed of 5 km/h [3 mph]).

■ **If the brake system warning light comes on**

→P.508

■ **Usage in winter time**

→P.400

	WARNING
<p>■ When parking the vehicle</p> <p>Do not leave a child in the vehicle alone. The parking brake may be released unintentionally by a child and there is the danger of the vehicle moving that may lead to an accident resulting in death or serious injury.</p>	
<p>■ Parking brake switch</p> <p>Do not set any objects near the parking brake switch. Objects may interfere with the switch and may lead the parking brake to unexpectedly operate.</p>	

	NOTICE
<p>■ When parking the vehicle</p> <p>Before you leave the vehicle, shift the shift lever to P, set the parking brake and make sure that the vehicle does not move.</p>	



NOTICE

■ **When the system malfunctions**

Stop the vehicle in a safe place and check the warning messages.

■ **When the parking brake cannot be released due to a malfunction**

Driving the vehicle with the parking brake set will lead to brake components overheating, which may affect braking performance and increase brake wear. Have the vehicle inspected by a SUZUKI dealer or a qualified workshop immediately if this occurs.

Brake Hold

The brake hold system keeps the brake applied when the shift lever is in D, S or N with the system on and the brake pedal has been depressed to stop the vehicle. The system releases the brake when the accelerator pedal is depressed with the shift lever in D or S to allow smooth start off.

Enabling the system

Press the brake hold switch to turn the brake hold system on

The brake hold standby indicator (green) **A** comes on. While the system is holding the brake, the brake hold operated indicator (yellow) **B** comes on.

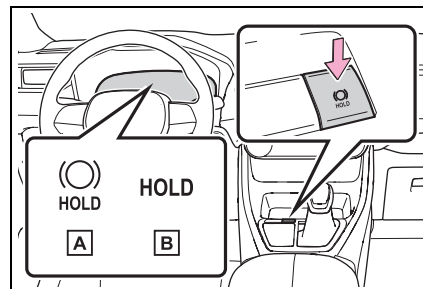

■ Brake hold system operating conditions

The brake hold system cannot be turned on in the following conditions:

- The driver's door is not closed.
- The driver is not wearing the seat belt.

If any of the conditions above are detected when the brake hold system is

enabled, the system will turn off and the brake hold standby indicator light will go off. In addition, if any of the conditions are detected while the system is holding the brake, a warning buzzer will sound and a message will be shown on the multi-information display. The parking brake will then be set automatically.

■ Brake hold function

- If the brake pedal is left released for a period of about 3 minutes after the system has started holding the brake, the parking brake will be set automatically. In this case, a warning buzzer sounds and a message is shown on the multi-information display.
- To turn the system off while the system is holding the brake, firmly depress the brake pedal and press the button again.
- The brake hold function may not hold the vehicle when the vehicle is on a steep incline. In this situation, it may be necessary for the driver to apply the brakes. A warning buzzer will sound and the multi-information display will inform the driver of this situation. If a warning message is shown on the multi-information display, read the message and follow the instructions.

■ When the parking brake is set automatically while the system is holding the brakes

Perform any of the following operations to release the parking brake:

- Depress the accelerator pedal. (The parking brake will not be released automatically if the seat belt is not fastened.)
- Operate the parking brake switch with the brake pedal depressed.

Make sure that the parking brake indicator light goes off. (→P.288)

■ When an inspection at a SUZUKI dealer or a qualified workshop is necessary

When the brake hold standby indicator

(green) does not illuminate even when the brake hold switch is pressed with the brake hold system operating conditions met, the system may be malfunctioning. Have the vehicle inspected at a SUZUKI dealer or a qualified workshop.

■ If “Brake Hold Malfunction Press Brake to Deactivate Visit Your Dealer” or “Brake Hold Malfunction Visit Your Dealer” is displayed on the multi-information display

The system may be malfunctioning. Have the vehicle inspected by a SUZUKI dealer or a qualified workshop.

■ Warning messages and buzzers

Warning messages and buzzers are used to indicate a system malfunction or to inform the driver of the need for caution. If a warning message is shown on the multi-information display, read the message and follow the instructions.

■ If the brake hold operated indicator flashes

→P.514



WARNING

■ When the vehicle is on a steep incline

When using the brake hold system on a steep incline, exercise caution. The brake hold function may not hold the vehicle in such a situation.

■ When stopped on a slippery road

The system cannot stop the vehicle when the gripping ability of the tires has been exceeded. Do not use the system when stopped on a slippery road.



NOTICE

■ When parking the vehicle

The brake hold system is not designed for use when parking the vehicle for a long period of time. Turning the power switch off while the system is holding the brake may release the brake, which would cause the vehicle to move. When operating the power switch, depress the brake pedal, shift the shift lever to P and set the parking brake.



Headlight switch

The headlights can be operated manually or automatically.

Turning on the headlights

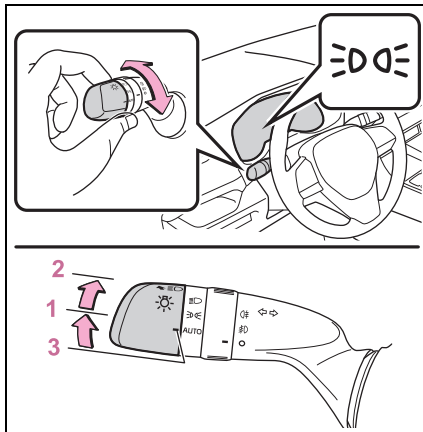
Operating the  switch turns on the lights as follows:



- 1  The front position, tail, license plate and instrument panel lights turn on.
- 2  The headlights and all lights listed above turn on.
- 3 AUTO The headlights, daytime running lights (→P.294) and all the lights listed above turn on and off automatically.

■ AUTO mode can be used when

The power switch is in ON.

■ Daytime running light system

To make your vehicle more visible to other drivers during daytime driving, the daytime running lights turn on automati-

cally whenever the hybrid system is started and the parking brake is released with the headlight switch in the



AUTO position. (Illuminate brighter than the front position lights.) Daytime running lights are not designed for use at night.

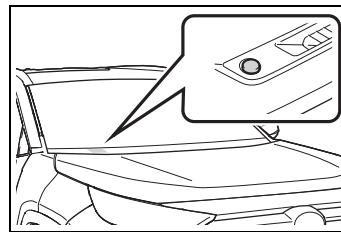

■ Headlight control sensor

The sensor may not function properly if an object is placed on the sensor, or anything that blocks the sensor is affixed to the windshield. Doing so interferes with the sensor detecting the level of ambient light and may cause the automatic headlight system to malfunction.



■ Automatic light off system

- When the light switch is in  or  position: The headlights and front fog lights turn off after the power switch is turned to ACC or OFF.
- When the light switch is in AUTO position: The headlights and all lights turn off after the power switch is turned to ACC or OFF.

To turn the lights on again, turn the power switch to ON, or turn the light switch to AUTO position once and then back to  or  position.

■ Light reminder buzzer

A buzzer sounds when the driver's door is opened while the lights are turned on with the power switch in ACC or OFF.

■ Automatic headlight leveling system

The level of the headlights is automati-

cally adjusted according to the number of passengers and the loading condition of the vehicle to ensure that the headlights do not interfere with other road users.

■ 12-volt battery-saving function

In order to prevent the 12-volt battery of the vehicle from discharging, if the light switch is in  position when the power switch is turned to OFF, the 12-volt battery-saving function will operate and automatically turn off all the lights after approximately 20 minutes.

When any of the following are performed, the 12-volt battery-saving function is canceled once and then reactivated. All the lights will turn off automatically 20 minutes after the 12-volt battery-saving function has been reactivated:

- When the headlight switch is operated
- When a door is opened or closed

■ If “Headlight System Malfunction Visit Your Dealer” is displayed on the multi-information display

The system may be malfunctioning. Have the vehicle inspected by a SUZUKI dealer or a qualified workshop.

■ Customization

Settings (e.g. light sensor sensitivity) can be changed.
(Customizable features: →P.561)



NOTICE

■ To prevent 12-volt battery discharge

Do not leave the lights on longer than necessary when the hybrid system is not operating.

Turning on the high beam headlights

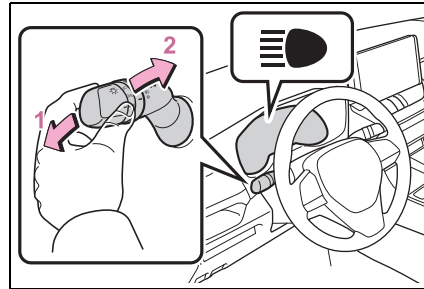

- 1 With the headlights on, push the lever away from you to turn on the high beams.

Pull the lever toward you to the center position to turn the high beams off.

- 2 Pull the lever toward you and release it to flash the high beams once.

You can flash the high beams with the headlights on or off.

Extended Headlight Lighting system

This system allows the headlights to be turned on for 30 seconds when the power switch is turned to OFF.

Pull the lever toward you and release it with the light switch is in **AUTO** after turning the power switch to OFF.

Pull the lever toward you and release it again to turn off the lights.

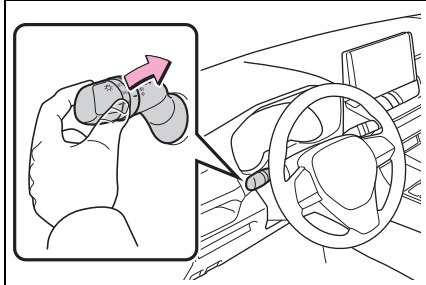

AHB (Automatic High Beam)

The Automatic High Beam uses an in-vehicle front camera to assess the brightness of streetlights, the lights of vehicles ahead etc., and automatically turns the high beams on or off as necessary.

WARNING

■ Limitations of the Automatic High Beam

Do not overly rely on the Automatic High Beam. Always drive safely, taking care to observe your surroundings and turning the high beams on or off manually if necessary.

■ To prevent incorrect operation of the Automatic High Beam system

Do not overload the vehicle.

Activating the Automatic High Beam system

- 1 Press the Automatic High Beam switch.

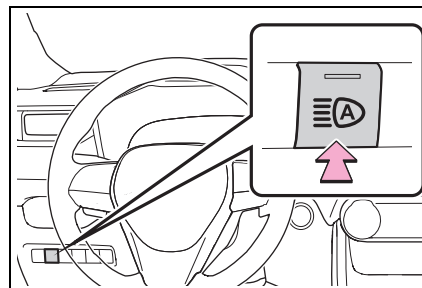

- 2 Turn the headlight switch to the AUTO or  position.

The Automatic High Beam indicator will

come on when the system is operating.

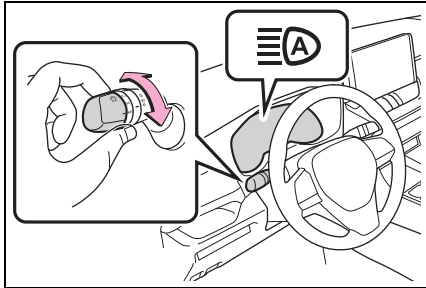

■ High beams automatic turning on or off conditions

- When all of the following conditions are fulfilled, the high beams will be automatically turned on (after approximately 1 second):
 - Vehicle speed is above approximately 30 km/h (19 mph) or more.
 - The area ahead of the vehicle is dark.
 - There are no vehicles ahead with headlights or tail lights turned on.
 - There are few streetlights on the road ahead.
- If any of the following conditions are fulfilled, the high beams will be automatically turned off:
 - Vehicle speed drops below approximately 25 km/h (16 mph).
 - The area ahead of the vehicle is not dark.
 - Vehicles ahead have headlights or tail lights turned on.
 - There are many streetlights on the road ahead.

■ Front camera detection information

- The high beams may not be automatically turned off in the following situations:
 - When oncoming vehicles suddenly appear from a curve
 - When the vehicle is cut in front of by another vehicle
 - When vehicles ahead are hidden from sight due to repeated curves, road dividers or roadside trees
 - When vehicles ahead appear from the faraway lane on a wide road

- When vehicles ahead have no lights
- The high beams may be turned off if a vehicle ahead that is using fog lights without using the headlights is detected.
- House lights, street lights, traffic signals, and illuminated billboards or signs may cause the high beams to switch to the low beams, or the low beams to remain on.
- The following factors may affect the amount of time taken to turn the high beams on or off:
 - The brightness of headlights, fog lights, and tail lights of vehicles ahead
 - The movement and direction of vehicles ahead
 - When a vehicle ahead only has operational lights on one side
 - When a vehicle ahead is a two-wheeled vehicle
 - The condition of the road (gradient, curve, condition of the road surface etc.)
 - The number of passengers and amount of luggage
- The high beams may be turned on or off when the driver does not expect it.
- Bicycles or similar objects may not be detected.
- In the situations shown below, the system may not be able to accurately detect surrounding brightness levels. This may cause the low beams to remain on or the high beams to cause problems for pedestrians, vehicles ahead or other parties. In these cases, manually switch between the high and low beams.
 - In bad weather (rain, snow, fog, sandstorms, etc.)
 - The windshield is obscured by fog, mist, ice, dirt, etc.
 - The windshield is cracked or damaged
 - The front camera is deformed or dirty
 - When the temperature of the front camera is extremely high
 - Surrounding brightness levels are equal to those of headlights, tail lights

- or fog lights
- When headlights or tail lights of vehicles ahead are turned off, dirty, changing color, or not aimed properly
- When the vehicle is hit by water, snow, dust, etc. from a preceding vehicle
- When driving through an area of intermittently changing brightness and darkness
- When frequently and repeatedly driving ascending/descending roads, or roads with rough, bumpy or uneven surfaces (such as stone-paved roads, gravel roads, etc.)
- When frequently and repeatedly taking curves or driving on a winding road
- There is a highly reflective object ahead of the vehicle, such as a sign or mirror
- The back of a vehicle ahead is highly reflective, such as a container on a truck
- The vehicle's headlights are damaged or dirty, or are not aimed properly
- The vehicle is listing or titling due to a flat tire, a trailer being towed, etc.
- The high beams and low beams are repeatedly being switched between in an abnormal manner
- The driver believes that the high beams may be causing problems or distress to other drivers or pedestrians nearby
- The vehicle is used in a territory in which vehicles travel on the opposite side of the road of the country for which the vehicle is approved, for example using a vehicle designed for right-hand traffic in a left-hand traffic territory, or vice versa
- When going through the Straits of Dover

■ **If “Headlight System Malfunction Visit Your Dealer” is displayed on the multi-information display**

The system may be malfunctioning. Have the vehicle inspected by a SUZUKI dealer or a qualified workshop.

Turning the high beams on/off manually

■ **Switching to the high beams**

Push the lever away from you.

The Automatic High Beam indicator will turn off and the headlight high beam indicator will turn on.

Pull the lever to its original position to activate the Automatic High Beam system again.

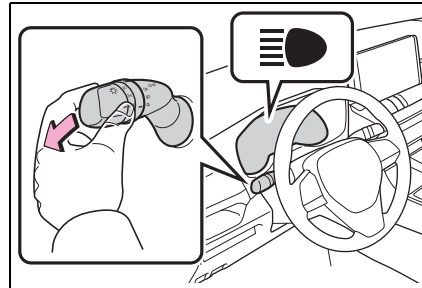

■ **Switching to the low beams**

Press the Automatic High Beam switch.

The Automatic High Beam indicator will turn off.

Press the switch to activate the Automatic High Beam system again.

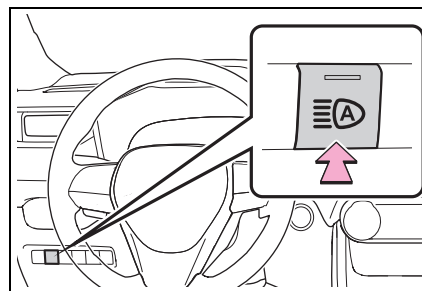

■ **Temporarily switching to the low beams**

Pull the lever toward you and then

return it to its original position.

The high beams are on while the lever is pulled toward you, however, after the lever is returned to its original position, the low beams remain on for a certain amount of time. Afterwards, the Automatic High Beam will be activated again.

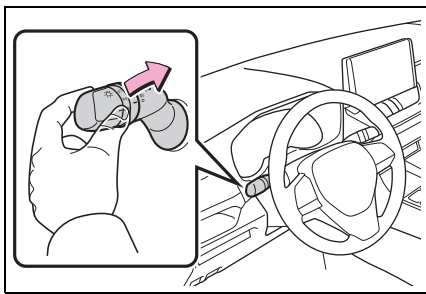

■ Temporarily switching to the low beams

It is recommended to switch to the low beams when the high beams may cause problems or distress to other drivers or pedestrians nearby.

Fog light switch

The fog lights offer improved visibility in difficult driving conditions, such as in rain and fog.

Operating procedure

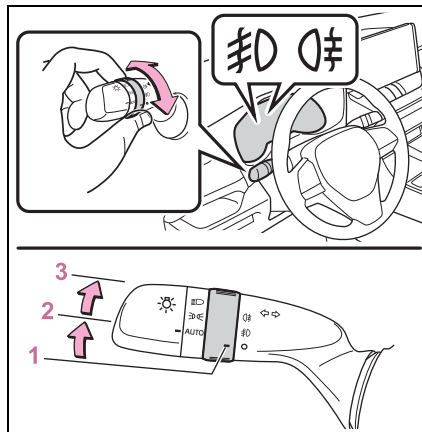

- 1 ○ Turns the front and rear fog lights off
- 2 ƒ Turns the front fog lights on
- 3 ƒ Turns both front and rear fog lights on

Releasing the switch ring returns it to ƒ .

Operating the switch ring again turns only the rear fog light off.

■ Fog lights can be used when

Front fog lights: The headlights or the front position lights are turned on.

Rear fog light: The front fog lights are turned on.

Windshield wipers and washer

Operating the lever can switch between automatic operation and manual operation, or can use the washer.

 NOTICE

■ **When the windshield is dry**
Do not use the wipers, as they may damage the windshield.

Operating the wiper lever

Operating the  lever operates the wipers or washer as follows:

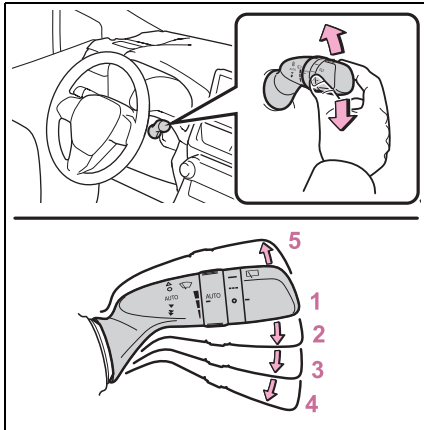

- 1 ○ Off
- 2 AUTO Rain-sensing operation
- 3 ▼ Low speed operation
- 4 ▼ High speed operation
- 5 △ Temporary operation

When "AUTO" is selected, the wipers will operate automatically when the

sensor detects falling rain. The system automatically adjusts wiper timing in accordance with rain volume and vehicle speed.

The sensor sensitivity can be adjusted when "AUTO" is selected.

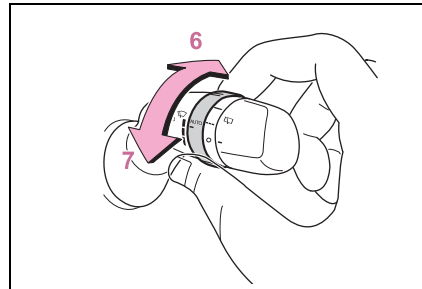

- 6 Increases the sensitivity
- 7 Decreases the sensitivity

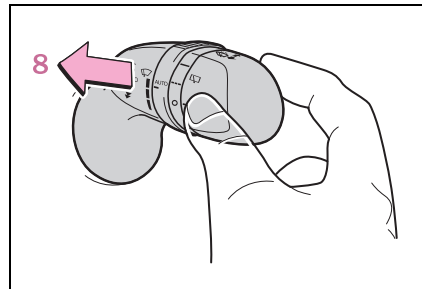

- 8  Washer/wiper dual operation

Pulling the lever operates the wipers and washer.

The wipers will automatically operate a couple of times after the washer squirts. When the power switch is in ON and the headlights are on, if the lever is pulled, the headlight cleaners will operate once. After this, the headlight cleaners will operate every 5th time the lever is pulled.

■ The windshield wipers and washer can be operated when

The power switch is in ON.

■ Effects of vehicle speed on wiper operation

With low speed windshield wiper operation selected, wiper operation will be switched from low speed to intermittent wiper operation when the vehicle is stationary. (However, when the sensor sensitivity is adjusted to the highest level, the mode will not switch.)

■ Raindrop sensor

- The raindrop sensor judges the amount of raindrops.* An optical sensor is adopted. It may not operate properly when sunlight from the rising or setting of the sun intermittently strikes the windshield, or if bugs, etc. are present on the windshield.

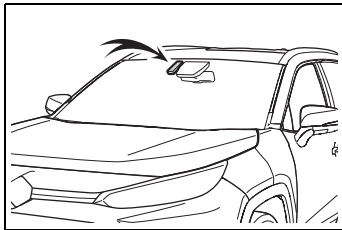

- If the wiper switch is turned to the "AUTO" position while the power switch is in ON, the wipers will operate once to show that "AUTO" mode is activated.
- If the wiper sensitivity is adjusted to higher, the wiper may operate once to indicate the change of sensitivity.
- If the temperature of the raindrop sensor is 85°C (185°F) or higher, or -15°C (5°F) or lower, the automatic operation may not occur. In this case, operate the wipers in any mode other than "AUTO".

*: It may be located on the opposite side depending on the target region.

■ If no windshield washer fluid sprays

Check that the washer nozzles are not blocked if there is washer fluid in the windshield washer fluid reservoir.

■ Washer nozzle heaters

The washer nozzle heaters operate to prevent frozen nozzle when the outside temperature is 5°C (41°F) or less and the power switch is in ON.

⚠ WARNING

■ Caution regarding the use of windshield wipers in "AUTO" mode

The windshield wipers may operate unexpectedly if the sensor is touched or the windshield is subject to vibration in "AUTO" mode. Take care that your fingers or anything else does not become caught in the windshield wipers.

■ Caution regarding the use of washer fluid

When it is cold, do not use the washer fluid until the windshield becomes warm. The fluid may freeze on the windshield and cause low visibility. This may lead to an accident, resulting in death or serious injury.

■ When the washer nozzle heaters are operating

Do not touch the area around the washer nozzle, as they can become very hot and burn you.

⚠ NOTICE

■ When the washer fluid tank is empty

Do not operate the switch continually as the washer fluid pump may overheat.



NOTICE

■ **When a nozzle becomes blocked**

In this case, contact a SUZUKI dealer or a qualified workshop. Do not try to clear it with a pin or other object. The nozzle will be damaged.

■ **To prevent 12-volt battery discharge**

Do not leave the wipers on longer than necessary when the hybrid system is off.

Rear window wiper and washer

The rear window wiper and washer can be used by operating the lever.



NOTICE

■ **When the rear window is dry**

Do not use the wiper, as it may damage the rear window.

Operating the wiper lever

Operating the  switch operates the rear wiper as follows:

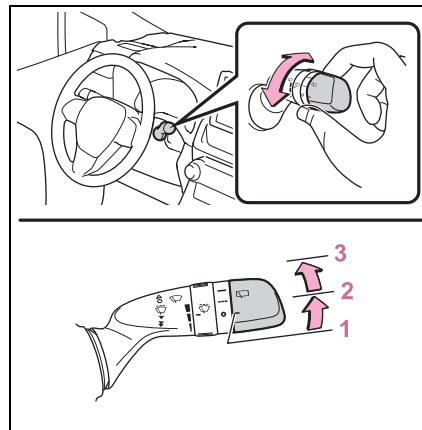

- 1 ○ Off
- 2 --- Intermittent operation
- 3 — Normal operation

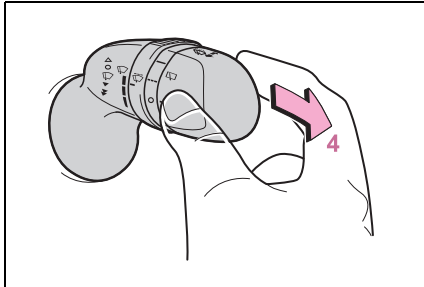

4 Washer/wiper dual operation

Pushing the lever operates the wiper and washer.

The wiper will automatically operate a couple of times after the washer squirts.

■ The rear window wiper and washer can be operated when

The power switch is in ON.

■ If no washer fluid sprays

Check that the washer nozzle is not blocked if there is washer fluid in the washer fluid reservoir.

■ Back door opening linked rear window wiper stop function

When the rear window wiper is operating, if the back door is opened while the vehicle is stopped, operation of the rear window wiper will be stopped to prevent anyone near the vehicle from being sprayed by water from the wiper. When the back door is closed, wiper operation will resume.*

*: The setting must be customized at a SUZUKI dealer or a qualified workshop.

■ Reverse-linked rear window wiper function

When the shift lever is shifted to R when the front wipers are operating, the rear window wiper will operate once.

■ Customization

Setting of the reverse-linked function

can be changed.

(Customizable features: →P.562)

NOTICE

■ When the washer fluid tank is empty

Do not operate the switch continually as the washer fluid pump may over-heat.

■ When a nozzle becomes blocked

In this case, contact a SUZUKI dealer or a qualified workshop.

Do not try to clear it with a pin or other object. The nozzle will be damaged.

■ To prevent 12-volt battery discharge

Do not leave the wiper on longer than necessary when the hybrid system is off.

Opening the fuel tank cap

Perform the following steps to open the fuel tank cap:

Before refueling the vehicle

- Close all the doors and windows, and turn the power switch to OFF.
- Confirm the type of fuel.

Fuel types

→P.554

Fuel tank opening for unleaded gasoline

To help prevent incorrect fueling, your vehicle has a fuel tank opening that only accommodates the special nozzle on unleaded fuel pumps.

WARNING

When refueling the vehicle

Observe the following precautions while refueling the vehicle. Failure to do so may result in death or serious injury.

- After exiting the vehicle and before opening the fuel door, touch an unpainted metal surface to discharge any static electricity. It is important to discharge static electricity before refueling because sparks resulting from static electricity can cause fuel vapors to ignite while refueling.

- Always hold the grips on the fuel tank cap and turn it slowly to remove it. A whooshing sound may be heard when the fuel tank cap is loosened. Wait until the sound cannot be heard before fully removing the cap. In hot weather, pressurized fuel may spray out of the filler neck and cause injury.

- Do not allow anyone that has not discharged static electricity from their body to come close to an open fuel tank.

- Do not inhale vaporized fuel. Fuel contains substances that are harmful if inhaled.

- Do not smoke while refueling the vehicle. Doing so may cause the fuel to ignite and cause a fire.

- Do not return to the vehicle or touch any person or object that is statically charged. This may cause static electricity to build up, resulting in a possible ignition hazard.

When refueling

Observe the following precautions to prevent fuel overflowing from the fuel tank:

- Securely insert the fuel nozzle into the fuel filler neck.
- Stop filling the tank after the fuel nozzle automatically clicks off.
- Do not top off the fuel tank.

NOTICE

Refueling

Do not spill fuel during refueling. Doing so may damage the vehicle, such as causing the emission control system to operate abnormally or damaging fuel system components or the vehicle's painted surface.

 **NOTICE**
 ■ **Notice about fuel**
 →P.91

Opening the fuel tank cap

- 1 Press the opener to open the fuel filler door.

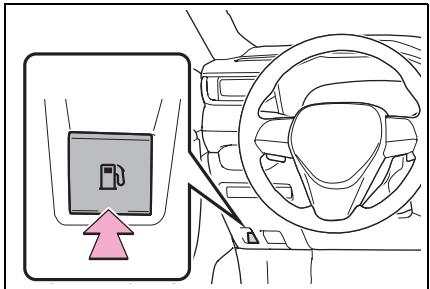
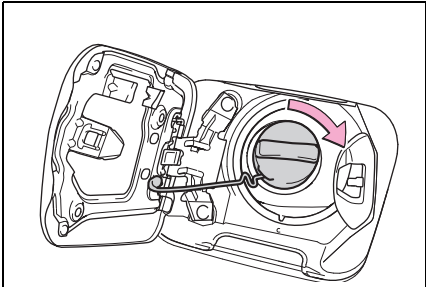

- 2 Turn the fuel tank cap slowly to open it and put it into the holder on the fuel filler door.

 **WARNING**
 ■ **When replacing the fuel tank cap**
 Do not use anything but a genuine Suzuki fuel tank cap designed for your vehicle. Doing so may cause a fire or other incident which may result in death or serious injury.

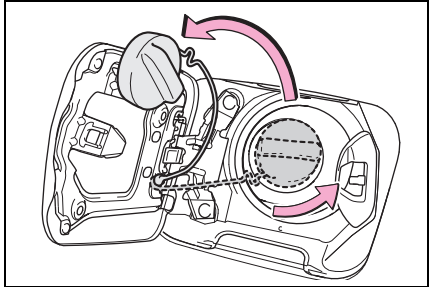

■ **If the fuel filler door cannot be opened**
 →P.532

Closing the fuel tank cap

After refueling, turn the fuel tank cap until you hear a click. Once the cap is released, it will turn slightly in the opposite direction.

Safety Sense

The Safety Sense consists of the following drive assist systems and contributes to a safe and comfortable driving experience:

Driving assist system

- **PCS (Pre-Collision System)**
→P.316
- **LTA (Lane Tracing Assist)**
→P.323
- **AHB (Automatic High Beam)**
→P.296
- **RSA (Road Sign Assist)**
→P.333
- **Dynamic radar cruise control with full-speed range**
→P.337

WARNING

■ **Safety Sense**

The Safety Sense is designed to operate under the assumption that the driver will drive safely, and is designed to help reduce the impact to the occupants and the vehicle in the case of a collision or assist the driver in normal driving conditions. As there is a limit to the degree of recognition accuracy and control performance that this system can provide, do not overly rely on this system. The driver is always responsible for paying attention to the vehicle's surroundings and driving safely.

Sensors

Two types of sensors, located behind the front grille and windshield, detect information necessary to operate the drive assist systems.

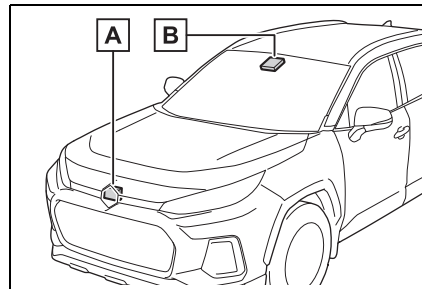

A Radar sensor

B Front camera

WARNING

■ **To avoid malfunction of the radar sensor**

Observe the following precautions. Otherwise, the radar sensor may not operate properly, possibly leading to an accident resulting in death or serious injury.

⚠ WARNING

- Keep the radar sensor and the radar sensor cover clean at all times.

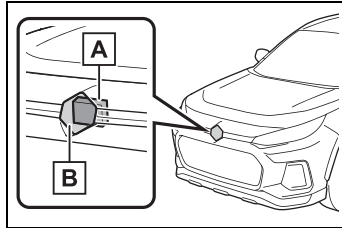

A Radar sensor

B Radar sensor cover

If the front of the radar sensor or the front or back of the radar sensor cover is dirty or covered with water droplets, snow, etc., clean it.

Clean the radar sensor and radar sensor cover with a soft cloth to avoid damaging them.

- Do not attach accessories, stickers (including transparent stickers) or other items to the radar sensor, radar sensor cover or surrounding area.
- Do not subject the radar sensor or its surrounding area to a strong impact.
If the radar sensor, front grille, or front bumper has been subjected to a strong impact, have the vehicle inspected by a SUZUKI dealer or a qualified workshop.
- Do not disassemble the radar sensor.
- Do not modify or paint the radar sensor or radar sensor cover.
- In the following cases, the radar sensor must be recalibrated. Contact a SUZUKI dealer or a qualified workshop for details.

- When the radar sensor or front grille are removed and installed, or replaced
- When the front bumper is replaced

■ To avoid malfunction of the front camera

Observe the following precautions. Otherwise, the front camera may not operate properly, possibly leading to an accident resulting in death or serious injury.

- Keep the windshield clean at all times.
- If the windshield is dirty or covered with an oily film, water droplets, snow, etc., clean the windshield.
- If a glass coating agent is applied to the windshield, it will still be necessary to use the windshield wipers to remove water droplets, etc. from the area of the windshield in front of the front camera.
- If the inner side of the windshield where the front camera is installed is dirty, contact a SUZUKI dealer or a qualified workshop.

⚠ WARNING

- Do not attach objects, such as stickers, transparent stickers, etc., to the outer side of the windshield in front of the front camera (shaded area in the illustration).

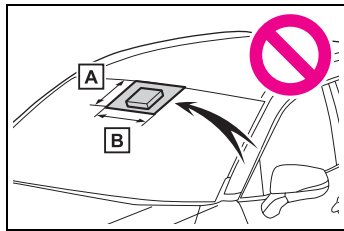

A From the top of the windshield to approximately 1 cm (0.4 in.) below the bottom of the front camera

B Approximately 20 cm (7.9 in.) (Approximately 10 cm [4.0 in.] to the right and left from the center of the front camera)

- If the part of the windshield in front of the front camera is fogged up or covered with condensation, or ice, use the windshield defogger to remove the fog, condensation, or ice. (→P.407)
- If water droplets cannot be properly removed from the area of the windshield in front of the front camera by the windshield wipers, replace the wiper insert or wiper blade.
- Do not attach window tint to the windshield.
- Replace the windshield if it is damaged or cracked. After replacing the windshield, the front camera must be recalibrated. Contact a SUZUKI dealer or a qualified workshop for details.
- Do not allow liquids to contact the front camera.

- Do not allow bright lights to shine into the front camera.
- Do not dirty or damage the front camera. When cleaning the inside of the windshield, do not allow glass cleaner to contact the lens of the front camera. Also, do not touch the lens. If the lens is dirty or damaged, contact a SUZUKI dealer or a qualified workshop.
- Do not subject the front camera to a strong impact.
- Do not change the installation position or direction of the front camera or remove it.
- Do not disassemble the front camera.
- Do not modify any components of the vehicle around the front camera (inside rear view mirror, etc.) or ceiling.
- Do not attach any accessories to the hood, front grille or front bumper that may obstruct the front camera. Contact a SUZUKI dealer or a qualified workshop for details.
- If a surfboard or other long object is to be mounted on the roof, make sure that it will not obstruct the front camera.
- Do not modify the headlights or other lights.

■ Certification

Transmitter:	Model: DNMWR009 Operation frequency: 76.5 GHz Maximum output power: 416.87 mW or less
Manufacturer:	DENSO CORPORATION
Address:	1-1, Showa-cho, Kariya-shi, Aichi-ken, 448-8661 Japan
<p>Hereby, DENSO CORPORATION declares that the radio equipment type is in compliance with Directive 2014/53/EU. The full text of the EU declaration of conformity is available at the following internet address: https://www.denso.com/global/en/contact-us/doc/</p>	
01	
<p>DENSO CORPORATION vakuuttaa, että radiolaitetyyppi on direktiivin 2014/53/EU mukainen. EU-vaatimustenmukaisuusvakuutuksen täysimittainen teksti on saatavilla seuraavassa internetosoitteessa: https://www.denso.com/global/en/contact-us/doc/</p>	
02	
<p>Hierbij verklaar ik, DENSO CORPORATION, dat het type radioapparatuur conform is met Richtlijn 2014/53/EU. De volledige tekst van de EU-conformiteitsverklaring kan worden geraadpleegd op het volgende internetadres: https://www.denso.com/global/en/contact-us/doc/</p>	
03	
<p>Le soussigné, DENSO CORPORATION, déclare que l'équipement radioélectrique du type est conforme à la directive 2014/53/UE. Le texte complet de la déclaration UE de conformité est disponible à l'adresse internet suivante: https://www.denso.com/global/en/contact-us/doc/</p>	
04	

Härmed försäkrar DENSO CORPORATION att denna typ av radioutrustning överensstämmer med direktiv 2014/53/EU.
Den fullständiga texten till EU-försäkran om överensstämmelse finns på följande webbadress:
<https://www.denso.com/global/en/contact-us/doc/>

05

Hermed erklærer DENSO CORPORATION, at radioudstyrstypen er i overensstemmelse med direktiv 2014/53/EU.
EU-overensstemmelseserklæringens fulde tekst kan findes på følgende internetadresse:
<https://www.denso.com/global/en/contact-us/doc/>

06

Hiermit erklärt DENSO CORPORATION, dass der Funkanlagentyp der Richtlinie 2014/53/EU entspricht.
Der vollständige Text der EU-Konformitätserklärung ist unter der folgenden Internetadresse verfügbar:
<https://www.denso.com/global/en/contact-us/doc/>

07

Με την παρούσα ο/η DENSO CORPORATION, δηλώνει ότι ο ραδιοεξοπλισμός πληροί την οδηγία 2014/53/ΕΕ.
Το πλήρες κείμενο της δήλωσης συμμόρφωσης ΕΕ διατίθεται στην ακόλουθη ιστοσελίδα στο διαδίκτυο:
<https://www.denso.com/global/en/contact-us/doc/>

08

Il fabbricante, DENSO CORPORATION, dichiara che il tipo di apparecchiatura radio è conforme alla direttiva 2014/53/UE.
Il testo completo della dichiarazione di conformità UE è disponibile al seguente indirizzo Internet:
<https://www.denso.com/global/en/contact-us/doc/>

09

<p>Por la presente, DENSO CORPORATION declara que el tipo de equipo radioeléctrico es conforme con la Directiva 2014/53/UE. El texto completo de la declaración UE de conformidad está disponible en la dirección Internet siguiente: https://www.denso.com/global/en/contact-us/doc/</p>	10
<p>O(a) abaixo assinado(a) DENSO CORPORATION declara que o presente tipo de equipamento de rádio está em conformidade com a Diretiva 2014/53/UE. O texto integral da declaração de conformidade está disponível no seguinte endereço de Internet: https://www.denso.com/global/en/contact-us/doc/</p>	11
<p>B'dan, DENSO CORPORATION, niddikjara li dan it-tip ta' tagħmir tar-radju huwa konformi mad-Direttiva 2014/53/UE. It-test kollu tad-dikjarazzjoni ta' konformità tal-UE huwa disponibbli f'dan l-indirizz tal-Internet li ġej: https://www.denso.com/global/en/contact-us/doc/</p>	12
<p>Käesolevaga deklareerib DENSO CORPORATION, et käesolev raadioseadme tüüp vastab direktiivi 2014/53/EL nõuetele. ELi vastavusdeklaratsiooni täielik tekst on kättesaadav järgmisel internetiaadressil: https://www.denso.com/global/en/contact-us/doc/</p>	13
<p>DENSO CORPORATION igazolja, hogy a típusú rádióberendezés megfelel a 2014/53/EU irányelvnek. Az EU-megfelelőségi nyilatkozat teljes szövege elérhető a következő internetes címen: https://www.denso.com/global/en/contact-us/doc/</p>	14

DENSO CORPORATION týmto vyhlasuje, že rádiové zariadenie typu je v súlade so smernicou 2014/53/EÚ.

Úplné EÚ vyhlásenie o zhode je k dispozícii na tejto internetovej adrese:

<https://www.denso.com/global/en/contact-us/doc/>

15

Tímto DENSO CORPORATION prohlašuje, že typ rádiového zařízení je v souladu se směrnicí 2014/53/EU.

Úplné znění EU prohlášení o shodě je k dispozici na této internetové adrese:

<https://www.denso.com/global/en/contact-us/doc/>

16

DENSO CORPORATION potvrdjuje, da je tip radijske opreme skladen z Direktivo 2014/53/EU.

Celotno besedilo izjave EU o skladnosti je na voljo na naslednjem spletnem naslovu:

<https://www.denso.com/global/en/contact-us/doc/>

17

Aš, DENSO CORPORATION, patvirtinu, kad radijo įrenginių tipas atitinka Direktyvą 2014/53/ES.

Visas ES atitikties deklaracijos tekstas prieinamas šiuo interneto adresu:

<https://www.denso.com/global/en/contact-us/doc/>

18

Ar šo DENSO CORPORATION deklarē, ka radioiekārta atbilst Direktīvai 2014/53/ES.

Pilns ES atbilstības deklarācijas teksts ir pieejams šādā interneta vietnē:

<https://www.denso.com/global/en/contact-us/doc/>

19

DENSO CORPORATION niniejszym oświadcza, że typ urządzenia radiowego jest zgodny z dyrektywą 2014/53/UE.
Pełny tekst deklaracji zgodności UE jest dostępny pod następującym adresem internetowym:
<https://www.denso.com/global/en/contact-us/doc/>

20

Hér með lýsir DENSO CORPORATION yfir því að er í samræmi við grunnkröfur og aðrar kröfur, sem gerðar eru í tilskipun 2014/53/EU. Samræmisýfirlýsing er einnig aðgengileg á eftirfarandi vefslóð:
<https://www.denso.com/global/en/contact-us/doc/>

21

DENSO CORPORATION erklærer at er i overensstemmelse med direktiv 2014/53/EU.
Samsvarserklæringen i fulltekst er tilgjengelig på følgende internettsadresse:
<https://www.denso.com/global/en/contact-us/doc/>

22

С настоящото DENSO CORPORATION декларира, че този тип радиосъоръжение е в съответствие с Директива 2014/53/ЕС. Цялостният текст на ЕС декларацията за съответствие може да се намери на следния интернет адрес:
<https://www.denso.com/global/en/contact-us/doc/>

23

Prin prezenta, DENSO CORPORATION declară că tipul de echipamente radio este în conformitate cu Directiva 2014/53/UE. Textul integral al declarației UE de conformitate este disponibil la următoarea adresă internet:
<https://www.denso.com/global/en/contact-us/doc/>

24

DENSO CORPORATION ovime izjavljuje da je radijska oprema tipa u skladu s Direktivom 2014/53/EU.
Cjeloviti tekst EU izjave o sukladnosti dostupan je na sljedećoj internetskoj adresi:
<https://www.denso.com/global/en/contact-us/doc/>

25

Овиме, DENSO CORPORATION изјављује да је радио опрема тип усаглашена са Директивом 2014/53/EU.
Цео текст ЕУ декларације о усаглашености доступан је на следећој интернет адреси:
<https://www.denso.com/global/en/contact-us/doc/>

26

Amb aquest document, DENSO CORPORATION declara que el tipus d'equipament radioelèctric es conforme a la Directiva 2014/53/UE.
El text complet de la declaració UE de conformitat està disponible en la següent adreça d'Internet:
<https://www.denso.com/global/en/contact-us/doc/>

27

İşbu belge; DENSO CORPORATION telsiz ekipmanı tipinin 2014/53/AB sayılı Direktif'e uygun olduğunu beyan eder.
AB uygunluk beyanının tam metni aşağıdaki internet adresinde mevcuttur:
<https://www.denso.com/global/en/contact-us/doc/>

28

Nepermjet kesaj, DENSO CORPORATION, deklaroj qe ky DNMWR009 eshte ne pajtim me kerkesat thelbesore dhe dispozitat e tjera perkatese te Direktives 1999/5/EC.

29



The latest "DECLARATION of CONFORMITY" (DoC) is available at the following address:
<https://www.denso.com/global/en/contact-us/doc/>

■ **If a warning message is displayed on the multi-information display**

A system may be temporarily unavailable or there may be a malfunction in the system.

- In the following situations, perform the actions specified in the table. When the normal operating conditions are detected, the message will disappear and the system will become operational.

If the message does not disappear, contact a SUZUKI dealer or a qualified workshop.

Situation	Actions
When the area around a sensor is covered with dirt, moisture (fogged up, covered with condensation, ice, etc.), or other foreign matter	To clean the part of the windshield in front of the front camera, use the windshield wipers or the windshield defogger of the air conditioning system (→P.407).
When the temperature around the front camera is outside of the operational range, such as when the vehicle is in the sun or in an extremely cold environment	If the front camera is hot, such as after the vehicle had been parked in the sun, use the air conditioning system to decrease the temperature around the front camera. If a sunshade was used when the vehicle was parked, depending on its type, the sunlight reflected from the surface of the sunshade may cause the temperature of the front camera to become excessively high.
	If the front camera is cold, such as after the vehicle is parked in an extremely cold environment, use the air conditioning system to increase the temperature around the front camera.
The area in front of the front camera is obstructed, such as when the hood is open or a sticker is attached to the part of the windshield in front of the front camera.	Close the hood, remove the sticker, etc. to clear the obstruction.

- In the following situations, if the situation has changed (or the vehicle has been driven for some time) and the normal operating conditions are detected, the message will disappear and the system will become operational.

If the message does not disappear, contact a SUZUKI dealer or a qualified workshop.

- When the temperature around the radar sensor is outside of the operational range, such as when the vehicle is in the sun or in an extremely cold environment
- When the front camera cannot detect objects in front of the vehicle, such as when driving in the dark, snow, or fog, or when bright lights are shining into the front camera

PCS (Pre-Collision System)

The pre-collision system uses a radar sensor and front camera to detect objects (→P.316) in front of the vehicle. When the system determines that the possibility of a frontal collision with an object is high, a warning operates to urge the driver to take evasive action and the potential brake pressure is increased to help the driver avoid the collision. If the system determines that the possibility of a frontal collision with an object is extremely high, the brakes are automatically applied to help avoid the collision or help reduce the impact of the collision.

The pre-collision system can be disabled/enabled and the warning timing can be changed. (→P.318)

Detectable objects

The system can detect the following:

- Vehicles
- Bicyclists
- Pedestrians

System functions

■ Pre-collision warning

When the system determines that the possibility of a frontal collision is high, a buzzer will sound and a warning message will be displayed on the multi-information display to urge the driver to take evasive action.

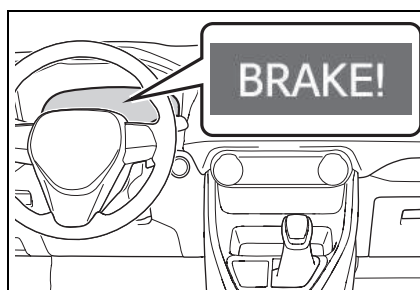

■ Pre-collision brake assist

When the system determines that the possibility of a frontal collision is high, the system applies greater braking force in relation to how strongly the brake pedal is depressed.

■ Pre-collision braking

If the system determines that the possibility of a frontal collision is extremely high, the brakes are automatically applied to help avoid the collision or reduce the impact of the collision.

**WARNING****■ Limitations of the pre-collision system**

- The driver is solely responsible for safe driving. Always drive safely, taking care to observe your surroundings.
Do not use the pre-collision system instead of normal braking operations under any circumstances. This system will not prevent collisions or lessen collision damage or injury in every situation. Do not overly rely on this system. Failure to do so may lead to an accident, resulting in death or serious injury.
- Although this system is designed to help avoid a collision or help reduce the impact of the collision, its effectiveness may change according to various conditions, therefore the system may not always be able to achieve the same level of performance.
Read the following conditions carefully. Do not overly rely on this system and always drive carefully.
- Conditions under which the system may operate even if there is no possibility of a collision: →P.320
- Conditions under which the system may not operate properly: →P.321
- Do not attempt to test the operation of the pre-collision system yourself. Depending on the objects used for testing (dummies, cardboard objects imitating detectable objects, etc.), the system may not operate properly, possibly leading to an accident.

■ Pre-collision braking

- When the pre-collision braking function is operating, a large amount of braking force will be applied.

- If the vehicle is stopped by the operation of the pre-collision braking function, the pre-collision braking function operation will be canceled after approximately 2 seconds. Depress the brake pedal as necessary.

- The pre-collision braking function may not operate if certain operations are performed by the driver. If the accelerator pedal is being depressed strongly or the steering wheel is being turned, the system may determine that the driver is taking evasive action and possibly prevent the pre-collision braking function from operating.

- In some situations, while the pre-collision braking function is operating, operation of the function may be canceled if the accelerator pedal is depressed strongly or the steering wheel is turned and the system determines that the driver is taking evasive action.

- If the brake pedal is being depressed, the system may determine that the driver is taking evasive action and possibly delay the operation timing of the pre-collision braking function.

■ When to disable the pre-collision system

In the following situations, disable the system, as it may not operate properly, possibly leading to an accident resulting in death or serious injury:

- When the vehicle is being towed
- When your vehicle is towing another vehicle
- When transporting the vehicle via truck, boat, train or similar means of transportation
- When the vehicle is raised on a lift with the hybrid system on and the tires are allowed to rotate freely

⚠ WARNING

- When inspecting the vehicle using a drum tester such as a chassis dynamometer or speedometer tester, or when using an on vehicle wheel balancer
- When a strong impact is applied to the front bumper or front grille, due to an accident or other reasons
- If the vehicle cannot be driven in a stable manner, such as when the vehicle has been in an accident or is malfunctioning
- When the vehicle is driven in a sporty manner or off-road
- When the tires are not properly inflated
- When the tires are very worn
- When tires of a size other than specified are installed
- When tire chains are installed
- When a compact spare tire or an emergency tire puncture repair kit is used
- If equipment (snow plow, etc.) that may obstruct the radar sensor or front camera is temporarily installed to the vehicle

Changing settings of the pre-collision system

■ **Enabling/disabling the pre-collision system**

The pre-collision system can be enabled/disabled on the  screen (→P.177) of the multi-information display.

The system is automatically enabled each time the power switch is turned to

ON.

If the system is disabled, the PCS warning light will turn on and a message will be displayed on the multi-information display.

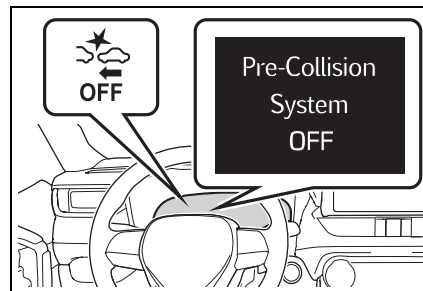

■ **Changing the pre-collision warning timing**

The pre-collision warning timing can be changed on the  screen (→P.177) of the multi-information display.

The warning timing setting is retained when the power switch is turned to OFF. However, if the pre-collision system is disabled and re-enabled, the operation timing will return to the default setting (middle).

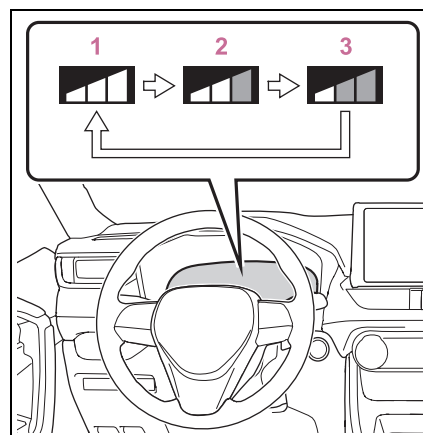

- 1 Early
- 2 Middle
- 3 Late

This is the default setting.

Operational conditions

The pre-collision system is enabled and the system determines that the possibility of a frontal collision with a detected object is high. Each function is operational at the following speed

● Pre-collision warning

Detectable objects	Vehicle speed	Relative speed between your vehicle and object
Vehicles	Approx. 10 to 180 km/h (7 to 110 mph)	Approx. 10 to 180 km/h (7 to 110 mph)
Bicyclists and pedestrians	Approx. 10 to 80 km/h (7 to 50 mph)	Approx. 10 to 80 km/h (7 to 50 mph)

● Pre-collision brake assist

Detectable objects	Vehicle speed	Relative speed between your vehicle and object
Vehicles	Approx. 30 to 180 km/h (20 to 110 mph)	Approx. 30 to 180 km/h (20 to 110 mph)
Bicyclists and pedestrians	Approx. 30 to 80 km/h (20 to 50 mph)	Approx. 30 to 80 km/h (20 to 50 mph)

● Pre-collision braking

Detectable objects	Vehicle speed	Relative speed between your vehicle and object
Vehicles	Approx. 10 to 180 km/h (7 to 110 mph)	Approx. 10 to 180 km/h (7 to 110 mph)
Bicyclists and pedestrians	Approx. 10 to 80 km/h (7 to 50 mph)	Approx. 10 to 80 km/h (7 to 50 mph)

The system may not operate in the following situations:

- If a 12-volt battery terminal has been disconnected and reconnected and then the vehicle has not been driven for a certain amount of time
- If the shift lever is in R
- When the VSC OFF indicator is illuminated (only the pre-collision warning function will be operational)

■ **Object detection function**

The system detects objects based on their size, profile, motion, etc. However, an object may not be detected depending on the surrounding brightness and the motion, posture, and angle of the detected object, preventing the system from operating properly. (→P.321)
The illustration shows an image of detectable objects.

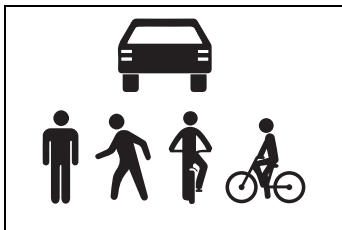

■ **Cancellation of the pre-collision braking**

If either of the following occur while the pre-collision braking function is operating, it will be canceled:

- The accelerator pedal is depressed strongly.
- The steering wheel is turned sharply or abruptly.

■ **Conditions under which the system may operate even if there is no possibility of a collision**

- In some situations such as the following, the system may determine that there is a possibility of a frontal collision and operate.
 - When passing a detectable object, etc.
 - When changing lanes while overtaking a detectable object, etc.
 - When approaching a detectable object in an adjacent lane or on the roadside, such as when changing the course of travel or driving on a winding road

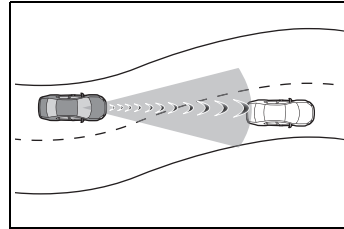

- When rapidly closing on a detectable object, etc.
- When approaching objects on the roadside, such as detectable objects, guardrails, utility poles, trees, or walls
- When there is a detectable object or other object by the roadside at the entrance of a curve

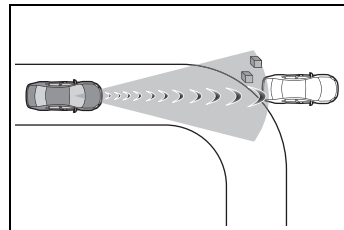

- When there are patterns or paint in front of your vehicle that may be mistaken for a detectable object
- When the front of your vehicle is hit by water, snow, dust, etc.
- When overtaking a detectable object that is changing lanes or making a right/left turn

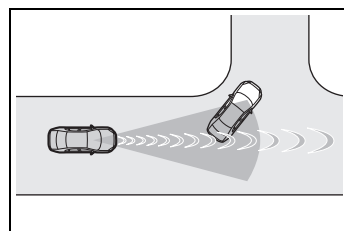

- When passing a detectable object in an oncoming lane that is stopped to make a right/left turn

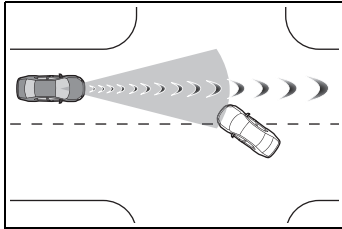

- When a detectable object approaches very close and then stops before entering the path of your vehicle
- If the front of your vehicle is raised or lowered, such as when on an uneven or undulating road surface
- When driving on a road surrounded by a structure, such as in a tunnel or on an iron bridge
- When there is a metal object (manhole cover, steel plate, etc.), steps, or a protrusion in front of your vehicle
- When passing under an object (road sign, billboard, etc.)

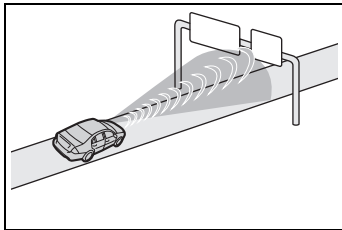

- When approaching an electric toll gate barrier, parking area barrier, or other barrier that opens and closes
- When using an automatic car wash
- When driving through or under objects that may contact your vehicle, such as thick grass, tree branches, or a banner

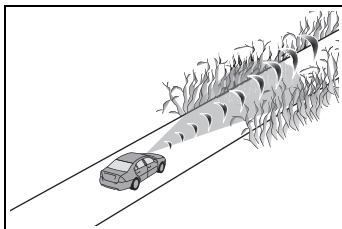

- When driving through steam or smoke
- When driving near an object that

- reflects radio waves, such as a large truck or guardrail
- When driving near a TV tower, broadcasting station, electric power plant, or other location where strong radio waves or electrical noise may be present

■ **Situations in which the system may not operate properly**

- In some situations such as the following, an object may not be detected by the radar sensor and front camera, preventing the system from operating properly:
 - When a detectable object is approaching your vehicle
 - When your vehicle or a detectable object is wobbling
 - If a detectable object makes an abrupt maneuver (such as sudden swerving, acceleration or deceleration)
 - When your vehicle approaches a detectable object rapidly
 - When a detectable object is not directly in front of your vehicle

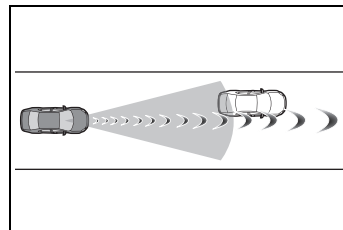

- When a detectable object is near a wall, fence, guardrail, manhole cover, vehicle, steel plate on the road, etc.
- When a detectable object is under a structure
- When part of a detectable object is hidden by an object, such as large baggage, an umbrella, or guardrail
- When multiple detectable objects are close together
- If the sun or other light is shining directly on a detectable object
- When a detectable object is a shade of white and looks extremely bright
- When a detectable object appears to be nearly the same color or brightness as its surroundings

- If a detectable object cuts or suddenly emerges in front of your vehicle
- When the front of your vehicle is hit by water, snow, dust, etc.
- When a very bright light ahead, such as the sun or the headlights of oncoming traffic, shines directly into the front camera
- When approaching the side or front of a vehicle ahead
- If a vehicle ahead is a motorcycle
- If a vehicle ahead is narrow, such as a personal mobility vehicle
- If a preceding vehicle has a small rear end, such as an unloaded truck
- If a preceding vehicle has a low rear end, such as a low bed trailer

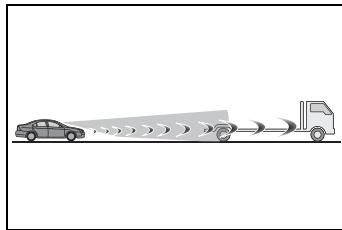

- If a vehicle ahead has extremely high ground clearance

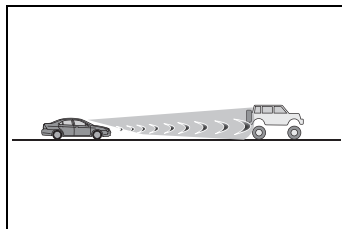

- If a vehicle ahead is carrying a load which protrudes past its rear bumper
- If a vehicle ahead is irregularly shaped, such as a tractor or side car
- If a vehicle ahead is a child sized bicycle, a bicycle that is carrying a large load, a bicycle ridden by more than one person, or a uniquely shaped bicycle (bicycle with a child seat, tandem bicycle, etc.)
- If a pedestrian/or the riding height of a bicyclist ahead is shorter than approximately 1 m (3.2 ft.) or taller than approximately 2 m (6.5 ft.)

- If a pedestrian/bicyclist is wearing oversized clothing (a rain coat, long skirt, etc.), making their silhouette obscure
- If a pedestrian is bending forward or squatting or bicyclist is bending forward
- If a pedestrian/bicyclist is moving fast
- If a pedestrian is pushing a stroller, wheelchair, bicycle or other vehicle
- When driving in inclement weather such as heavy rain, fog, snow or a sandstorm
- When driving through steam or smoke
- When the surrounding area is dim, such as at dawn or dusk, or while at night or in a tunnel, making a detectable object appear to be nearly the same color as its surroundings
- When driving in a place where the surrounding brightness changes suddenly, such as at the entrance or exit of a tunnel
- After the hybrid system has started the vehicle has not been driven for a certain amount of time
- While making a left/right turn and for a few seconds after making a left/right turn
- While driving on a curve and for a few seconds after driving on a curve
- If your vehicle is skidding
- If the front of the vehicle is raised or lowered

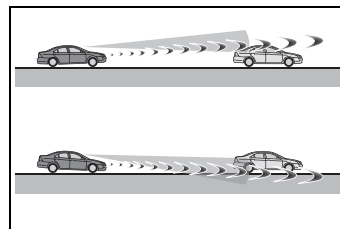

- If the wheels are misaligned
- If a wiper blade is blocking the front camera
- The vehicle is being driven at extremely high speeds
- When driving on a hill
- If the radar sensor or front camera is misaligned

- In some situations such as the following, sufficient braking force may not be obtained, preventing the system from performing properly:
 - If the braking functions cannot operate to their full extent, such as when the brake parts are extremely cold, extremely hot, or wet
 - If the vehicle is not properly maintained (brakes or tires are excessively worn, improper tire inflation pressure, etc.)
 - When the vehicle is being driven on a gravel road or other slippery surface
- **If VSC is disabled**
 - If VSC is disabled (→P.394), the pre-collision brake assist and pre-collision braking functions are also disabled.
 - The PCS warning light will turn on and “VSC Turned OFF Pre-Collision Brake System Unavailable” will be displayed on the multi-information display.

LTA (Lane Tracing Assist)

When driving on highways and freeways with white (yellow) lane lines, this function alerts the driver when the vehicle might depart from its lane or course* and provides assistance by operating the steering wheel to keep the vehicle in its lane or course*. Furthermore, the system provides steering assistance when dynamic radar cruise control with full-speed range is operating to keep the vehicle in its lane.

The LTA system recognizes white (yellow) lane lines or a course* using the front camera. Additionally, it detects preceding vehicles using the front camera and radar.

*: Boundary between asphalt and the side of the road, such as grass, soil, or a curb

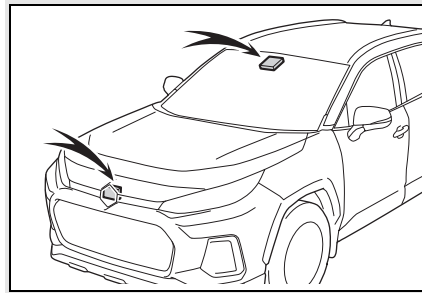



WARNING

■ **Before using LTA system**

- Do not rely solely upon the LTA system. The LTA system does not automatically drive the vehicle or reduce the amount of attention that must be paid to the area in front of the vehicle. The driver must always assume full responsibility for driving safely by paying careful attention to the surrounding conditions and operating the steering wheel to correct the path of the vehicle. Also, the driver must take adequate breaks when fatigued, such as from driving for a long period of time.
- Failure to perform appropriate driving operations and pay careful attention may lead to an accident, resulting in death or serious injury.
- When not using the LTA system, use the LTA switch to turn the system off.

■ **Situations unsuitable for LTA system**

In the following situations, use the LTA switch to turn the system off. Failure to do so may lead to an accident, resulting in death or serious injury.

- Vehicle is driven on a road surface which is slippery due to rainy weather, fallen snow, freezing, etc.
- Vehicle is driven on a snow-covered road.
- White (yellow) lines are difficult to see due to rain, snow, fog, dust, etc.
- Vehicle is driven in a temporary lane or restricted lane due to construction work.
- Vehicle is driven in a construction zone.
- A spare tire, tire chains, etc. are equipped.

- When the tires have been excessively worn, or when the tire inflation pressure is low.

- When tires of a size other than specified are installed.

- Vehicle is driven in traffic lanes other than that highways and free-ways.

- When your vehicle is towing a trailer or during emergency towing

■ **Preventing LTA system malfunctions and operations performed by mistake**

- Do not modify the headlights or place stickers, etc. on the surface of the lights.

- Do not modify the suspension etc. If the suspension etc. needs to be replaced, contact a SUZUKI dealer or a qualified workshop.

- Do not install or place anything on the hood or grille. Also, do not install a grille guard (bull bars, kangaroo bar, etc.).

- If your windshield needs repairs, contact a SUZUKI dealer or a qualified workshop.

■ **Conditions in which functions may not operate properly**

In the following situations, the functions may not operate properly and the vehicle may depart from its lane. Drive safely by always paying careful attention to your surroundings and operate the steering wheel to correct the path of the vehicle without relying solely on the functions.

WARNING

- When the follow-up cruising display is displayed (→P.329) and the preceding vehicle changes lanes. (Your vehicle may follow the preceding vehicle and also change lanes.)

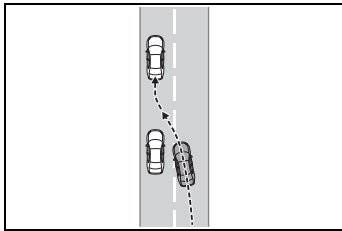

- When the follow-up cruising display is displayed (→P.329) and the preceding vehicle is swaying. (Your vehicle may sway accordingly and depart from the lane.)
- When the follow-up cruising display is displayed (→P.329) and the preceding vehicle departs from its lane. (Your vehicle may follow the preceding vehicle and depart from the lane.)
- When the follow-up cruising display is displayed (→P.329) and the preceding vehicle is being driven extremely close to the left/right lane line. (Your vehicle may follow the preceding vehicle and depart from the lane.)
- Vehicle is being driven around a sharp curve.

- Objects or patterns that could be mistaken for white (yellow) lines are present on the side of the road (guardrails, reflective poles, etc.).

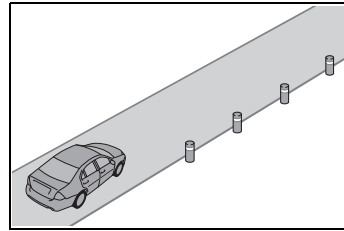

- Vehicle is driven where the road diverges, merges, etc.

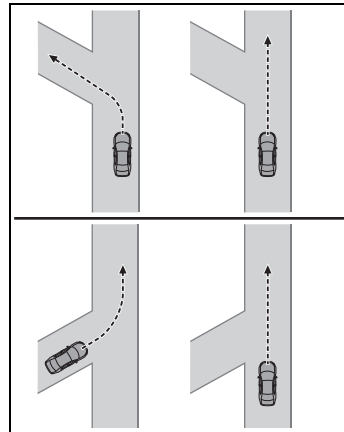

- Repair marks of asphalt, white (yellow) lines, etc. are present due to road repair.

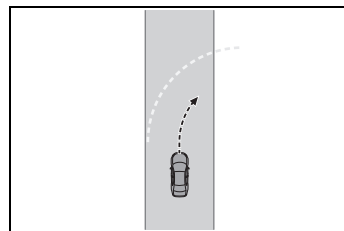

- There are shadows on the road that run parallel with, or cover, the white (yellow) lines.



WARNING

- The vehicle is driven in an area without white (yellow) lines, such as in front of a tollgate or checkpoint, or at an intersection, etc.
- The white (yellow) lines are cracked, “Raised pavement marker” or stones are present.
- The white (yellow) lines cannot be seen or are difficult to see due to sand, etc.
- The vehicle is driven on a road surface that is wet due to rain, puddles, etc.
- The traffic lines are yellow (which may be more difficult to recognize than lines that are white).
- The white (yellow) lines cross over a curb, etc.
- The vehicle is driven on a bright surface, such as concrete.
- If the edge of the road is not clear or straight.
- The vehicle is driven on a surface that is bright due to reflected light, etc.
- The vehicle is driven in an area where the brightness changes suddenly, such as at the entrances and exits of tunnels, etc.
- Light from the headlights of an oncoming vehicle, the sun, etc. enters the camera.
- The vehicle is driven on a slope.
- The vehicle is driven on a road which tilts left or right, or a winding road.
- The vehicle is driven on an unpaved or rough road.
- The traffic lane is excessively narrow or wide.

- The vehicle is extremely tilted due to carrying heavy luggage or having improper tire pressure.
- The distance to the preceding vehicle is extremely short.
- The vehicle is moving up and down a large amount due to road conditions during driving (poor roads or road seams).
- When driving in a tunnel or at night with the headlights off or when a headlight is dim due to its lens being dirty or it being misaligned.
- The vehicle is struck by a crosswind.
- The vehicle is affected by wind from a vehicle driven in a nearby lane.
- The vehicle has just changed lanes or crossed an intersection.
- Tires which differ by structure, manufacturer, brand or tread pattern are used.
- Snow tires, etc. are equipped.
- The vehicle is being driven at extremely high speeds.

Functions included in LTA system

■ **Lane departure alert function**

When the system determines that the vehicle might depart from its lane or course*, a warning is displayed on the multi-information display, and either a warning buzzer will sound or the steering wheel will vibrate to alert the driver.

When the warning buzzer sounds or the steering wheel vibrates, check the area around your vehicle and carefully

operate the steering wheel to move the vehicle back to the center of the lane.

When the system determines that the vehicle might depart from its lane and that the possibility of a collision with an overtaking vehicle in the adjacent lane is high, the lane departure alert will operate even if the turn signals are operating.

*: Boundary between asphalt and the side of the road, such as grass, soil, or a curb

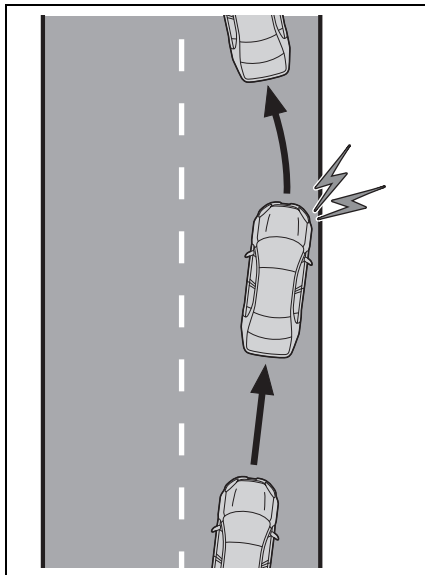

■ **Steering assist function**

When the system determines that the vehicle might depart from its lane or course*, the system provides assistance as necessary by operating the steering wheel in small amounts for a short period of time to keep the vehicle in its lane.

If the system detects that the steering wheel has not been operated for a fixed amount of time or the steering wheel is

not being firmly gripped, a warning is displayed on the multi-information display and the function is temporarily canceled.

When the system determines that the vehicle might depart from its lane and that the possibility of a collision with an overtaking vehicle in the adjacent lane is high, the steering assist function will operate even if the turn signals are operating.

*: Boundary between asphalt and the side of the road, such as grass, soil, or a curb

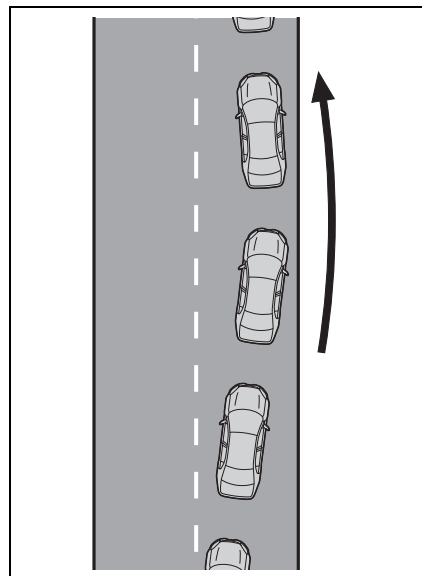

■ **Vehicle sway warning function**

When the vehicle is swaying within a lane, the warning buzzer will sound and a message will be displayed on the multi-information display to alert the driver.

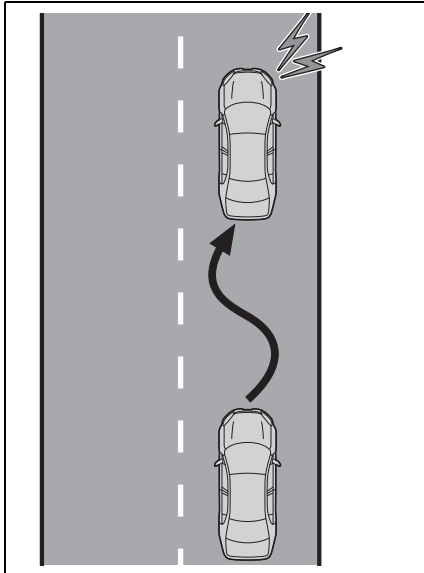

■ Lane centering function

This function is linked with dynamic radar cruise control with full-speed range and provides the required assistance by operating the steering wheel to keep the vehicle in its current lane.

When dynamic radar cruise control with full-speed range is not operating, the lane centering function does not operate.

In situations where the white (yellow) lane lines are difficult to see or are not visible, such as when in a traffic jam, this function will operate to help follow a preceding vehicle by monitoring the position of the preceding vehicle.

If the system detects that the steering wheel has not been operated for a fixed amount of time or the steering wheel is not being firmly gripped, a warning is displayed on the multi-information display and the function is temporarily canceled.

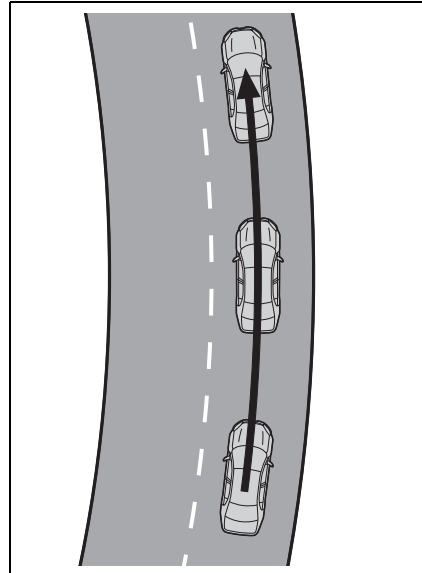

Turning LTA system on

Press the LTA switch to turn the LTA system on.

The LTA indicator illuminates and a message is displayed on the multi-information display.

Press the LTA switch again to turn the LTA system off.

When the LTA system is turned on or off, operation of the LTA system continues in the same condition the next time the hybrid system is started.

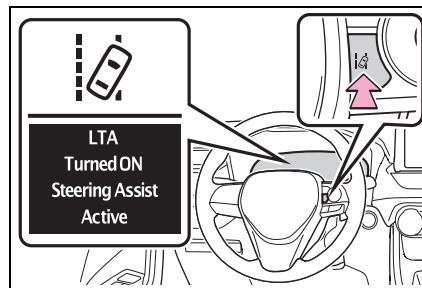

Indications on multi-information display

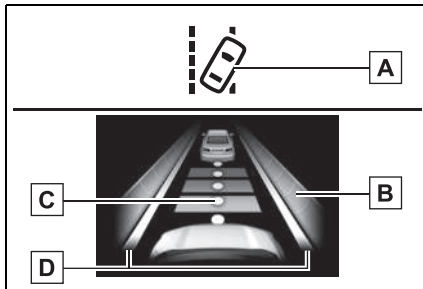

A LTA indicator

The illumination condition of the indicator informs the driver of the system operation status.

Illuminated in white: LTA system is operating.

Illuminated in green: Steering wheel assistance of the steering assist function or lane centering function is operating.

Flashing in orange: Lane departure alert function is operating.

B Operation display of steering wheel operation support

Displayed when the multi-information display is switched to the driving support system information display.

Indicates that steering wheel assistance of the steering assist function or lane centering function is operating.

Both outer sides of the lane are displayed: Indicates that steering wheel assist of the lane centering function is operating.

One outer side of the lane is displayed: Indicates that steering wheel assist of the steering assist function is operating.

Both outer sides of the lane are flashing: Alerts the driver that their input is necessary to stay in the center of the lane (lane centering function).

C Follow-up cruising display

Displayed when the multi-information display is switched to the driving support system information display.

Indicates that steering assist of the lane centering function is operating by monitoring the position of a preceding vehicle.

When the follow-up cruising display is displayed, if the preceding vehicle moves, your vehicle may move in the same way. Always pay careful attention to your surroundings and operate the steering wheel as necessary to correct the path of the vehicle and ensure safety.

D Lane departure alert function display

Displayed when the multi-information display is switched to the driving support system information display.

- ▶ Inside of displayed lines is white

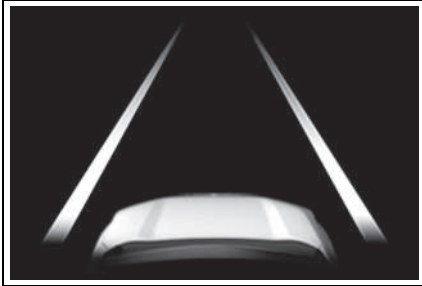

Indicates that the system is recognizing white (yellow) lines or a course*. When the vehicle departs from its lane, the white line displayed on the side the vehicle departs from flashes orange.

- ▶ Inside of displayed lines is black

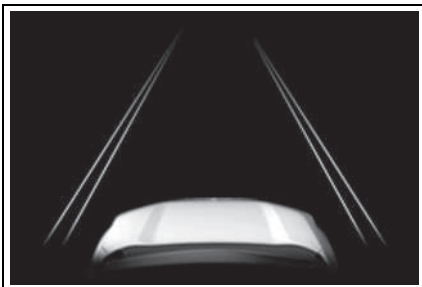

Indicates that the system is not able to recognize white (yellow) lines or a course* or is temporarily canceled.

*: Boundary between asphalt and the side of the road, such as grass, soil, or a curb

■ Operation conditions of each function

- Lane departure alert function

This function operates when all of the following conditions are met.

- LTA is turned on.
- Vehicle speed is approximately 50 km/h (32 mph) or more.*¹
- System recognizes white (yellow) lane

lines or a course*². (When a white [yellow] line or course*² is recognized on only one side, the system will operate only for the recognized side.)

- Width of traffic lane is approximately 3 m (9.8 ft.) or more.
- Turn signal lever is not operated. (Except when another vehicle is in the lane on the side where the turn signal was operated)
- Vehicle is not being driven around a sharp curve.
- No system malfunctions are detected. (→P.332)

*¹: The function operates even if the vehicle speed is less than approximately 50 km/h (32 mph) when the lane centering function is operating.

*²: Boundary between asphalt and the side of the road, such as grass, soil, or a curb

- Steering assist function

This function operates when all of the following conditions are met in addition to the operation conditions for the lane departure alert function.

- Setting for "Steering Assist" in the  screen of the multi-information display is set to "ON". (→P.171)
- Vehicle is not accelerated or decelerated by a fixed amount or more.
- Steering wheel is not operated with a steering force level suitable for changing lanes.
- ABS, VSC, TRC and PCS are not operating.
- TRC or VSC is not turned off.
- Hands off steering wheel warning is not displayed. (→P.331)

- Vehicle sway warning function

This function operates when all of the following conditions are met.

- Setting for "Sway Warning" in the  screen of the multi-information display is set to "ON". (→P.171)
- Vehicle speed is approximately 50

- km/h (32 mph) or more.
 - Width of traffic lane is approximately 3 m (9.8 ft.) or more.
 - No system malfunctions are detected. (→P.332)
 - Lane centering function
- This function operates when all of the following conditions are met.
- LTA is turned on.
 - Setting for “Steering Assist” and “Lane Center” in the  screen of the multi-information display are set to “ON”. (→P.171)
 - This function recognizes white (yellow) lane lines or the position of a preceding vehicle (except when the preceding vehicle is small, such as a motorcycle).
 - The dynamic radar cruise control with full-speed range is operating in vehicle-to-vehicle distance control mode.
 - Width of traffic lane is approximately 3 to 4 m (10 to 13 ft.).
 - Turn signal lever is not operated.
 - Vehicle is not being driven around a sharp curve.
 - No system malfunctions are detected. (→P.332)
 - Vehicle does not accelerate or decelerate by a fixed amount or more.
 - Steering wheel is not operated with a steering force level suitable for changing lanes.
 - ABS, VSC, TRC and PCS are not operating.
 - TRC or VSC is not turned off.
 - Hands off steering wheel warning is not displayed. (→P.331)
 - The vehicle is being driven in the center of a lane.
 - Steering assist function is not operating.
- **Temporary cancelation of functions**
- When operation conditions are no longer met, a function may be temporarily canceled. However, when the operation conditions are met again, operation of the function is automatically restored. (→P.330)
 - If the operation conditions (→P.330)

are no longer met while the lane centering function is operating, the steering wheel may vibrate and the buzzer may sound to indicate that the function has been temporarily canceled. However, if the “Alert” customization setting is set to “Steering wheel vibration”, the system will notify the driver by vibrating the steering wheel instead of sounding the buzzer.

■ **Steering assist function/lane centering function**

- Depending on the vehicle speed, lane departure situation, road conditions, etc., the driver may not feel the function is operating or the function may not operate at all.
- The steering control of the function is overridden by the driver’s steering wheel operation.
- Do not attempt to test the operation of the steering assist function.

■ **Lane departure alert function**

- The warning buzzer may be difficult to hear due to external noise, audio playback, etc. Also, it may be difficult to feel steering wheel vibrations due to the road conditions, etc.
- If the edge of the course* is not clear or straight, the lane departure alert function may not operate.
- It may not be possible for the system to determine if there is a danger of a collision with a vehicle in an adjacent lane.
- Do not attempt to test the operation of the lane departure alert function.

*: Boundary between asphalt and the side of the road, such as grass, soil, or a curb

■ **Hands off steering wheel warning**

In the following situations, a warning message urging the driver to hold the steering wheel and the symbol shown in the illustration are displayed on the multi-information display to warn the driver. The warning stops when the sys-

tem determines that the driver holds the steering wheel. Always keep your hands on the steering wheel when using this system, regardless of warnings.



- When the system determines that the driver is driving without holding the steering wheel while the system is operating

If the driver continues to keep their hands off of the steering wheel, the buzzer sounds, the driver is warned and the function is temporarily canceled. This warning also operates in the same way when the driver continuously operates the steering wheel only a small amount.

The buzzer also sounds even if the alert type is set to “Steering wheel vibration”.

- When the system determines that the vehicle may not turn and instead depart from its lane while driving around a curve

Depending on the vehicle condition and road conditions, the warning may not operate. Also, if the system determines that the vehicle is driving around a curve, warnings will occur earlier than during straight-lane driving.

- When the system determines that the driver is driving without holding the steering wheel while the steering wheel assist of the steering assist function is operating.

If the driver continues to keep their hands off of the steering wheel and the steering wheel assist is operating, the buzzer sounds and the driver is warned. Each time the buzzer sounds, the con-

tinuing time of the buzzer becomes longer.

The buzzer also sounds even if the alert type is set to “Steering wheel vibration”.

■ **Vehicle sway warning function**

When the system determines that the vehicle is swaying while the vehicle sway warning function is operating, a buzzer sounds and a warning message urging the driver to rest and the symbol shown in the illustration are simultaneously displayed on the multi-information display.



Depending on the vehicle and road conditions, the warning may not operate.

■ **Warning message**

If the following warning message is displayed on the multi-information display and the LTA indicator illuminates in orange, follow the appropriate troubleshooting procedure. Also, if a different warning message is displayed, follow the instructions displayed on the screen.

- “LTA Malfunction Visit Your Dealer”
The system may not be operating properly. Have the vehicle inspected by a SUZUKI dealer or a qualified workshop.
- “LTA Unavailable”
The system is temporarily canceled due to a malfunction in a sensor other than the front camera. Turn the LTA system off, wait for a little while, and then turn the LTA system back on.
- “LTA Unavailable at Current Speed”
The function cannot be used as the vehicle speed exceeds the LTA operation range. Drive slower.

■ Customization

Function settings can be changed.
(→P.177)

RSA (Road Sign Assist)

The RSA system recognizes specific road signs using the front camera to provide information to the driver via the display.

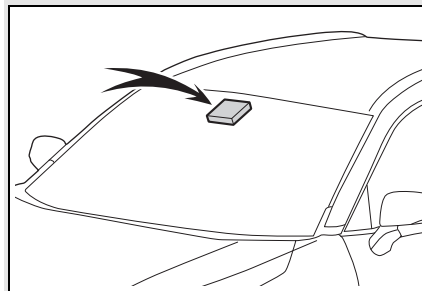

If the system judges that the vehicle is being driven over the speed limit, performing prohibited actions, etc. according to the recognized road signs, it notifies the driver through a visual notification and notification buzzer or steering wheel vibration.

**WARNING****■ Before using the RSA**

Do not rely solely upon the RSA system. RSA is a system which supports the driver by providing information, but it is not a replacement for a driver's own vision and awareness. Drive safely by always paying careful attention to the traffic rules.

Indication on the multi-information display

When the front camera recognizes a sign, the sign will be displayed on

the multi-information display.

- When the driving support system information display is selected, a maximum of 3 signs can be displayed. (→P.171)

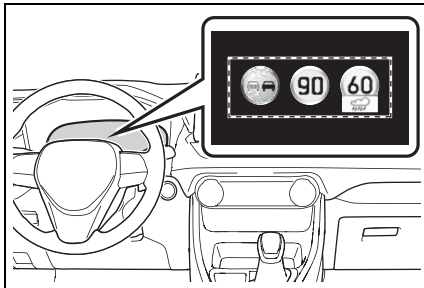

- When a tab other than the driving support system information display is selected, the following types of road signs will be displayed. (→P.171)
 - Speed limit begins/ends sign
 - Speed limit related information sign (Expressway, Highway, Urban area, Residential area)
 - All canceled sign
 - Speed limit with supplemental sign (Ramp way only)

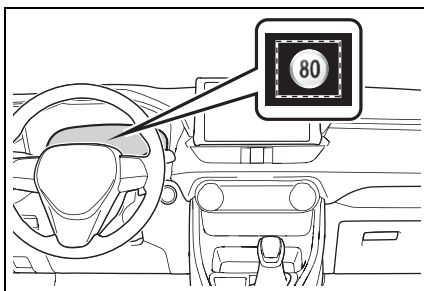

If signs other than speed limit signs are recognized, they will be displayed in an overlapping stack under the current speed limit sign.

Supported types of road signs

The following types of road signs, including electronic signs and blinking signs, are recognized.

A non-official (not meeting the Vienna Convention) or a recently introduced traffic sign may not be recognized.

- Speed limit road signs



Speed limit begins/Maximum speed zone begins



Speed limit ends/Maximum speed zone ends

- Speed limit related information



Expressway entrance



Expressway exit



Highway entrance



Highway exit



Urban area beginning



Urban area ending

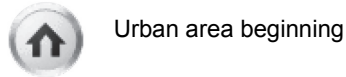

Urban area beginning



Urban area ending



Residential area beginning



Residential area ending

- No-overtaking road signs



No overtaking begins



No overtaking ends

- Other road signs



End of prohibition



Stop

- Speed limit with supplemental mark^{*1}



Wet



Rain



Ice

Supplemental mark exists^{*2}Exit ramp on right^{*3}Exit ramp on left^{*3}

Time

^{*1}: Displayed simultaneously with speed limit

^{*2}: Contents not recognized.

^{*3}: If the turn signal indicator is not operated when changing lanes, the mark does not display.

Notification function

In the following situations, the RSA system will notify the driver.

- When the vehicle speed exceeds the speed notification threshold of the speed limit sign displayed, the sign display will be emphasized and a buzzer will sound.
- If it is detected that your vehicle is overtaking when a no overtaking sign is displayed on the multi-information display, the displayed sign will flash and a steering wheel will vibrate.

Depending on the situation, traffic environment (traffic direction, speed unit) may be detected incorrectly and a notification function may not operate properly.

Setting procedure

→P.177

■ **Automatic turn-off of RSA sign display**

One or more signs automatically turn off in the following situations.

- No sign has been recognized for a certain distance.
- The road changes due to a left or right turn, etc.

■ **Conditions in which the function may not operate or detect correctly**

In the following situations, RSA does not operate normally and may not recognize signs, display the incorrect sign, etc. However, this does not indicate a malfunction.

- The front camera is misaligned due to a strong impact being applied to the sensor, etc.
- Dirt, snow, stickers, etc. are on the windshield near the front camera.
- In inclement weather such as heavy rain, fog, snow or sand storms.
- Light from an oncoming vehicle, the sun, etc. enters the front camera.
- The sign is dirty, faded, tilted or bent.
- The contrast of electronic sign is low.
- All or part of the sign is hidden by the leaves of a tree, a pole, etc.
- The sign is only visible to the front camera for a short amount of time.
- The driving scene (turning, lane change, etc.) is judged incorrectly.
- If a sign not appropriate for the currently traveled lane, but the sign exists directly after a freeway branches, or in an adjacent lane just before merging.
- Stickers are attached to the rear of the preceding vehicle.
- A sign resembling a system compatible sign is recognized.
- Side road speed signs may be detected and displayed (if positioned in sight of the front camera) while the vehicle is traveling on the main road.
- Roundabout exit road speed signs

may be detected and displayed (if positioned in sight of the front camera) while traveling on a roundabout.

- The front of the vehicle is raised or lowered due to the carried load.
- The surrounding brightness is not sufficient or changes suddenly.
- When a sign intended for trucks, etc. is recognized.
- The vehicle is driven in a country with a different direction of traffic.
- The speed information displayed on the meter and on the navigation system may be different due to the navigation system using map data.

■ **Speed limit sign display**

If the power switch was last turned off while a speed limit sign was displayed on the multi-information display, the same sign displays again when the power switch is turned to ON.

■ **If “RSA Malfunction Visit Your Dealer” is shown**

The system may be malfunctioning. Have the vehicle inspected by a SUZUKI dealer or a qualified workshop.

■ **Customization**

Some functions can be customized. (Customizable features: →P.177)

Dynamic radar cruise control with full-speed range

In vehicle-to-vehicle distance control mode, the vehicle automatically accelerates, decelerates and stops to match the speed changes of the preceding vehicle even if the accelerator pedal is not depressed. In constant speed control mode, the vehicle runs at a fixed speed.

Use the dynamic radar cruise control with full-speed range on freeways and highways.

- Vehicle-to-vehicle distance control mode (→P.340)
- Constant speed control mode (→P.344)

System Components

■ Meter display

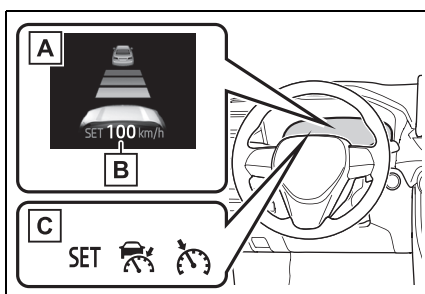

- A** Multi-information display
- B** Set speed
- C** Indicators

■ Operation switches

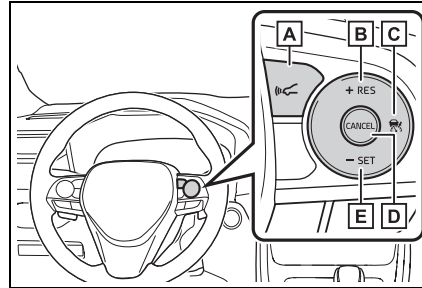

- A** Vehicle-to-vehicle distance switch
- B** "+RES" switch
- C** Cruise control main switch
- D** Cancel switch
- E** "-SET" switch

⚠ WARNING

■ Before using dynamic radar cruise control with full-speed range

- Driving safely is the sole responsibility of the driver. Do not rely solely on the system, and drive safely by always paying careful attention to your surroundings.
- The dynamic radar cruise control with full-speed range provides driving assistance to reduce the driver's burden. However, there are limitations to the assistance provided.

Read the following conditions carefully. Do not overly rely on this system and always drive carefully.

- When the sensor may not be correctly detecting the vehicle ahead:→P.347

- Conditions under which the vehicle-to-vehicle distance control mode may not function correctly:→P.348
- Set the speed appropriately depending on the speed limit, traffic flow, road conditions, weather conditions, etc. The driver is responsible for checking the set speed.
- Even when the system is functioning normally, the condition of the preceding vehicle as detected by the system may differ from the condition observed by the driver. Therefore, the driver must always remain alert, assess the danger of each situation and drive safely. Relying solely on this system or assuming the system ensures safety while driving can lead to an accident, resulting in death or serious injury.
- Switch the dynamic radar cruise control with full-speed range setting to off, using the cruise control main switch when not in use.



WARNING

■ **Cautions regarding the driving assist systems**

Observe the following precautions, as there are limitations to the assistance provided by the system. Failure to do so may cause an accident resulting in death or serious injury.

- **Assisting the driver to measure following distance**

The dynamic radar cruise control with full-speed range is only intended to help the driver in determining the following distance between the driver's own vehicle and a designated vehicle traveling ahead. It is not a mechanism that allows careless or inattentive driving, and it is not a system that can assist the driver in low-visibility conditions.

It is still necessary for driver to pay close attention to the vehicle's surroundings.

- **Assisting the driver to judge proper following distance**

The dynamic radar cruise control with full-speed range determines whether the following distance between the driver's own vehicle and a designated vehicle traveling ahead is within a set range. It is not capable of making any other type of judgement. Therefore, it is absolutely necessary for the driver to remain vigilant and to determine whether or not there is a possibility of danger in any given situation.

- Assisting the driver to operate the vehicle

The dynamic radar cruise control with full-speed range does not include functions which will prevent or avoid collisions with vehicles ahead of your vehicle. Therefore, if there is ever any possibility of danger, the driver must take immediate and direct control of the vehicle and act appropriately in order to ensure the safety of all involved.

■ **Situations unsuitable for dynamic radar cruise control with full-speed range**

Do not use dynamic radar cruise control with full-speed range in any of the following situations. Doing so may result in inappropriate speed control and could cause an accident resulting in death or serious injury.

- Roads where there are pedestrians, cyclists, etc.
- In heavy traffic
- On roads with sharp bends
- On winding roads
- On slippery roads, such as those covered with rain, ice or snow
- On steep downhill, or where there are sudden changes between sharp up and down gradients

Vehicle speed may exceed the set speed when driving down a steep hill.

- At entrances to freeways and highways
- When weather conditions are bad enough that they may prevent the sensors from detecting correctly (fog, snow, sandstorm, heavy rain, etc.)



WARNING

- When there is rain, snow, etc. on the front surface of the radar or front camera
- In traffic conditions that require frequent repeated acceleration and deceleration
- When your vehicle is towing a trailer or during emergency towing
- When an approach warning buzzer is heard often

Driving in vehicle-to-vehicle distance control mode

This mode employs a radar to detect the presence of vehicles up to approximately 100 m (328 ft.) ahead, determines the current vehicle-to-vehicle following distance, and operates to maintain a suitable following distance from the vehicle ahead. The desired vehicle-to-vehicle distance can also be set by operating the vehicle-to-vehicle distance switch.

When driving on downhill slopes, the vehicle-to-vehicle distance may become shorter.

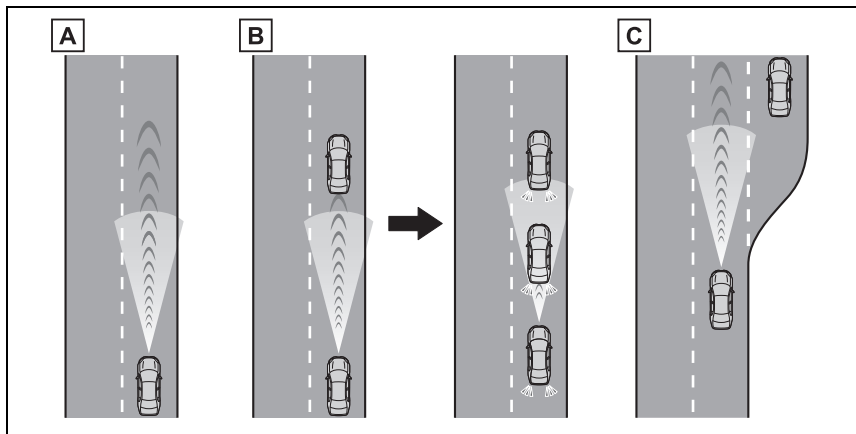

A Example of constant speed cruising

When there are no vehicles ahead

The vehicle travels at the speed set by the driver.

B Example of deceleration cruising and follow-up cruising

When a preceding vehicle driving slower than the set speed appears

When a vehicle is detected running ahead of you, the system automatically decelerates your vehicle. When a greater reduction in vehicle speed is necessary, the system applies the brakes (the stop lights will come on at this time). The system will respond to changes in the speed of the vehicle ahead in order to maintain the vehicle-to-vehicle distance set by the driver. Approach warning warns you when the system cannot decelerate sufficiently to prevent your vehicle from closing in on the vehicle ahead.

When the vehicle ahead of you stops, your vehicle will also stop (vehicle is stopped by system control). After the vehicle ahead starts off, pressing the "+RES" switch or depressing the accelerator pedal (start-off operation) will resume follow-up cruising. If the start-off operation is not performed, system control continues to keep your vehicle stopped.

When the turn signal lever is operated and your vehicle moves to an overtaking lane while driving at 50 mph (80 km/h) or more, the vehicle will accelerate to help to overtake a passing vehicle.

The system's identification of what is an overtaking lane may be determined solely based on the location of the steering wheel in the vehicle (left side driver position versus right side driver position.) If the vehicle is driven to a region where the overtaking lane is on a different side from where the vehicle is normally driven, the vehicle may accelerate when the turn signal lever is operated in the opposite direction to the overtaking lane (e.g., if the driver normally operates the vehicle in a region where the overtaking lane is to the right but then drives to a region where the overtaking lane is to the left, the vehicle may accelerate when the right turn signal is activated).

C Example of acceleration

When there are no longer any preceding vehicles driving slower than the set speed

The system accelerates until the set speed is reached. The system then returns to constant speed cruising.

Setting the vehicle speed (vehicle-to-vehicle distance control mode)

- 1 Press the cruise control main switch to activate the cruise control.

Dynamic radar cruise control indicator will come on and a message will be displayed on the multi-information display. Press the switch again to deactivate the cruise control.

If the cruise control main switch is pressed and held for 1.5 seconds or more, the system turns on in constant speed control mode. (→P.344)

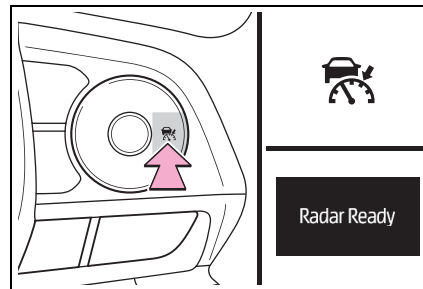

- 2 Accelerate or decelerate, with accelerator pedal operation, to the desired vehicle speed (at or above approximately 30 km/h [20 mph]) and press the “-SET” switch to set the speed.

Cruise control “SET” indicator will come on.

The vehicle speed at the moment the switch is released becomes the set

speed.

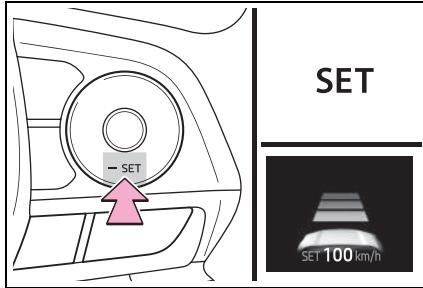

Adjusting the set speed

- Adjusting the set speed by the switch

To change the set speed, press the “+RES” or “-SET” switch until the desired set speed is displayed.

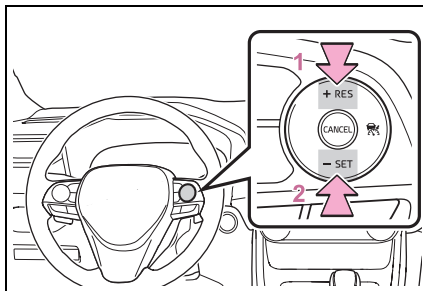

- 1 Increases the speed (Except when the vehicle has been stopped by system control in vehicle-to-vehicle distance control mode)
- 2 Decreases the speed

Fine adjustment: Press the switch.
Large adjustment: Press and hold the switch to change the speed, and release when the desired speed is reached.

In the vehicle-to-vehicle distance control mode, the set speed will be

increased or decreased as follows:

Fine adjustment: By 1 km/h (0.6 mph)^{*1} or 1 mph (1.6 km/h)^{*2} each time the switch is pressed

Large adjustment: Increases or decreases in 5 km/h (3.1 mph)^{*1} or 5 mph (8 km/h)^{*2} increments for as long as the switch is held

In the constant speed control mode (→P.344), the set speed will be increased or decreased as follows:

Fine adjustment: By 1 km/h (0.6 mph)^{*1} or 1 mph (1.6 km/h)^{*2} each time the switch is pressed

Large adjustment: The speed will continue to change while the switch is held.

^{*1}: When the set speed is shown in “km/h”

^{*2}: When the set speed is shown in “MPH”

- Increasing the set speed by the accelerator pedal

- 1 Accelerate with accelerator pedal operation to the desired vehicle speed
- 2 Press the “-SET” switch

Changing the vehicle-to-vehicle distance (vehicle-to-vehicle distance control mode)

Pressing the switch changes the vehicle-to-vehicle distance as follows:

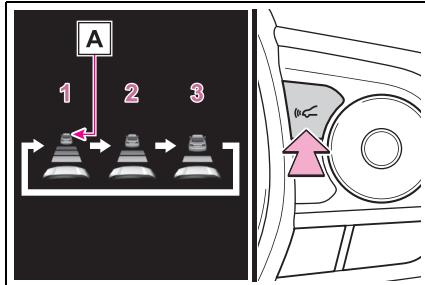

- 1 Long
- 2 Medium
- 3 Short

The vehicle-to-vehicle distance is set automatically to long mode when the power switch is turned to ON.

If a vehicle is running ahead of you, the preceding vehicle mark **A** will also be displayed.

Vehicle-to-vehicle distance settings (vehicle-to-vehicle distance control mode)

Select a distance from the table below. Note that the distances shown correspond to a vehicle speed of 80 km/h (50 mph). Vehicle-to-vehicle distance increases/decreases in accordance with vehicle speed. When the vehicle is stopped by system control, the vehicle stops at a certain vehicle-to-vehicle distance depending on the situation.

Distance options	Vehicle-to-vehicle distance
Long	Approximately 50 m (160 ft.)
Medium	Approximately 40 m (130 ft.)
Short	Approximately 30 m (100 ft.)

Resuming follow-up cruising when the vehicle has been stopped by system control (vehicle-to-vehicle distance control mode)

After the vehicle ahead of you starts off, press the “+RES” switch.

Your vehicle will also resume follow-up cruising if the accelerator pedal is depressed after the vehicle ahead of you starts off.

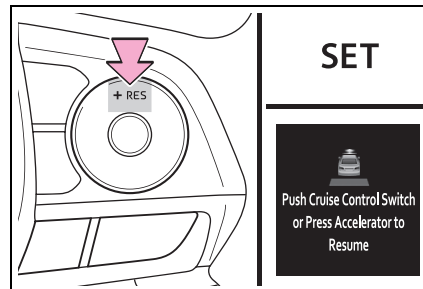

Canceling and resuming the speed control

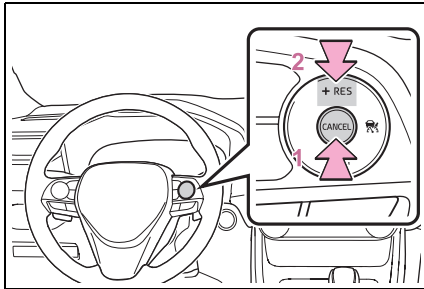

- 1 Pressing the cancel switch cancels the speed control.

The speed control is also canceled when the brake pedal is depressed. (When the vehicle has been stopped by system control, depressing the brake pedal does not cancel the setting.)

- 2 Pressing the “+RES” switch resumes the cruise control and returns vehicle speed to the set speed.

Approach warning (vehicle-to-vehicle distance control mode)

When your vehicle is too close to a vehicle ahead, and sufficient automatic deceleration via the cruise control is not possible, the display will flash and the buzzer will sound to alert the driver. An example of this would be if another driver cuts in front of you while you are following a vehicle. Depress the brake pedal to ensure an appropriate vehicle-to-vehicle distance.

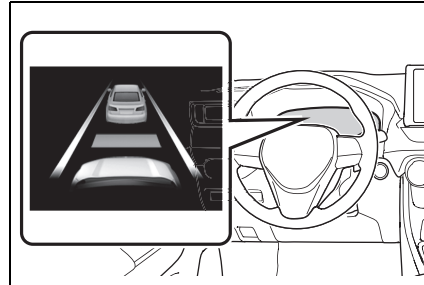

Warnings may not occur when

In the following instances, warnings may not occur even when the vehicle-to-vehicle distance is small.

- When the speed of the preceding vehicle matches or exceeds your vehicle speed
- When the preceding vehicle is traveling at an extremely slow speed
- Immediately after the cruise control speed was set
- When depressing the accelerator pedal

Selecting constant speed control mode

When constant speed control mode is selected, your vehicle will maintain a set speed without controlling the vehicle-to-vehicle distance. Select this mode only when vehicle-to-vehicle distance control mode does not function correctly due to a dirty radar, etc.

- 1 With the cruise control off, press and hold the cruise control main switch for 1.5 seconds or more.

Immediately after the switch is pressed, the dynamic radar cruise control indicator will come on. Afterwards, it switches to the cruise control indicator.

Switching to constant speed control mode is only possible when operating the switch with the cruise control off.

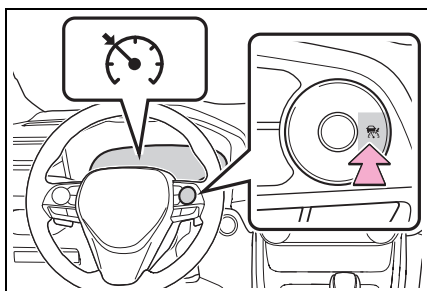

- 2 Accelerate or decelerate, with accelerator pedal operation, to the desired vehicle speed (at or above approximately 30 km/h [20 mph]) and press the “-SET” switch to set the speed.

Cruise control “SET” indicator will come on.

The vehicle speed at the moment the switch is released becomes the set speed.

Adjusting the speed setting: →P.342

Canceling and resuming the speed setting: →P.344

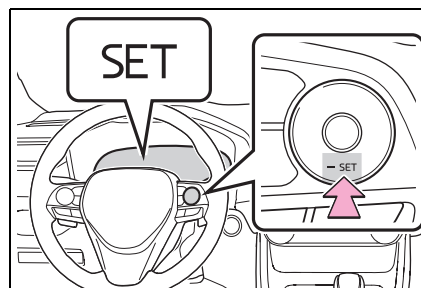

Dynamic Radar Cruise Control with Road Sign Assist

When this function is enabled and the system is operating in vehicle-to-vehicle distance control mode (→P.340), when a speed limit sign is detected, the recognized speed limit will be displayed with an up/down arrow. The set speed can be increased/reduced to the recognized speed limit by pressing and holding the “+RES”/“-SET” switch.

- When the current set speed is lower than the recognized speed limit

Press and hold the “+RES” switch.

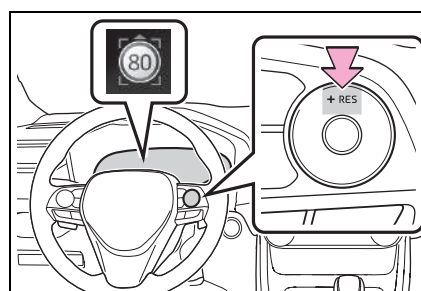

- When the current set speed is higher than the recognized speed limit

Press and hold the “-SET” switch.

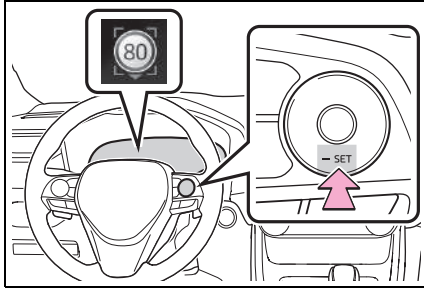

Enabling/Disabling the Dynamic Radar Cruise Control with Road Sign Assist

Dynamic Radar Cruise Control with Road Sign Assist can be

enabled/disabled in the  screen on the multi-information display. (→P.177)

Dynamic radar cruise control with full-speed range can be set when

- The shift lever is in D.
- The desired set speed can be set when the vehicle speed is approximately 30 km/h (20 mph) or more. (However, when the vehicle speed is set while driving at below approximately 30 km/h [20 mph], the set speed will be set to approximately 30 km/h [20 mph].)

Accelerating after setting the vehicle speed

The vehicle can accelerate by operating the accelerator pedal. After accelerating, the set speed resumes. However, during vehicle-to-vehicle distance control mode, the vehicle speed may decrease below the set speed in order to maintain the distance to the preceding vehicle.

When the vehicle stops while follow-up cruising

- Pressing the “+RES” switch while the vehicle ahead stops will resume follow-up cruising if the vehicle ahead starts off within approximately 3 seconds after the switch is pressed.
- If the vehicle ahead starts off within 3 seconds after your vehicle stops, follow-up cruising will be resumed.

Automatic cancelation of vehicle-to-vehicle distance control mode

Vehicle-to-vehicle distance control mode is automatically canceled in the following situations.

- VSC is activated.
- TRC is activated for a period of time.
- When the VSC or TRC system is turned off.
- The sensor cannot detect correctly because it is covered in some way.
- Pre-collision braking is activated.
- The parking brake is operated.
- The vehicle is stopped by system control on a steep incline.
- The following are detected when the vehicle has been stopped by system control:
 - The driver is not wearing a seat belt.
 - The driver’s door is opened.
 - The vehicle has been stopped for about 3 minutes

If vehicle-to-vehicle distance control mode is automatically canceled for any reasons other than the above, there may be a malfunction in the system.

Contact a SUZUKI dealer or a qualified workshop.

Automatic cancelation of constant speed control mode

Constant speed control mode is automatically canceled in the following situations:

- Actual vehicle speed is more than approximately 16 km/h (10 mph)

below the set vehicle speed.

- Actual vehicle speed falls below approximately 30 km/h (20 mph).
- VSC is activated.
- TRC is activated for a period of time.
- When the VSC or TRC system is turned off.
- Pre-collision braking is activated.
- The parking brake is operated.

If constant speed control mode is automatically canceled for any reasons other than the above, there may be a malfunction in the system. Contact a SUZUKI dealer or a qualified workshop.

■ **The Dynamic Radar Cruise Control with Road Sign Assist may not operate properly when**

As the Dynamic Radar Cruise Control with Road Sign Assist may not operate properly in conditions in which RSA may not operate or detect correctly (→P.336), when using this function, make sure to check the speed limit sign displayed.

In the following situations, the set speed may not be changed to the recognized speed limit by pressing and holding the “+RES”/“-SET” switch.

- If speed limit information is not available
- When the recognized speed limit is the same as the set speed
- When the recognized speed limit is outside of the speed range that the dynamic radar cruise control system can operate

■ **Brake operation**

A brake operation sound may be heard and the brake pedal response may change, but these are not malfunctions.

■ **Warning messages and buzzers for dynamic radar cruise control with full-speed range**

Warning messages and buzzers are used to indicate a system malfunction or

to inform the driver of the need for caution while driving. If a warning message is shown on the multi-information display, read the message and follow the instructions. (→P.315, 518)

■ **When the sensor may not be correctly detecting the vehicle ahead**

In the case of the following and depending on the conditions, operate the brake pedal when deceleration of the system is insufficient or operate the accelerator pedal when acceleration is required.

As the sensor may not be able to correctly detect these types of vehicles, the approach warning (→P.344) may not be activated.

- Vehicles that cut in suddenly
- Vehicles traveling at low speeds
- Vehicles that are not moving in the same lane
- Vehicles with small rear ends (trailers with no load on board, etc.)

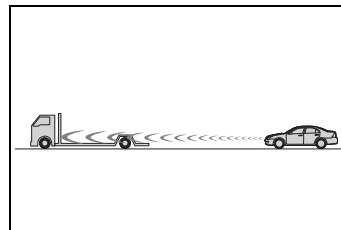

- Motorcycles traveling in the same lane
- When water or snow thrown up by the surrounding vehicles hinders the detecting of the sensor
- When your vehicle is pointing upwards (caused by a heavy load in the luggage compartment, etc.)

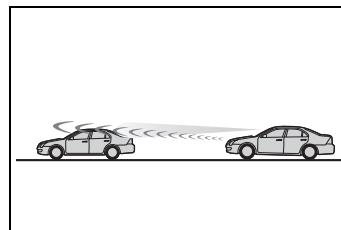

- Preceding vehicle has an extremely

high ground clearance

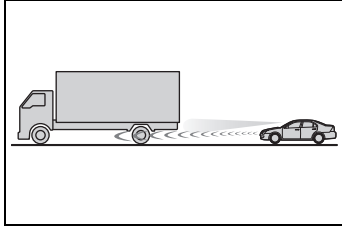

accelerates by depressing the accelerator pedal

■ **Conditions under which the vehicle-to-vehicle distance control mode may not function correctly**

In the case of the following conditions, operate the brake pedal (or accelerator pedal, depending on the situation) as necessary.

As the sensor may not be able to correctly detect vehicles ahead, the system may not operate properly.

- When the road curves or when the lanes are narrow

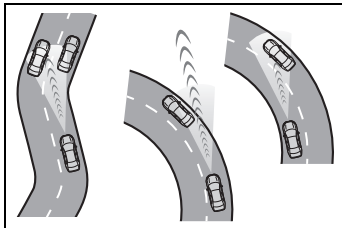

- When steering wheel operation or your position in the lane is unstable

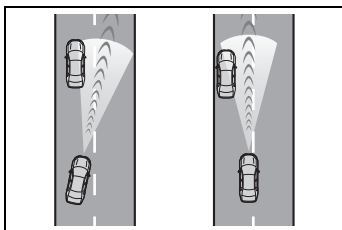

- When the vehicle ahead of you decelerates suddenly
- When driving on a road surrounded by a structure, such as in a tunnel or on a bridge
- While the vehicle speed is decreasing to the set speed after the vehicle

BSM (Blind Spot Monitor)

The Blind Spot Monitor is a system that has 2 functions:

- The BSM (Blind Spot Monitor) function

Assists the driver in making a decision when changing lanes

- The RCTA (Rear Crossing Traffic Alert) function

Assists the driver when backing up

These functions use the same sensors.

⚠ WARNING

■ **Cautions regarding the use of the BSM function**

The driver is solely responsible for safe driving. Always drive safely, taking care to observe your surroundings.

The BSM function is a supplementary function which alerts the driver that a vehicle is in a blind spot of the outside rear view mirrors or is approaching rapidly from behind into a blind spot. Do not overly rely on the BSM function. As the function cannot judge if it is safe to change lanes, over reliance could lead to an accident resulting in death or serious injury.

As the system may not function correctly under certain conditions, the driver's own visual confirmation of safety is necessary.

■ **Cautions regarding the use of the RCTA function**

The driver is solely responsible for safe driving. Always drive safely, taking care to observe your surroundings.

The RCTA function is only a supplementary function which alerts the driver that a vehicle is approaching from the right or left at the rear of the vehicle. As the RCTA function may not function correctly under certain conditions, the driver's own visual confirmation of safety is necessary.

Over reliance on this function may lead to an accident resulting death or serious injury.

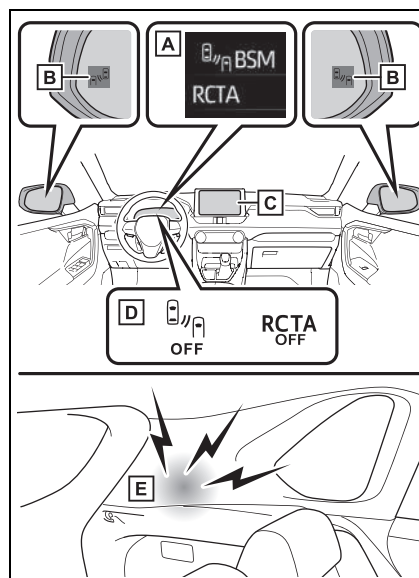
System components

A Multi-information display

Turning the BSM function/RCTA function on/off.

B Outside rear view mirror indicators

BSM function:

When a vehicle is detected in a blind spot of the outside rear view mirrors or approaching rapidly from behind into a blind spot, the outside rear view mirror indicator on the detected side will illuminate. If the turn signal lever is operated toward the detected side, the outside rear view mirror indicator will flash.

RCTA function:

When a vehicle approaching from the right or left at the rear of the vehicle is detected, both outside rear view mirror indicators will flash.

C Monitor screen display (RCTA function only)

If a vehicle approaching from the right or left at the rear of the vehicle is detected, the RCTA icon (→P.366) for the detected side will be displayed.

D BSM OFF indicator/RCTA OFF indicator

When the Blind Spot Monitor is disabled, the BSM OFF indicator illuminates.

When the RCTA function is disabled, the RCTA OFF indicator illuminates.

E RCTA buzzer (RCTA function only)

If a vehicle approaching from the right or left at the rear of the vehicle is detected, a buzzer will sound from behind the rear seat.

Turning the BSM function/RCTA function on/off

The BSM function and the RCTA function can be enabled/disabled on the  screen of the multi-infor-

mation display. (→P.177)

The BSM function/RCTA function will be enabled each time the power switch is turned to ON.

■ **Outside rear view mirror indicators visibility**

In strong sunlight, the outside rear view mirror indicator may be difficult to see.

■ **Hearing the RCTA buzzer**

The RCTA buzzer may be difficult to hear over loud noises such as high audio volume.

■ **When “Blind Spot Monitor Unavailable” or “RCTA Unavailable” is shown on the multi-information display**

The sensor voltage has become abnormal, or water, snow, mud, etc., may be built up in the vicinity of the sensor area of the rear bumper. (→P.363) Removing the water, snow, mud, etc., from the vicinity of the sensor area should return it to normal.

Also, the sensor may not function normally when used in extremely hot or cold weather.

■ **When “Blind Spot Monitor Malfunction Visit Your Dealer” or “RCTA Malfunction Visit Your Dealer” is shown on the multi-information display**

There may be a sensor malfunction or misaligned. Have the vehicle inspected at a SUZUKI dealer or a qualified workshop.

■ **Customization**

Some functions can be customized. (→P.177)

■ Certification for the Blind Spot Monitor

Manufacturer Postal Address ADC Automotive Distance Control Systems GmbH Peter-Dornier-Strasse 10, 88131 Lindau, Germany
ОПРОСТЕНА ЕС ДЕКЛАРАЦИЯ ЗА СЪОТВЕТСТВИЕ С настоящото ADC Automotive Distance Control Systems GmbH декларира, че този тип радиосъоръжение SRR3-A е в съответствие с Директива 2014/53/ЕС. Цялостният текст на ЕС декларацията за съответствие може да се намери на следния интернет адрес: http://continental.automotive-approvals.com/ радиочестотната лента или ленти, в която или които работи радиосъоръжението: 24.05–24.25 GHz максималната радиочестотна мощност, излъчвана в радиочестотната лента или ленти, в която или които работи радиосъоръжението: 100mW (20 dBm) Peak EIRP
DECLARACIÓN UE DE CONFORMIDAD SIMPLIFICADA Por la presente, ADC Automotive Distance Control Systems GmbH declara que el tipo de equipo radioeléctrico SRR3-A es conforme con la Directiva 2014/53/UE. El texto completo de la declaración UE de conformidad está disponible en la dirección Internet siguiente: http://continental.automotive-approvals.com/ Banda o bandas de frecuencia en las que opera el equipo radioeléctrico: 24.05–24.25 GHz Potencia máxima de radiofrecuencia transmitida en la banda o bandas de frecuencia en las que opera el equipo radioeléctrico: 100mW (20 dBm) Peak EIRP

ZJEDNODUŠENÉ EU PROHLÁŠENÍ O SHODĚ

Tímto ADC Automotive Distance Control Systems GmbH prohlašuje, že typ rádio-vého zařízení SRR3-A je v souladu se směrnicí 2014/53/EU. Úplné znění EU prohlášení o shodě je k dispozici na této internetové adrese:

<http://continental.automotive-approvals.com/>

Kmitočtové pásmo (kmitočtová pásma), v němž (v nichž) rádiové zařízení pracuje: 24.05–24.25 GHz

Maximální radiofrekvenční výkon vysílaný v kmitočtovém pásmu (v kmitočtových pásmech), v němž (v nichž) je rádiové zařízení provozováno: 100mW (20 dBm) Peak EIRP

FORENKLET EU-OVERENSSTEMMELSESESKLÆRING

Hermed erklærer ADC Automotive Distance Control Systems GmbH, at ra-dioudstyrstypen SRR3-A er i overensstemmelse med direktiv 2014/53/EU. EU-overensstemmelseserklæringens fulde tekst kan findes på følgende internetadresse:

<http://continental.automotive-approvals.com/>

Frekvensbånd, som radioudstyret fungerer på: 24.05–24.25 GHz

Maksimal radiofrekvenseffekt, der udsendes i de frekvensbånd, som radioudstyret fungerer på: 100mW (20 dBm) Peak EIRP

VEREINFACHTE EU-KONFORMITÄTSEKTLÄRUNG

Hiermit erklärt ADC Automotive Distance Control Systems GmbH, dass der Funkanlagentyp SRR3-A der Richtlinie 2014/53/EU entspricht. Der vollständige Text der EU-Konformitätserklärung ist unter der folgenden Internetadresse verfügbar:

<http://continental.automotive-approvals.com/>

Das Frequenzband oder die Frequenzbänder, in dem bzw. denen die Funkanlage betrieben wird: 24.05–24.25 GHz

Die in dem Frequenzband oder den Frequenzbändern, in dem bzw. denen die Funkanlage betrieben wird, abgestrahlte maximale Sendeleistung: 100mW (20 dBm) Peak EIRP

LIHTSUSTATUD ELI VASTAVUSDEKLARATSIOON

Käesolevaga deklareerib ADC Automotive Distance Control Systems GmbH, et käesolev raadioseadme tüüp SRR3-A vastab direktiivi 2014/53/EL nõuetele. ELi vastavusdeklaratsiooni täielik tekst on kättesaadav järgmisel internetiaadressil:

<http://continental.automotive-approvals.com/>

Sagedusriba(d), millel raadioseade töötab: 24.05–24.25 GHz

Raadioseadme töösagedus(t)el edastatav maksimaalne saatevõimsus: 100mW (20 dBm) Peak EIRP

ΑΠΛΟΥΣΤΕΥΜΕΝΗ ΔΗΛΩΣΗ ΣΥΜΜΟΡΦΩΣΗΣ ΕΕ

Με την παρούσα ο/η ADC Automotive Distance Control Systems GmbH, δηλώνει ότι ο ραδιοεξοπλισμός SRR3-A πληροί την οδηγία 2014/53/ΕΕ. Το πλήρες κείμενο της δήλωσης συμμόρφωσης ΕΕ διατίθεται στην ακόλουθη ιστοσελίδα στο διαδίκτυο:
<http://continental.automotive-approvals.com/>

Οι ζώνες συχνοτήτων στις οποίες λειτουργεί ο ραδιοεξοπλισμός: 24.05–24.25 GHz

η μέγιστη ραδιοηλεκτρική ισχύς στις ζώνες συχνοτήτων στις οποίες λειτουργεί ο ραδιοεξοπλισμός: 100mW (20 dBm) Peak EIRP

SIMPLIFIED EU DECLARATION OF CONFORMITY

Hereby, ADC Automotive Distance Control Systems GmbH declares that the radio equipment type SRR3-A is in compliance with Directive 2014/53/EU. The full text of the EU declaration of conformity is available at the following internet address:
<http://continental.automotive-approvals.com/>

Frequency band(s) in which the radio equipment operates: 24.05–24.25 GHz

Maximum radio-frequency power transmitted in the frequency band(s) in which the radio equipment operates: 100mW (20 dBm) Peak EIRP

DECLARATION UE DE CONFORMITE SIMPLIFIEE

Le soussigné, ADC Automotive Distance Control Systems GmbH, déclare que l'équipement radioélectrique du type SRR3-A est conforme à la directive 2014/53/UE. Le texte complet de la déclaration UE de conformité est disponible à l'adresse internet suivante:

<http://continental.automotive-approvals.com/>

Bandes de fréquences utilisées par l'équipement radioélectrique: 24.05–24.25 GHz

Puissance de radiofréquence maximale transmise sur les bandes de fréquences utilisées par l'équipement radioélectrique: 100mW (20 dBm)
Peak EIRP

POJEDNOSTAVLJENA EU IZJAVA O SUKLADNOSTI

ADC Automotive Distance Control Systems GmbH ovime izjavljuje da je radijska oprema tipa SRR3-A u skladu s Direktivom 2014/53/EU. Cjeloviti tekst EU izjave o sukladnosti dostupan je na sljedećoj internetskoj adresi::

<http://continental.automotive-approvals.com/>

Frekvencijski pojas (frekvencijski pojasi) u kojem (kojima) radijska oprema radi: 24.05–24.25 GHz

Najveća radiofrekvencijska snaga koja se prenosi u frekvencijskom pojasu (frekvencijskim pojasi) u kojem (kojima) radijska oprema radi: 100mW (20 dBm) Peak EIRP

DICHIARAZIONE DI CONFORMITÀ UE SEMPLIFICATA

Il fabbricante, ADC Automotive Distance Control Systems GmbH, dichiara che il tipo di apparecchiatura radio SRR3-A è conforme alla direttiva 2014/53/UE. Il testo completo della dichiarazione di conformità UE è disponibile al seguente indirizzo Internet:
<http://continental.automotive-approvals.com/>

Bande di frequenza di funzionamento dell'apparecchiatura radio: 24.05–24.25 GHz

Massima potenza a radiofrequenza trasmessa nelle bande di frequenza in cui opera l'apparecchiatura radio: 100mW (20 dBm) Peak EIRP

VIENKĀRŠŌTA ES ATBILSTĪBAS DEKLARĀCIJA

Ar šo ADC Automotive Distance Control Systems GmbH deklarē, ka radioiekārta SRR3-A atbilst Direktīvai 2014/53/ES. Pilns ES atbilstības deklarācijas teksts ir pieejams šādā interneta vietnē:
<http://continental.automotive-approvals.com/>

Frekvenču joslu(-as), kurā(-ās) radioiekārta darbojas: 24.05–24.25 GHz

Frekvenču joslā(-ās), kurā(-ās) darbojas radioiekārta, maksimālo pārraidītā signāla jaudu.: 100mW (20 dBm) Peak EIRP

SUPAPRASTINTA ES ATITIKTIES DEKLARACIJA

Aš, ADC Automotive Distance Control Systems GmbH, patvirtinu, kad radijo įrenginių tipas SRR3-A atitinka Direktyvą 2014/53/ES. Visas ES atitikties deklaracijos tekstas prieinamas šiuo interneto adresu:
<http://continental.automotive-approvals.com/>

Dažnių juosta (-os), kurioje (-iose) veikia radijo įrenginiai: 24.05–24.25 GHz

Didžiausia radijo dažnių galia, perduodama toje (tose) dažnių juostoje (-ose), kurioje (-iose) veikia radijo įrenginiai: 100mW (20 dBm) Peak EIRP

EGYSZERŪSÍTETT EU-MEGFELELŐSÉGI NYILATKOZAT

ADC Automotive Distance Control Systems GmbH igazolja, hogy a SRR3-A típusú rádióberendezés megfelel a 2014/53/EU irányelvnek. Az EU-megfelelőségi nyilatkozat teljes szövege elérhető a következő internetes címen::
<http://continental.automotive-approvals.com/>

Az(ok) a frekvenciasáv(ok), amely(ek)en a rádióberendezés működik:
24.05–24.25 GHz

Az abban a frekvenciasávban vagy azokban a frekvenciasávokban továbbított maximális jelerősség, amely(ek)ben a rádióberendezés üzemel:
100mW (20 dBm) Peak EIRP

DIKJARAZZJONI SSIMPLIFIKATA TA' KONFORMITÀ TAL-UE

B'dan, ADC Automotive Distance Control Systems GmbH, niddikjara li dan it-tip ta' tagħmir tar-radju SRR3-A huwa konformi mad-Direttiva 2014/53/UE. It-test kollu tad-dikjarazzjoni ta' konformità tal-UE huwa disponibbli f'dan l-indirizz tal-Internet li ġej:
<http://continental.automotive-approvals.com/>

Il-medda/meded tal-frekwenza li jaħdem fihom it-tagħmir tar-radju: 24.05–24.25 GHz

Il-potenza massima tal-frekwenza tar-radju trażmessa fil-medda/meded tal-frekwenza li jaħdem fihom it-tagħmir tar- radju: 100mW (20 dBm) Peak EIRP

VEREENVOUDIGDE EU-CONFORMITEITSVERKLARING

Hierbij verklaar ik, ADC Automotive Distance Control Systems GmbH, dat het type radioapparatuur SRR3-A conform is met Richtlijn 2014/53/EU. De volledige tekst van de EU-conformiteitsverklaring kan worden geraadpleegd op het volgende internetadres:
<http://continental.automotive-approvals.com/>

Frequentieband(en) waarin de radioapparatuur functioneert: 24.05–24.25 GHz

Maximaal radiofrequent vermogen uitgezonden in de frequentieband(en) waarin de radioapparatuur functioneert: 100mW (20 dBm) Peak EIRP

UPROSZCZONA DEKLARACJA ZGODNOŚCI UE

ADC Automotive Distance Control Systems GmbH niniejszym oświadcza, że typ urządzenia radiowego SRR3-A jest zgodny z dyrektywą 2014/53/UE. Pełny tekst deklaracji zgodności UE jest dostępny pod następującym adresem internetowym:

<http://continental.automotive-approvals.com/>

Zakresu(-ów) częstotliwości, w którym (których) pracuje urządzenie radiowe: 24.05–24.25 GHz

Maksymalnej mocy częstotliwości radiowej emitowanej w zakresie(-ach) częstotliwości, w którym (których) pracuje urządzenie radiowe: 100mW (20 dBm) Peak EIRP

DECLARAÇÃO UE DE CONFORMIDADE SIMPLIFICADA

O(a) abaixo assinado(a) ADC Automotive Distance Control Systems GmbH declara que o presente tipo de equipamento de rádio SRR3-A está em conformidade com a Diretiva 2014/53/UE. O texto integral da declaração de conformidade está disponível no seguinte endereço de Internet:

<http://continental.automotive-approvals.com/>

A(s) banda(s) de frequências em que o equipamento de rádio funciona: 24.05–24.25 GHz

A potência máxima de radiofrequências transmitida na(s) banda(s) de frequências em que o equipamento de rádio funciona: 100mW (20 dBm) Peak EIRP

DECLARAȚIA UE DE CONFORMITATE SIMPLIFICATĂ

Prin prezenta, ADC Automotive Distance Control Systems GmbH declară că tipul de echipamente radio SRR3-A este în conformitate cu Directiva 2014/53/UE. Textul integral al declarației UE de conformitate este disponibil la următoarea adresă în-ternet:

<http://continental.automotive-approvals.com/>

Banda (benzile) de frecvențe în care funcționează echipamentul radio:
24.05–24.25 GHz

Puterea maximă de radiofrecvență transmisă în banda (benzile) de frecvențe în care funcționează echipamentul radio: 100mW (20 dBm)
Peak EIRP

ZJEDNODUŠENÉ EÚ VYHLÁSENIE O ZHODE

ADC Automotive Distance Control Systems GmbH týmto vyhlasuje, že rádiové zariadenie typu SRR3-A je v súlade so smernicou 2014/53/EÚ. Úplné EÚ vyhlásenie o zhode je k dispozícii na tejto internetovej adrese:

<http://continental.automotive-approvals.com/>

Frekvenčné pásmo resp. pásma, v ktorých rádiové zariadenie pracuje:
24.05–24.25 GHz

Maximálny vysokofrekvenčný výkon prenášaný vo frekvenčnom pásme, resp. pásmach, v ktorých rádiové zariadenie pracuje: 100mW (20 dBm)
Peak EIRP

POENOSTAVLJENA IZJAVA EU O SKLADNOSTI

ADC Automotive Distance Control Systems GmbH potrjuje, da je tip radijske opreme SRR3-A skladen z Direktivo 2014/53/EU. Celotno besedilo izjave EU o skladnosti je na voljo na naslednjem spletnem naslovu:

<http://continental.automotive-approvals.com/>

Frekvenčni pas ali pasovi, na katerih deluje radijska oprema: 24.05–24.25 GHz

Največja energija za radijsko frekvenco, preneseno po frekvenčnem pasu ali pasovih, na katerih radijska oprema deluje: 100mW (20 dBm) Peak EIRP

YKSINKERTAISTETTU EU-VAATIMUSTENMUKAISUUSVAKUUTUS

ADC Automotive Distance Control Systems GmbH vakuuttaa, että radiolaitetyyppi SRR3-A on direktiivin 2014/53/EU mukainen. EU-vaatimustenmukaisuusvakuutuksen täysimittainen teksti on saatavilla seuraavassa internetosoitteessa:

<http://continental.automotive-approvals.com/>

Radiotaajuudet, joilla radiolaitte toimii: 24.05–24.25 GHz

Suurin mahdollinen lähetysteho radiotaajuuksilla, joilla radiolaitte toimii: 100mW (20 dBm) Peak EIRP

FÖRENKLAD EU-FÖRSÄKRAN OM ÖVERENSSTÄMMELSE

Härmed försäkrar ADC Automotive Distance Control Systems GmbH att denna typ av radioutrustning SRR3-A överensstämmer med direktiv 2014/53/EU. Den fullständiga texten till EU-försäkran om överensstämmelse finns på följande webbadress:

<http://continental.automotive-approvals.com/>

Det eller de frekvensband där radioutrustningen arbetar: 24.05–24.25 GHz

Den maximala radiofrekvensseffekt som överförs inom det eller de frekvensband där radioutrustningen arbetar: 100mW (20 dBm) Peak EIRP

EINFÖLDUÐ ESB SAMRÆMISYFIRLÝSING

Hér með lýsir ADC Automotive Distance Control Systems GmbH því yfir, að fjarskiptabúnaðurinn að gerð SRR3-A er í samræmi við tilskipun 2014/53/ ESB. Textinn í fullri lengd um Samræmisyfirlýsingu ESB er að gengilegur á eftirfarandi veffangi:

<http://continental.automotive-approvals.com/>

Bandbreidd(ir), sem fjarskiptabúnaðurinn starfar í: 24.05–24.25 GHz

Hámarks fjarskiptatíðni sendistyrkleika í bandbreiddinni/bandbreiddunum sem fjarskiptabúnaðurinn starfar í: 100mW (20 dBm) Peak EIRP

BASİTLEŞTİRİLMİŞ AB UYGUNLUK BEYANI

İşbu belge ile, ADC Automotive Distance Control Systems GmbH şirketi SRR3-A tipi radyo ekipmanının 2014/53/AB sayılı direktife uygun olduğunu beyan eder. AB uygunluk beyanının tam metni aşağıdaki İnternet adresinde mevcuttur:

<http://continental.automotive-approvals.com/>

Radyo cihazının çalıştığı frekans bandı/bantları: 24.05–24.25 GHz

Radyo ekipmanının çalıştığı frekans bandında/bantlarında iletilen maksimum radyo frekansı gücü: 100mW (20 dBm) Peak EIRP

⚠ WARNING**■ Handling the radar sensor**

Blind Spot Monitor sensors are installed inside the left and right sides of the rear bumper respectively. Observe the following to ensure the Blind Spot Monitor can function correctly.

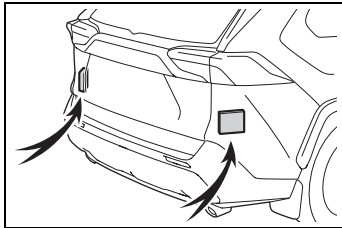

- Keep the sensors and the surrounding areas on the rear bumper clean at all times. If a sensor or its surrounding area on the rear bumper is dirty or covered with snow, the Blind Spot Monitor may not operate and a warning message (→P.350) will be displayed. In this situation, clear off the dirt or snow and drive the vehicle with the operation conditions of the BSM function (→P.365) satisfied for approximately 10 minutes. If the warning message does not disappear, have the vehicle inspected by a SUZUKI dealer or a qualified workshop.

- Do not subject a sensor or its surrounding area on the rear bumper to a strong impact.

If a sensor is moved even slightly off position, the system may malfunction and vehicles may not be detected correctly.

In the following situations, have your vehicle inspected by a SUZUKI dealer or a qualified workshop.

- A sensor or its surrounding area is subject to a strong impact.
- If the surrounding area of a sensor is scratched or dented, or part of them has become disconnected.
- Do not disassemble the sensor.
- Do not attach accessories, stickers (including transparent stickers), aluminum tape, etc. to a sensor or its surrounding area on the rear bumper.
- Do not modify the sensor or surrounding area on the rear bumper.
- If a sensor or the rear bumper needs to be removed/installed or replaced, contact a SUZUKI dealer or a qualified workshop.
- Do not paint the rear bumper any color other than an official Suzuki color.

The Blind Spot Monitor function**■ Vehicles that can be detected by the Blind Spot Monitor**

The BSM function uses radar sensors to detect the following vehicles traveling in adjacent lanes and advises the driver of the presence of such vehicles via the indicators on the outside rear view mirrors.

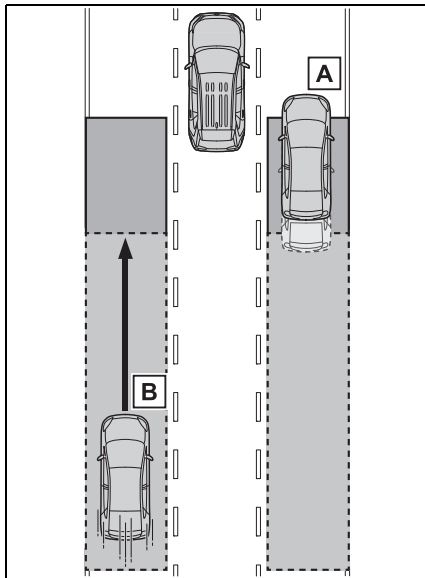

- A** Vehicles that are traveling in areas that are not visible using the outside rear view mirrors (the blind spots)
- B** Vehicles that are approaching rapidly from behind in areas that are not visible using the outside rear view mirrors (the blind spots)

■ **The BSM function detection areas**

The areas that vehicles can be detected in are outlined below.

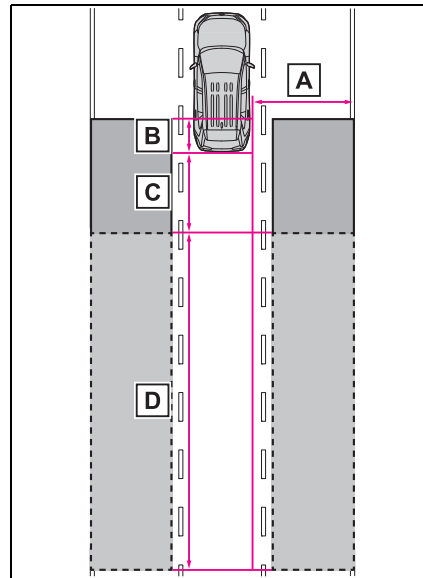

The range of each detection area is:

- A** Approximately 0.5 m (1.6 ft.) to 3.5 m (11.5 ft.) from either side of the vehicle
- B** Approximately 1 m (3.3 ft.) forward of the rear bumper
- C** Approximately 3 m (9.8 ft.) from the rear bumper
- D** Approximately 3 m (9.8 ft.) to 60 m (197 ft.) from the rear bumper

The greater the difference in speed between your vehicle and the detected vehicle is, the farther away the vehicle will be detected, causing the outside rear view mirror indicator to illuminate or flash.

■ The BSM function is operational when

The BSM function is operational when all of the following conditions are met:

- The BSM function is on.
- The shift lever is in a position other than R.
- The vehicle speed is greater than approximately 16 km/h (10 mph).

■ The BSM function will detect a vehicle when

The BSM function will detect a vehicle present in the detection area in the following situations:

- A vehicle in an adjacent lane overtakes your vehicle.
- You overtake a vehicle in an adjacent lane slowly.
- Another vehicle enters the detection area when it changes lanes.

■ Conditions under which the BSM function will not detect a vehicle

The BSM function is not designed to detect the following types of vehicles and/or objects:

- Small motorcycles, bicycles, pedestrians, etc.*
- Vehicles traveling in the opposite direction
- Guardrails, walls, signs, parked vehicles and similar stationary objects*
- Following vehicles that are in the same lane*
- Vehicles traveling 2 lanes away from your vehicle*
- Vehicles which are being overtaken rapidly by your vehicle

*: Depending on the conditions, detection of a vehicle and/or object may occur.

■ Conditions under which the BSM function may not function correctly

- The BSM function may not detect vehicles correctly in the following situations:
 - When the sensor is misaligned due to a strong impact to the sensor or its surrounding area
 - When mud, snow, ice, a sticker, etc. is covering the sensor or surrounding area on the rear bumper
 - When driving on a road surface that is wet with standing water during bad weather, such as heavy rain, snow, or fog
 - When multiple vehicles are approaching with only a small gap between each vehicle
 - When the distance between your vehicle and a following vehicle is short
 - When there is a significant difference in speed between your vehicle and the vehicle that enters the detection area
 - When the difference in speed between your vehicle and another vehicle is changing
 - When a vehicle enters a detection area traveling at about the same speed as your vehicle
 - As your vehicle starts from a stop, a vehicle remains in the detection area
 - When driving up and down consecutive steep inclines, such as hills, dips in the road, etc.
 - When driving on roads with sharp bends, consecutive curves, or uneven surfaces
 - When vehicle lanes are wide, or when driving on the edge of a lane, and the vehicle in an adjacent lane is far away from your vehicle
 - When an accessory (such as a bicycle carrier) is installed to the rear of the vehicle
 - When there is a significant difference in height between your vehicle and the vehicle that enters the detection area
 - Immediately after the BSM function/RCTA function are turned on
 - When towing a trailer

- Instances of the BSM function unnecessarily detecting a vehicle and/or object may increase in the following situations:
 - When the sensor is misaligned due to a strong impact to the sensor or its surrounding area
 - When the distance between your vehicle and a guardrail, wall, etc. that enters the detection area is short
 - When driving up and down consecutive steep inclines, such as hills, dips in the road, etc.
 - When vehicle lanes are narrow, or when driving on the edge of a lane, and a vehicle traveling in a lane other than the adjacent lanes enters the detection area
 - When driving on roads with sharp bends, consecutive curves, or uneven surfaces
 - When the tires are slipping or spinning
 - When the distance between your vehicle and a following vehicle is short
 - When an accessory (such as a bicycle carrier) is installed to the rear of the vehicle
 - When the vehicle throws up water or snow behind.

The Rear Crossing Traffic Alert function

■ Operation of the RCTA function

The RCTA function uses radar sensors to detect vehicles approaching from the right or left at the rear of the vehicle and alerts the driver of the presence of such vehicles by flashing the outside rear view mirror indicators and sounding a buzzer.

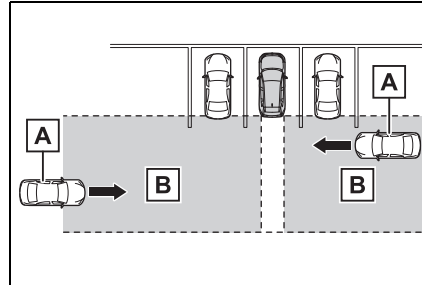

A Approaching vehicles

B Detection areas

■ RCTA icon display

When a vehicle approaching from the right or left at the rear of the vehicle is detected, the following will be displayed on the multimedia system screen.

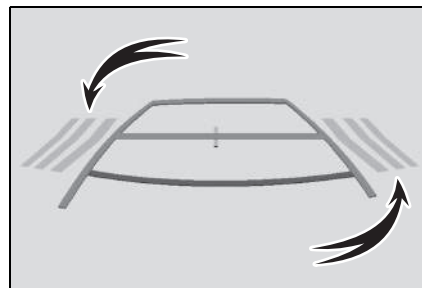

■ The RCTA function detection areas

The areas that vehicles can be detected in are outlined below.

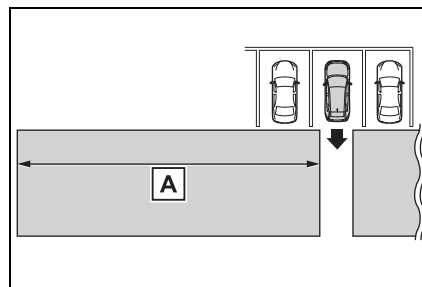

The buzzer can alert the driver of faster vehicles approaching from farther away.

Example:

Approaching vehicle	Speed	A Approximate alert distance
Fast	28 km/h (18 mph)	20 m (65 ft.)
Slow	8 km/h (5 mph)	5.5 m (18 ft.)

■ The RCTA function is operational when

The RCTA function operates when all of the following conditions are met:

- The RCTA function is on.
- The shift lever is in R.
- The vehicle speed is less than approximately 8 km/h (5 mph).
- The approaching vehicle speed is between approximately 8 km/h (5 mph) and 28 km/h (18 mph).

■ Setting the buzzer volume

The buzzer volume can be adjusted on the multi-information display. (→P.177)

■ Conditions under which the RCTA function will not detect a vehicle

The RCTA function is not designed to detect the following types of vehicles and/or objects.

- Vehicles approaching from directly behind
- Vehicles backing up in a parking space next to your vehicle
- Vehicles that the sensors cannot detect due to obstructions

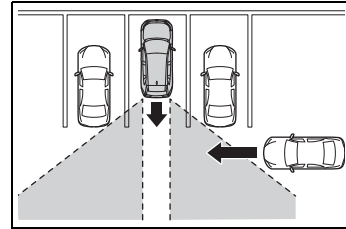

- Guardrails, walls, signs, parked vehicles and similar stationary objects*
- Small motorcycles, bicycles, pedestrians, etc.*
- Vehicles moving away from your vehicle
- Vehicles approaching from the parking spaces next to your vehicle*

*: Depending on conditions, detection of a vehicle and/or object may occur.

■ Conditions under which the RCTA function may not function correctly

- The RCTA function may not detect vehicles correctly in the following situations:
 - When the sensor is misaligned due to a strong impact to the sensor or its surrounding area
 - When mud, snow, ice, a sticker, etc. is covering the sensor or surrounding area on the rear bumper
 - When driving on a road surface that is wet with standing water during bad weather, such as heavy rain, snow, or fog
 - When multiple vehicles are approaching with only a small gap between each vehicle
 - When a vehicle is approaching at high speed
 - When parking on a steep incline, such as hills, a dip in the road, etc.
 - When an accessory (such as a bicycle carrier) is installed to the rear of the vehicle
 - When backing up on a slope with a sharp change in grade

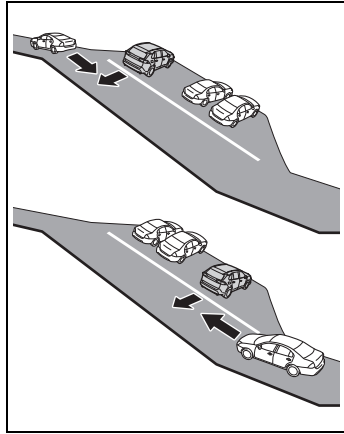

- When backing out of a shallow angle parking spot

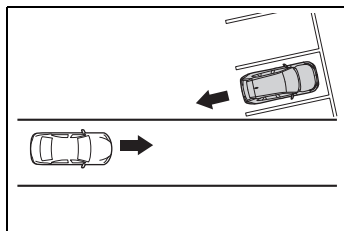

- Immediately after the RCTA function is turned on
- Immediately after the hybrid system is started with the RCTA function on
- When towing a trailer
- When the sensors cannot detect a vehicle due to obstructions

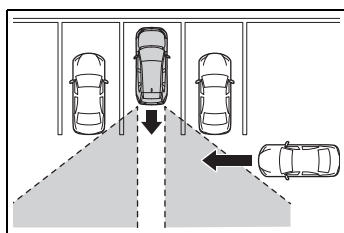

- Instances of the RCTA function unnecessarily detecting a vehicle and/or object may increase in the following situations:
 - When a vehicle passes by the side of your vehicle
 - When the parking space faces a street and vehicles are being driven on the

street

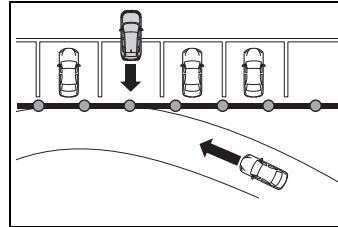

- When the distance between your vehicle and metal objects, such as a guardrail, wall, sign, or parked vehicle, which may reflect electrical waves toward the rear of the vehicle, is short
- When an accessory (such as a bicycle carrier) is installed to the rear of the vehicle

Parking assist-sensor

The distance from your vehicle to objects, such as a wall, when parallel parking or maneuvering into a garage is measured by the sensors and communicated via the multi-information display, multimedia system screen and a buzzer. Always check the surrounding area when using this system.

System components

■ Location and types of sensors

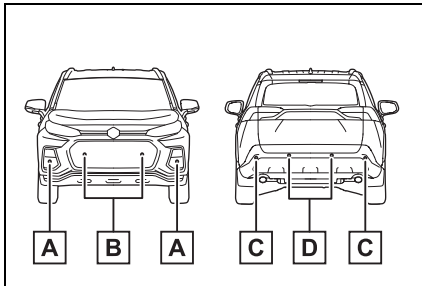

- A** Front corner sensors
- B** Front center sensors
- C** Rear corner sensors
- D** Rear center sensors

■ Display (Multi-information display)

When the sensors detect an object, such as a wall, a graphic is shown on the multi-information display depending on the position and distance to the object.

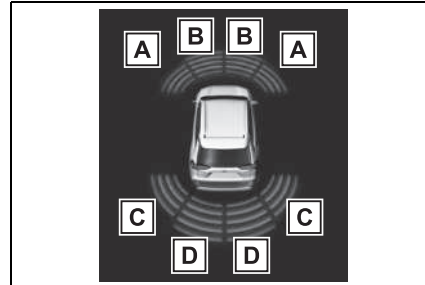

- A** Front corner sensor detection
- B** Front center sensor detection *¹
- C** Rear corner sensor detection *²
- D** Rear center sensor detection *²

*¹: Displayed when the shift lever is in a driving position

*²: Displayed when the shift lever is in R

■ Display (Audio system screen)

When the sensors detect an object, such as a wall, a graphic is shown on the multimedia system screen depending on the position and distance to the object.

A simplified image is displayed on the upper corner of the screen when an obstacle is detected.

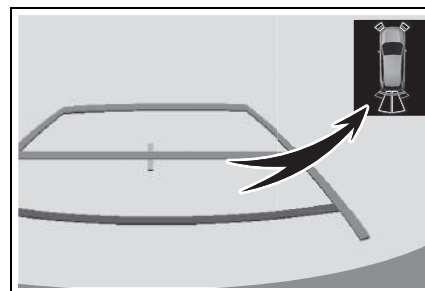

Turning parking assist-sensor on/off

The parking assist-sensor function can be enabled/disabled on the  screen of the multi-information display. (→P.177)

When the parking assist-sensor function is disabled, the parking assist-sensor OFF indicator (→P.163) illuminates on the multi-information display.

To re-enable the system, select  on the multi-information display, select

 and turn it on.

If the system is disabled, it will remain off even if the power switch is turned to ON after the power switch has been turned off.

WARNING

■ Parking assist-sensor precautions

Observe the following precautions. Failing to do so may result in the vehicle being unable to be driven safely and possibly cause an accident.

- Do not use the sensor at speeds in excess of 10 km/h (6 mph).
- The sensors' detection areas and reaction times are limited. When moving forward or reversing, check the areas surrounding the vehicle (especially the sides of the vehicle) for safety, and drive slowly, using the brake to control the vehicle's speed.
- Do not install accessories near the bumpers as those areas are within the sensors' detection areas.

- The area directly under the bumpers is not detected.
Thin posts or objects lower than the sensor may not be detected when approached, even if they have been detected once.

■ When to disable the function

In the following situations, disable the function as it may operate even though there is no possibility of a collision.

- The vehicle is equipped with a commercial fender pole, wireless antenna or fog lights.
- The front or rear bumper or a sensor receives a strong impact.
- A non-genuine Suzuki suspension (lowered suspension, etc.) is installed.
- Towing eyelets are installed.
- A backlit license plate is installed.
- When using an automatic car wash

■ When using the Parking assist-sensor

In the following situations, the system may not function correctly due to a sensor malfunction, etc. Have the vehicle checked by a SUZUKI dealer or a qualified workshop.

- The parking assist-sensor operation display flashes or shows continuously, and a beep sounds when no objects are detected.
- If the area around a sensor collides with something, or is subjected to strong impact.
- If the bumper or grille collides with something.
- If the display flashes or is displayed continuously and a buzzer does not sound, except when the mute function has been turned on.

**WARNING**

■ **Notes when washing the vehicle**

Do not apply intensive bursts of water or steam to the sensor area.

Doing so may result in the sensor malfunctioning.

- When using a high pressure washer to wash the vehicle, do not spray the sensors directly, as doing so may cause a sensor to malfunction.
- When using steam to clean the vehicle, do not direct steam too close to the sensors as doing so may cause a sensor to malfunction.

■ **The system can be operated when**

- The power switch is in ON.
- Parking assist-sensor function is on.
- The vehicle speed is less than about 10 km/h (6 mph).
- The shift lever is in other than P.

■ **If “Clean Parking Assist Sensor” is displayed on the multi-information display**

A sensor may be covered with ice, snow, dirt, etc. Remove the ice, snow, dirt, etc., from the sensor to return the system to normal.

Also, due to ice forming on a sensor at low temperatures, a warning message may be displayed or the sensor may not be able to detect an object. Once the ice melts, the system will return to normal.

If a warning message is displayed even if the sensor is clean, there may be a sensor malfunction. Have the vehicle inspected by a SUZUKI dealer or a qualified workshop.



■ **If “Parking Assist Unavailable” is displayed on the multi-information display**

Water may be continuously flowing over the sensor surface, such as in a heavy rain. When the system determines that it is normal, the system will return to normal.

■ **Sensor detection information**

- The sensor's detection areas are limited to the areas around the vehicle's front and rear bumpers.
- The following situations may occur during use.
 - Depending on the shape of the object and other factors, the detection distance may shorten, or detection may be impossible.
 - Detection may be impossible if static objects draw too close to the sensor.
 - There will be a short delay between static object detection and display (warning buzzer sounds). Even at low speeds, there is a possibility that the object will come within 25 cm (9.8 in.) before the display is shown and the warning buzzer sounds.
 - It might be difficult to hear the buzzer due to the volume of the audio system or air flow noise of the air conditioning system.
 - It may be difficult to hear the sound of this system due to the buzzers of other systems.

■ **Conditions under which the function may not function correctly**

Certain vehicle conditions and the surrounding environment may affect the ability of a sensor to correctly detect objects. Particular instances where this

may occur are listed below.

- There is dirt, snow or ice on a sensor. (Cleaning the sensors will resolve this problem.)
- A sensor is frozen. (Thawing the area will resolve this problem.)
In especially cold weather, if a sensor is frozen the sensor display may be displayed abnormally, or objects, such as a wall, may not be detected.
- A sensor is covered in any way.
- When a sensor or the area around a sensor is extremely hot or cold.
- On an extremely bumpy road, on an incline, on gravel, or on grass.
- The vicinity of the vehicle is noisy due to vehicle horns, motorcycle engines, air brakes of large vehicles, or other loud noises producing ultrasonic waves.
- There is another vehicle equipped with parking assist sensors in the vicinity.
- A sensor is coated with a sheet of spray or heavy rain.
- If a sensor is hit by a large amount of water, such as when driving on a flooded road.
- If the vehicle is significantly tilted.
- The vehicle is approaching a tall or curved curb.
- If objects draw too close to the sensor.

■ **Objects which may not be properly detected**

The shape of the object may prevent the sensor from detecting it. Pay particular attention to the following objects:

- Wires, fences, ropes, etc.
- Cotton, snow and other materials that absorb sound waves

- Sharply-angled objects
- Low objects
- Tall objects with upper sections projecting outwards in the direction of your vehicle

People may not be detected if they are wearing certain types of clothing.

Sensor detection display, object distance

■ **Detection range of the sensors**

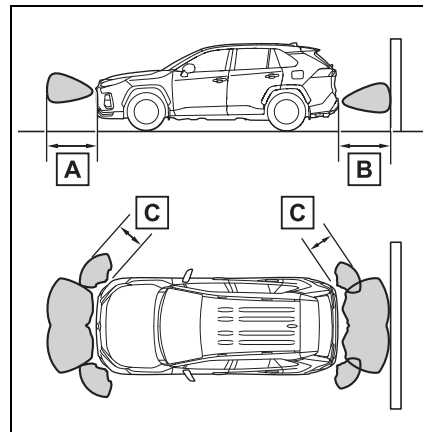

A Approximately 100 cm (3.3 ft.)

B Approximately 150 cm (4.9 ft.)

C Approximately 60 cm (2.0 ft.)

The diagram shows the detection range of the sensors. Note that the sensors cannot detect objects that are extremely close to the vehicle.



The range of the sensors may change depending on the shape of the object, etc.

■ **Distance display**



When an object is detected by a sensor, the approximate distance to the object will be displayed on the multi-information display or multimedia system screen. (As the distance to the object becomes short, the distance segments may blink.)

The images may differ from that shown in the illustrations.



- Approximate distance to object
 - Front center sensor: 100 cm (3.3 ft.) to 60 cm (2.0 ft.)
 - Rear center sensor: 150 cm (4.9 ft.) to 60 cm (2.0 ft.)

Multi-information display	Multimedia system screen
	



- Approximate distance to object: 60 cm (2.0 ft.) to 45 cm (1.5 ft.)

Multi-information display	Multimedia system screen
	

- Approximate distance to object: 45 cm (1.5 ft.) to 30 cm (1.0 ft.)



Multi-information display	Multimedia system screen
	

- Approximate distance to object: 30 cm (1.0 ft.) to 15 cm (0.5 ft.)

Multi-information display*	Multimedia system screen
	

*: The distance segments will blink slowly.

- Approximate distance to object: Less than 15 cm (0.5 ft.)

Multi-information display*	Multimedia system screen
	

*: The distance segments will blink rapidly.

■ **Buzzer operation and distance to an object**

A buzzer sounds when the sensors are operating.

- The buzzer beeps faster as the vehicle approaches an object. When the vehicle comes within approximately 30 cm (1.0 ft.) of the object, the buzzer sounds continuously
- When 2 or more sensors simultaneously detect a static object, the buzzer sounds for the nearest object.
- Even when the sensors are operating, the buzzer will be muted in some situations. (automatic buzzer mute function)

■ **Muting the buzzer sound**

- Automatic buzzer mute function
Even when the sensors are operating, the buzzer will be muted in the following situations:
 - The distance between the vehicle and the detected object does not become shorter (except when the distance between the vehicle and object is 30 cm [1.0 ft.] or less).
 - Your vehicle is moving away from the object.
 - There are no detectable objects enter-

ing the path of your vehicle. However, if another object is detected or the situation changes while the buzzer is muted, the buzzer begins sounding again.

- To mute the buzzer sound
The buzzer can be temporarily muted by pressing  of the meter control switches while a suggestion that says mute is available is shown on the multi-information display.

- When the mute is canceled
Mute will be automatically canceled in the following situations.
 - When the shift position is changed
 - When the vehicle speed has reached or exceeded a certain speed
 - When the parking assist is turned off once and turned on again
 - When the power switch is turned off once and turned to ON again

■ **Customization**

The buzzer volume can be adjusted on the multi-information display. (except for vehicles without front sensors) (→P.177)

PKSB (Parking Support Brake)

The Parking Support Brake system consists of the following functions that operate when driving at a low speed or backing up, such as when parking. When the system determines that the possibility of a collision with a detected object is high, a warning operates to urge the driver to take evasive action. If the system determines that the possibility of a collision with a detected object is extremely high, the brakes are automatically applied to help avoid the collision or help reduce the impact of the collision.

PKSB (Parking Support Brake) system

■ Parking Support Brake function (static objects)

→P.379

■ Parking Support Brake function (rear-crossing vehicles)

→P.384

WARNING

■ Limitations of the Parking Support Brake system

Do not overly rely on the system, as doing so may lead to an accident.

Always drive while checking the safety of the surroundings of the vehicle.

Depending on the vehicle and road conditions, weather, etc., the system may not operate.

The detection capabilities of sensors and radars are limited. Always drive while checking the safety of the surroundings of the vehicle.

- The driver is solely responsible for safe driving. Always drive carefully, taking care to observe your surroundings. The Parking Support Brake system is designed to provide support to lessen the severity of collisions. However, it may not operate in some situations.
- The Parking Support Brake system is not designed to stop the vehicle completely. Additionally, even if the system has stopped the vehicle, it is necessary to depress the brake pedal immediately as brake control will be canceled after approximately 2 seconds.
- Do not attempt to test the operation of the Parking Support Brake system yourself such as intentionally driving to a vehicle or wall. Depending on the situations, the system may not operate properly, possibly leading to an accident.



NOTICE

■ If “PKSB Unavailable” is displayed on the multi-information display and the PKSB OFF indicator illuminates

If this message is displayed immediately after the power switch is changed to ON, operate the vehicle carefully, paying attention to your surroundings. It may be necessary to drive the vehicle for a certain amount of time before the system returns to normal. (If the system does not return to normal after driving for a while, clean the sensors and their surrounding area on the bumpers.)

Enabling/Disabling the Parking Support Brake

The Parking Support Brake can be enabled/disabled on the  screen of the multi-information display. All of the Parking Support Brake functions (static objects and rear-crossing vehicles) are enabled/disabled simultaneously. (→P.177)

When the Parking Support Brake is disabled, the PKSB OFF indicator (→P.163) illuminates on the multi-information display.

To re-enable the system, select  on the multi-information display, select



and turn it on.

If the system is disabled, it will remain off even if the power switch is turned to ON after the power switch has been turned off.

Display and buzzer for hybrid system output restriction control and brake control

If the hybrid system output restriction control or brake control operates, a buzzer will sound and a message will be displayed on the multi-information display or multimedia system screen, to alert the driver.

Depending on the situation, hybrid system output restriction control will operate to either limit acceleration or restrict output as much as possible.

- Hybrid system output restriction control is operating (acceleration restriction)

Acceleration greater than a certain amount is restricted by the system.

Multi-information display: “Object Detected Acceleration Reduced”

Multimedia system screen: No warning displayed

PKSB OFF indicator: Not illuminated

Buzzer: Does not sound

- Hybrid system output restriction control is operating (output restricted as much as possible)

The system has determined that stronger-than-normal brake operation is necessary.

Multi-information display: “BRAKE!”

Multimedia system screen: “BRAKE!”

PKSB OFF indicator: Not illuminated

Buzzer: Short beep

- Brake control is operating

The system determined that emergency braking is necessary.

Multi-information display: "BRAKE!"

Multimedia system screen: "BRAKE!"

PKSB OFF indicator: Illuminated

Buzzer: Short beep

- Vehicle stopped by system operation

The vehicle has been stopped by brake control operation.

Multi-information display: "Switch to Brake" (If the accelerator pedal is not depressed, "Press Brake Pedal" will be displayed.)

Multimedia system screen: "Press Brake Pedal"

PKSB OFF indicator: Illuminated

Buzzer: Short beep

System overview

If the Parking Support Brake determines that a collision with a detected object is possible, the hybrid system output will be restricted to restrain any increase in the vehicle speed. (Hybrid system output restriction control: See figure 2.)

Additionally, if the accelerator pedal continues to be depressed, the brakes will be applied automatically to reduce the vehicle speed. (Brake control: See figure 3.)

- Figure 1: When the PKSB (Parking Support Brake) is not operating

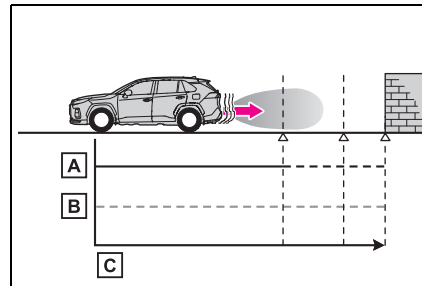

A Hybrid system output

B Braking force

C Time

- Figure 2: When hybrid system output restriction control operates

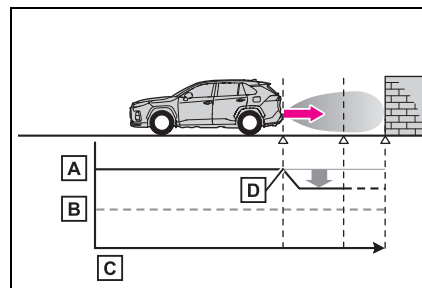

A Hybrid system output

B Braking force

C Time

D Hybrid system output restriction control begins operating (System determines that possibility of collision with detected object is high)

- Figure 3: When hybrid system output restriction control and brake control operates

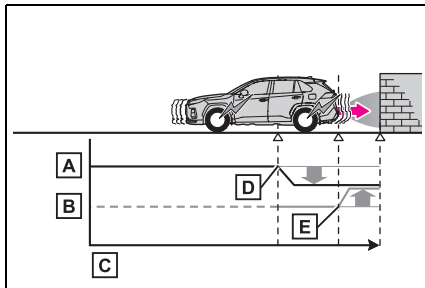

- A** Hybrid system output
- B** Braking force
- C** Time
- D** Hybrid system output restriction control begins operating (System determines that possibility of collision with detected object is high)
- E** Brake control begins operating (System determines that possibility of collision with detected object is extremely high)

■ **If the Parking Support Brake has operated**

If the vehicle is stopped due to operation of the Parking Support Brake, the Parking Support Brake will be disabled and the PKSB OFF indicator will illuminate. If the Parking Support Brake operates unnecessarily, brake control can be canceled by depressing the brake pedal or waiting for approximately 2 seconds for it to automatically be canceled. Then, the vehicle can be operated by depressing the accelerator pedal.

■ **Re-enabling the Parking Support Brake**

To re-enable the Parking Support Brake when it is disabled due to operation of the Parking Support Brake, either enable the system again (→P.376), or turn the power switch off and then back

to ON. Additionally, if the object becomes no longer in the traveling direction of the vehicle or if the traveling direction of the vehicle changes (such as changing from moving forward to backing up, or from backing up to moving forward), the system will be re-enabled automatically.

■ **If “Parking Support Brake Unavailable” is displayed on the multi-information display and the PKSB OFF indicator illuminates**

- If “Clean Parking Assist Sensor” is displayed simultaneously, a sensor may be covered with ice, snow, dirt, etc. In this case, remove the ice, snow, dirt, etc., from the sensor to return the system to normal. If this message is shown even after removing dirt from the sensor, or shown when the sensor was not dirty to begin with, have the vehicle inspected at a SUZUKI dealer or a qualified workshop.
- If “Parking Assist Unavailable” is displayed simultaneously, water may be continuously flowing over the sensor surface, such as in a heavy rain. When the system determines that it is normal, the system will return to normal.

Parking Support Brake function (static objects)

If the sensors detect a static object, such as a wall, in the traveling direction of the vehicle and the system determines that a collision may occur due to the vehicle suddenly moving forward due to an accidental accelerator pedal operation, the vehicle moving the unintended direction due to the wrong shift position being selected, or while parking or traveling at low speeds, the system will operate to lessen the impact with the detected static object and reduce the resulting damage.

Examples of function operation

This function will operate in situations such as the following if an object is detected in the traveling direction of the vehicle.

- When traveling at a low speed and the brake pedal is not depressed, or is depressed late

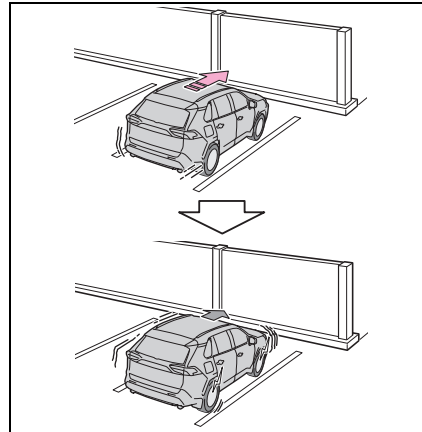

- When the accelerator pedal is depressed excessively

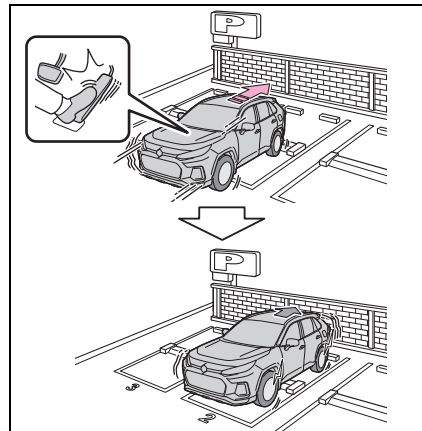

■ **When the vehicle moves in the unintended direction due to the wrong shift position being selected**

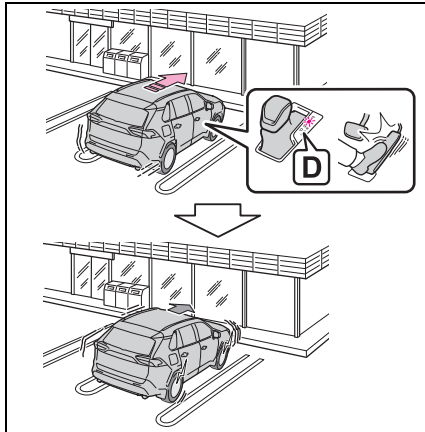

Types of sensors

→P.369

⚠ WARNING

■ **To ensure the Parking Support Brake can operate properly**

Observe the following precautions regarding the sensors (→P.369). Failure to do so may cause a sensor to not operate properly, and may cause an accident.

- Do not modify, disassemble or paint the sensors.
- Do not replace a sensor with a part other than a genuine part.
- Do not subject a sensor or its surrounding area to a strong impact.
- Do not damage the sensors, and always keep them clean.

- If the area around a radar sensor is subjected to an impact, the system may not operate properly due to a sensor malfunction. Have the vehicle inspected by a SUZUKI dealer or a qualified workshop.

■ **Handling the suspension**

Do not modify the suspension, as changes to the height or inclination of the vehicle may prevent the sensors from detecting objects correctly or cause the system to not operate or operate unnecessarily.

■ **If the Parking Support Brake function (static objects) operates unnecessarily, such as at a railroad crossing**

In the event that the Parking Support Brake function (static objects) operates unnecessarily, such as at a railroad crossing, brake control will be canceled after approximately 2 seconds, allowing you to proceed forward and leave the area, brake control can also be canceled by depressing the brake pedal. Depressing the accelerator pedal after brake control is canceled will allow you to proceed forward and leave the area.

■ **Notes when washing the vehicle**

Do not apply intensive bursts of water or steam to the sensor area.

Doing so may result in the sensor malfunctioning.

- When using a high pressure washer to wash the vehicle, do not spray the sensors directly, as doing so may cause a sensor to malfunction.
- When using steam to clean the vehicle, do not direct steam too close to the sensors as doing so may cause a sensor to malfunction.

**WARNING****■ When to disable the Parking Support Brake**

In the following situations, disable the Parking Support Brake as the system may operate even though there is no possibility of a collision.

- When inspecting the vehicle using a chassis roller, chassis dynamo or free roller
- When loading the vehicle onto a boat, truck or other transport vessel
- If the suspension has been modified or tires of a size other than specified are installed
- If the front of the vehicle is raised or lowered due to the carried load
- When equipment that may obstruct a sensor is installed, such as a towing eyelet, bumper protector (an additional trim strip, etc.), bicycle carrier, or snow plow
- When using an automatic car wash

■ The Parking Support Brake function (static object) will operate when

The function will operate when the PKSB OFF indicator is not illuminated (→P.162, 163) and all of the following conditions are met:

- Hybrid system output restriction control
 - The Parking Support Brake is enabled.
 - The vehicle speed is approximately 15 km/h (9 mph) or less.
 - There is a static object in the traveling direction of the vehicle and approximately 2 to 4 m (6 to 13 ft.) away.
 - The Parking Support Brake determines that a stronger-than-normal brake operation is necessary to avoid a collision.
- Brake control

- Hybrid system output restriction control is operating
- The Parking Support Brake determines that an immediate brake operation is necessary to avoid a collision.

■ The Parking Support Brake function (static objects) will stop operating when

The function will stop operating if any of the following conditions are met:

- Hybrid system output restriction control
 - The Parking Support Brake is disabled.
 - The system determines that the collision has become avoidable with normal brake operation.
 - The static object is no longer approximately 2 to 4 m (6 to 13 ft.) away from the vehicle or in the traveling direction of the vehicle.
- Brake control
 - The Parking Support Brake is disabled.
 - Approximately 2 seconds have elapsed since the vehicle was stopped by brake control.
 - The brake pedal is depressed after the vehicle is stopped by brake control.
 - The static object is no longer approximately 2 to 4 m (6 to 13 ft.) away from the vehicle or in the traveling direction of the vehicle.

■ Detection range of the Parking Support Brake function (static objects)

The detection range of the Parking Support Brake function (static objects) differs from the detection range of the parking assist-sensor. (→P.372) Therefore, even if the parking assist-sensor detects an object and provides a warning, the Parking Support Brake function (static objects) may not start operating.

■ Objects that the Parking Support Brake function (static objects) may not detect

The sensors may not be able to detect certain objects, such as the following:

- Pedestrian
- Cotton, snow, and other materials that are poor reflectors of sonic waves
- Objects which are not perpendicular to the ground, are not perpendicular to the traveling direction of the vehicle, are uneven or are waving
- Low objects
- Thin objects such as wires, fences, ropes and signposts
- Objects that are extremely close to the bumper
- Sharply-angled objects
- Tall objects with upper sections projecting outwards in the direction of your vehicle

■ **Situations in which the Parking Support Brake function (static objects) may not operate**

When the shift lever is in N

■ **Parking assist-sensor buzzer**

Regardless of whether the parking assist-sensor function is enabled or not (→P.370), if the Parking Support Brake function (static objects) is enabled (→P.376), the front or rear sensors detect an object and brake control and hybrid system output restriction control are performed, the parking assist-sensor buzzer will sound to notify the driver of the approximate distance to the object.

■ **Situations in which the Parking Support Brake function (static objects) may operate even if there is no possibility of a collision**

In some situations, such as the following, the Parking Support Brake function (static objects) may operate even though there is no possibility of a collision.

- Vehicle surroundings
 - When driving on a narrow road

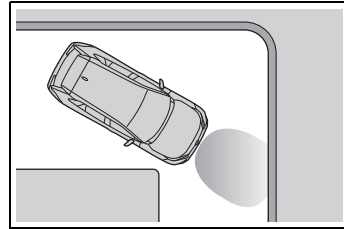

- When driving on a gravel road or in an area with tall grass

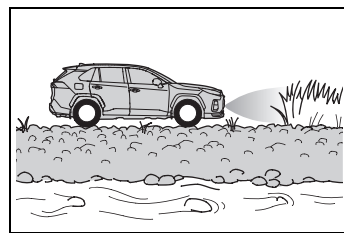

- When driving toward a banner, flag, low-hanging branch or boom barrier (such as those used at railroad crossings, toll gates and parking lots)
- When there is a structure on the roadside (such as when driving in a narrow tunnel, on a narrow bridge or on a narrow road)
- When parallel parking
- When there is a rut or hole in the surface of the road
- When driving on a metal cover (grating), such as those used for drainage ditches
- When driving up or down a steep slope
- If a sensor is hit by a large amount of water, such as when driving on a flooded road
- When loaded on ships or trucks
- Moving type automatic car wash
- Lift type parking area or multi-story parking lot
- Underground parking area
- Structures on the ground (speed bumps, cat's eyes, etc.)
- Differences in height
- When moving straight ahead or turning right
- Snow-melting pipes
- Devices for detecting vehicles, such as traffic lights, devices for detecting

traffic congestion, or devices for detecting empty spaces in parking areas

- Railroad tracks
- H-shaped steel
- When there are vehicles on both sides, or there is a vehicle that resembles this vehicle

● Weather

- If a sensor is covered with ice, snow, dirt, etc. (when cleared, the system will return to normal)
- If heavy rain or water strikes a sensor
- When driving in inclement weather such as fog, snow or a sandstorm
- Strong wind is blowing

● Other sonic wave sources

- When vehicle horns, vehicle detectors, motorcycle engines, air brakes of large vehicles, the clearance sonar of other vehicles or other devices which produce ultrasonic waves are near the vehicle
- If a sticker or an electronic component, such as a backlit license plate (especially fluorescent type), fog lights, fender pole or wireless antenna is installed near a sensor

● Changes in the vehicle posture

- If the vehicle is significantly tilted
- If the front of the vehicle is raised or lowered due to the carried load
- If the orientation of a sensor has been changed due to a collision or other impact

■ Situations in which the Parking Support Brake function (static objects) may not operate properly

In some situations, such as the following, this function may not operate properly.

● Weather

- When a sensor or the area around a sensor is extremely hot or cold

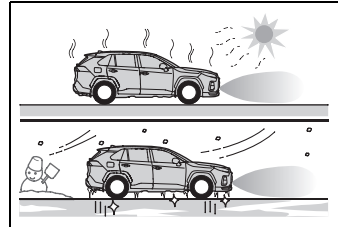

- When strong winds are blowing

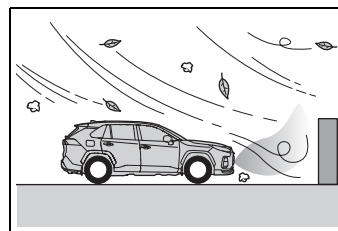

- If a sensor is covered with ice, snow, dirt, etc. (when cleared, the system will return to normal)
- If heavy rain or water strikes a sensor
- When driving in inclement weather such as fog, snow or a sandstorm
- A sensor is frozen. (Thawing the area will resolve this problem.)

● Vehicle surroundings

- When an object that cannot be detected is between the vehicle and a detected object
- If an object such as a vehicle, motorcycle, bicycle or pedestrian cuts in front of the vehicle or runs out from the side of the vehicle
- The vehicle is approaching a tall or curved curb.
- On an extremely bumpy road, on an incline, on gravel, or on grass.
- The objects draw too close to the sensor.

● Other sonic waves sources

- When vehicle horns, vehicle detectors, motorcycle engines, air brakes of large vehicles, the clearance sonar of other vehicles or other devices which produce ultrasonic waves are near the vehicle
- If a sticker or an electronic component, such as a backlit license plate (especially fluorescent type), fog

lights, fender pole or wireless antenna is installed near a sensor

- Changes in the vehicle
- If the vehicle is significantly tilted
- If the front of the vehicle is raised or lowered due to the carried load
- If the orientation of a sensor has been changed due to a collision or other impact
- When equipment that may obstruct a sensor is installed, such as a towing eyelet, bumper protector (an additional trim strip, etc.), bicycle carrier, or snow plow
- If the suspension has been modified or tires of a size other than specified are installed
- If paint or a sticker is applied to the sensor

Parking Support Brake function (rear-crossing vehicles)

If a rear radar sensor detects a vehicle approaching from the right or left at the rear of the vehicle and the system determines that the possibility of a collision is high, this function will perform brake control to reduce the likelihood of an impact with the approaching vehicle.

Examples of function operation

This function will operate in situations such as the following if a vehicle is detected in the traveling direction of the vehicle.

- When reversing, a vehicle is approaching and the brake pedal is not depressed, or is depressed late

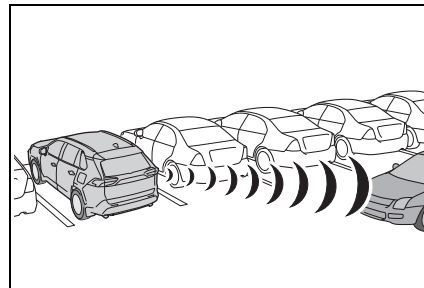

Types of sensors

→P.363

**WARNING****■ To ensure the Parking Support Brake (rear-crossing vehicles) can operate properly**

Observe the following precautions regarding the rear radar sensors (→P.363). Failure to do so may cause a sensor to not operate properly, and may cause an accident.

- Do not modify, disassemble or paint the sensors.
- Do not replace a rear radar sensor with a part other than a genuine part.
- Do not damage the rear radar sensors, and always keep the radar sensors and their surrounding area on the bumper clean.
- If the area around a rear radar sensor is subjected to an impact, the system may not operate properly due to a sensor malfunction. Have the vehicle inspected by a SUZUKI dealer or a qualified workshop.
- Observe the rear radar sensor handling precautions. (→P.363)

■ The Parking Support Brake function (rear-crossing vehicles) will operate when

The function will operate when the PKSB OFF indicator is not illuminated (→P.162, 163) and all of the following conditions are met:

- Hybrid system output restriction control
 - The Parking Support Brake is enabled.
 - The vehicle speed is approximately 15 km/h (9 mph) or less.
 - Vehicles are approaching from the right or left at the rear of the vehicle at a traveling speed of more than approximately 8 km/h (5 mph)
 - The shift lever is in R.
 - The Parking Support Brake deter-

mines that a stronger than normal brake operation is necessary to avoid a collision with an approaching vehicle.

- Brake control
 - Hybrid system output restriction control is operating
 - The Parking Support Brake determines that an emergency brake operation is necessary to avoid a collision with an approaching vehicle.

■ The Parking Support Brake function (rear-crossing vehicles) will stop operating when

The function will stop operating if any of the following conditions are met:

- Hybrid system output restriction control
 - The Parking Support Brake is disabled.
 - The collision becomes avoidable with normal brake operation.
 - A vehicle is no longer approaching from the right or left at the rear of the vehicle.
- Brake control
 - The Parking Support Brake is disabled.
 - Approximately 2 seconds have elapsed since the vehicle was stopped by brake control.
 - The brake pedal is depressed after the vehicle is stopped by brake control.
 - A vehicle is no longer approaching from the right or left at the rear of the vehicle.

■ Detection area of the Parking Support Brake function (rear-crossing vehicles)

The detection area of the Parking Support Brake function (rear-crossing vehicles) differs from the detection area of the RCTA function (→P.366). Therefore, even if the RCTA function detects a vehicle and provides an alert, the Parking Support Brake function (rear-crossing vehicles) may not start operating.

■ **Conditions under which the Parking Support Brake function (rear-crossing vehicles) will not detect a vehicle**

The Parking Support Brake function (rear-crossing vehicles) is not designed to detect the following types of vehicles and/or objects:

- Vehicles approaching from directly behind
- Vehicles backing up in a parking space next to your vehicle
- Vehicles that the sensors cannot detect due to obstructions

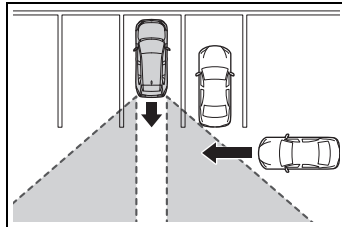

- Vehicles which suddenly accelerate or decelerate near your vehicle
- Guardrails, walls, signs, parked vehicles and similar stationary objects*
- Small motorcycles, bicycles, pedestrians, etc.*
- Vehicles moving away from your vehicle
- Vehicles approaching from the parking spaces next to your vehicle*
- Objects which are extremely close to a radar sensor*
- Vehicles which are approaching from the right or left at the rear of the vehicle at a traveling speed of less than approximately 8 km/h (5 mph)
- Vehicles which are approaching from the right or left at the rear of the vehicle at a traveling speed of more than approximately 24 km/h (15 mph)

*: Depending on the conditions, detection of a vehicle and/or object may occur.

■ **Situations in which the system may operate even though there is no possibility of a collision**

In some situations such as the following, the Parking Support Brake function (rear-crossing vehicles) may operate even though there is no possibility of a collision.

- When the parking space faces a street and vehicles are being driven on the street

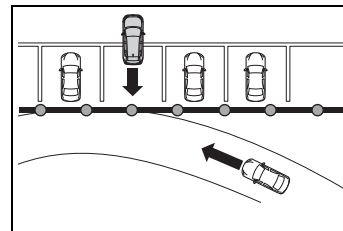

- When a detected vehicle turns while approaching the vehicle

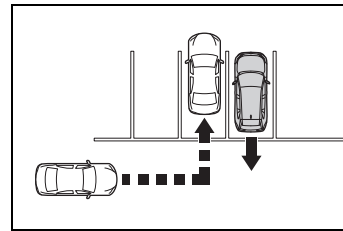

- When a vehicle passes by the side of your vehicle

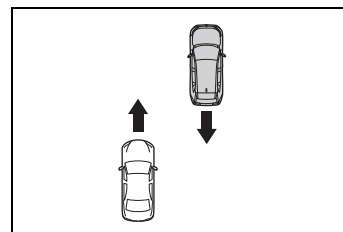

- When the distance between your vehicle and metal objects, such as a guardrail, wall, sign, or parked vehicle, which may reflect electrical waves toward the rear of the vehicle, is short

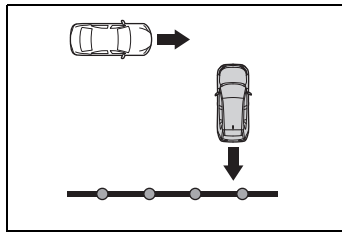

- When there are spinning objects near your vehicle such as the fan of an air conditioning unit
- When water is splashed or sprayed toward the rear bumper, such as from a sprinkler

■ **Situations in which the Parking Support Brake function (rear-crossing vehicles) may not operate properly**

In some situations, such as the following, the radar sensors may not detect an object and this function may not operate properly

- Stationary objects
- When a sensor or the area around a sensor is extremely hot or cold
- If the rear bumper is covered with ice, snow, dirt, etc.
- When it is raining heavily or water strikes the vehicle
- When the detection area of a radar sensor is obstructed by an adjacent vehicle
- If the vehicle is significantly tilted
- When equipment that may obstruct a sensor is installed, such as a towing eyelet, bumper protector (an additional trim strip, etc.), bicycle carrier, or snow plow
- If the suspension has been modified or tires of a size other than specified are installed
- If the front of the vehicle is raised or lowered due to the carried load
- If a sticker or an electronic component, such as a backlit license plate (especially fluorescent type), fog

lights, fender pole or wireless antenna is installed near a radar sensor

- If the orientation of a radar sensor has been changed
- When multiple vehicles are approaching with only a small gap between each vehicle
- If a vehicle is approaching the rear of your vehicle rapidly
- Situations in which the radar sensor may not detect a vehicle
- When a vehicle approaches from the right or left at the rear of the vehicle while you are turning while backing up
- When turning while backing up

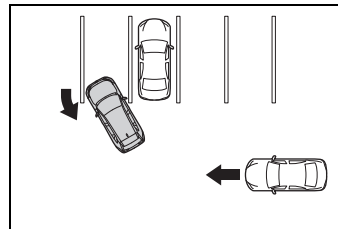

- When backing out of a shallow angle parking spot

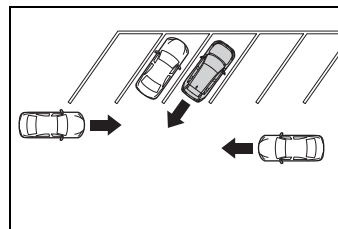

- When backing up on a slope with a sharp change in grade

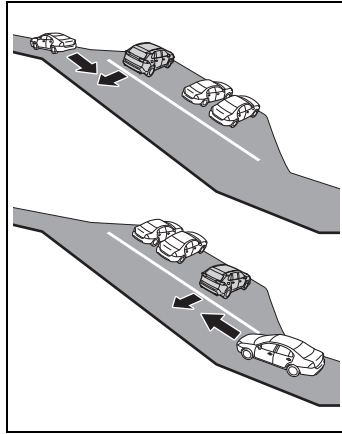

- When a vehicle turns into the detection area

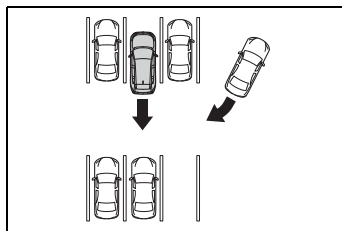

Driving mode select switch

The driving modes can be selected to suit the driving and usage conditions.

Selecting a driving mode

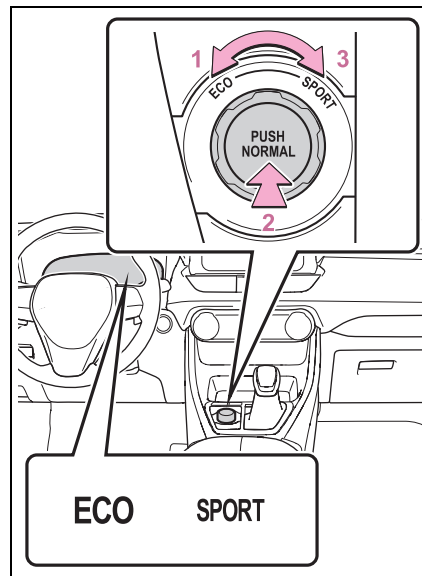

1 Eco drive mode

Suitable for driving to improve fuel economy by more smoothly generating torque in response to accelerator pedal operations compared to normal mode and restraining air conditioning system operations (heating/cooling).

When the switch is turned to the left while not in Eco drive mode, the system switches to Eco drive mode and the Eco drive mode indicator illuminates on the multi-information display.

2 Normal mode

Suitable for normal driving.

The driving mode returns to normal mode if the switch is pressed while in Eco drive mode or sport mode.

switch is turned off, normal mode and Eco drive mode will not be automatically canceled.)

3 Sport mode

Controls the steering feeling and hybrid system to create an acceleration response that is suitable for sporty driving. Suitable for when crisp handling is desired, such as when driving on mountainous roads.

When the switch is turned to the right while not in sport mode, the system switches to sport mode and the sport mode indicator illuminates on the multi-information display.

■ When changing to a driving mode other than normal mode

- The background color of the multi-information display changes according to the selected driving mode.
- When the speedometer is set to analog display, the speedometer display color also changes.
- The color of the switch changes according to the selected driving mode.

■ Air conditioning system operation in Eco drive mode

In Eco drive mode, heating/cooling operations and the fan speed is controlled to improve fuel efficiency. Perform the following procedures to increase the air conditioning performance.

- Adjust the fan speed (→P.407)
- Cancel Eco drive mode

■ Canceling a driving mode

- Sport mode is automatically canceled and the driving mode returns to normal mode when the power switch is turned off.
- Normal mode and Eco drive mode are not canceled until another driving mode is selected. (Even if the power

Trail Mode

Trail Mode is a system that performs integrated control for the AWD, brake and drive force control systems to assist the drive power on bumpy roads, etc.

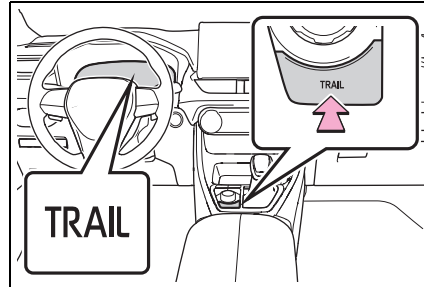

WARNING

■ Before using Trail Mode

Make sure to observe the following precautions. Failure to observe these precautions may result in an unexpected accident.

- Check that the Trail Mode indicator is illuminated before driving. Trail Mode will not operate when the indicator is off.
- Trail Mode is not intended to expand the limits of the vehicle. Thoroughly check the road conditions and drive with caution.
- Thoroughly check the road conditions before driving. As Trail Mode is suitable for driving on bumpy roads, such as those where the tire on one side spins, there is a chance that Trail Mode may not be the most appropriate for other road conditions.

Turning Trail Mode on

Press the Trail Mode switch

When the switch is pressed, Trail Mode turns on and the Trail Mode indicator illuminates on the multi-information display.

When the switch is pressed again, the Trail Mode indicator turns off.

■ Trail Mode

- Trail Mode is intended for use when driving on bumpy rough roads. Do not turn the switch on in other situations.
- Trail Mode controls the vehicle so that it can use the maximum amount of drive force when driving on bumpy roads.
- If Trail Mode is continuously used for a long period of time, the load on related parts increases and the system may be unable to operate effectively.

■ When Trail Mode is canceled

In the following situations, Trail Mode is automatically canceled even if it is turned on.

- When the driving mode is changed (→P.388)
- When the power switch is turned off

■ During Trail Mode operation

The following types of situations may occur, but they are not malfunctions.

- Vibrations may be felt throughout the vehicle or steering wheel
- Operating noise may be heard from the engine compartment

■ When an inspection at a SUZUKI dealer or a qualified workshop is necessary

In the following situations, the system may be malfunctioning. Have the vehicle inspected by a SUZUKI dealer or a qualified workshop immediately.

- When the slip indicator light illumi-

notes while Trail Mode is on

- When the Trail Mode indicator does not illuminate even though the Trail Mode switch is pressed

GPF (Gasoline Particulate Filter) system

The GPF system collects particulate matter in the exhaust gas by using an exhaust gas filter. The system will operate to regenerate the filter automatically, depending on the vehicle conditions.

■ If “Exhaust Filter Full See Owner’s Manual” is shown on the multi-information display

- The message may be displayed while high load driving with particulate matter accumulating.
- Hybrid system output (engine speed) is restricted when a certain amount of particulate matter accumulates, however, it is possible to drive the vehicle unless the malfunction indicator lamp comes on.
- Particulate matter can accumulate more quickly if the vehicle is frequently driven short trips or at low speeds, or if the hybrid system is regularly started in an extremely cold environment. Excessive accumulation of particulate matter can be prevented by periodically driving long distances continuously with intermittent releasing of the accelerator pedal, such as when driving on highways and freeways.

■ If the malfunction indicator lamp comes on or “Hybrid System Malfunction Output Power Reduced Visit Your Dealer” is shown on the multi-information display

The amount of accumulated particulate matter has exceeded a certain level. Have the vehicle inspected by a SUZUKI dealer or a qualified workshop immediately.



NOTICE

- **To prevent the GPF system from not operating properly**
- Do not use fuel other than the specified type
- Do not modify the exhaust pipes

Driving assist systems

To keep driving safety and performance, the following systems operate automatically in response to various driving situations. Be aware, however, that these systems are supplementary and should not be relied upon too heavily when operating the vehicle.

Summary of the driving assist systems

■ **ECB (Electronically Controlled Brake System)**

The electronically controlled system generates braking force corresponding to the brake operation

■ **ABS (Anti-lock Brake System)**

Helps to prevent wheel lock when the brakes are applied suddenly, or if the brakes are applied while driving on a slippery road surface

■ **Brake assist**

Generates an increased level of braking force after the brake pedal is depressed when the system detects a panic stop situation

■ **VSC (Vehicle Stability Control)**

Helps the driver to control skidding when swerving suddenly or turning on slippery road surfaces.

■ VSC+ (Vehicle Stability Control+)

Provides cooperative control of the ABS, TRC, VSC and EPS.

Helps to maintain directional stability when swerving on slippery road surfaces by controlling steering performance.

■ Trailer Sway Control

Helps the driver to control trailer sway by selectively applying brake pressure for individual wheels and reducing driving torque when trailer sway is detected.

■ TRC (Traction Control)

Helps to maintain drive power and prevent the drive wheels from spinning when starting the vehicle or accelerating on slippery roads

■ Active Cornering Assist (ACA)

Helps to prevent the vehicle from drifting to the outer side by performing inner wheel brake control when attempting to accelerate while turning

■ Hill-start assist control

Helps to reduce the backward movement of the vehicle when starting on an uphill

■ EPS (Electric Power Steering)

Employs an electric motor to reduce the amount of effort needed to turn the steering wheel

■ E-Four (Electronic On-Demand AWD system)

Automatically switches from front wheel drive to all-wheel drive (AWD) according to the driving conditions, helping to ensure reliable handling and stability. Examples of conditions where the system will switch to AWD are when cornering, going uphill, starting off or accelerating, and when the road surface is slippery due to snow, rain, etc.

■ Emergency brake signal

When the brakes are applied suddenly, the emergency flashers automatically flash to alert the vehicle behind.

■ The Secondary Collision Brake

When the SRS airbag sensor detects a collision and the system operates, the brakes and brake lights are automatically controlled to reduce the vehicle speed and help reduce the possibility of further damage due to a secondary collision.

■ When the TRC/VSC/ABS/Trailer Sway Control systems are operating

The slip indicator light will flash while the TRC/VSC/ABS/Trailer Sway Control systems are operating.

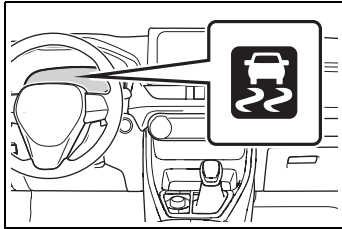

■ **Disabling the TRC system**

If the vehicle gets stuck in mud, dirt or snow, the TRC system may reduce power from the hybrid system to the wheels.

Pressing  to turn the system off may make it easier for you to rock the vehicle in order to free it.

To turn the TRC system off, quickly press and release .

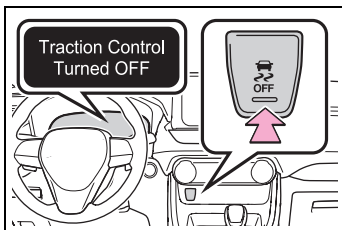

“Traction Control Turned OFF” will be shown on the multi-information display.

Press  again to turn the system back on.

■ **Turning off the TRC/VSC/Trailer Sway Control systems**

To turn the TRC/VSC/Trailer Sway Control systems off, press and hold  for more than 3 seconds while the vehicle is stopped.

The VSC OFF indicator light will come on and the “Traction Control Turned OFF” will be shown on the multi-information display.*

Press  again to turn the systems back on.

*: PCS will also be disabled (only Pre-

Collision warning is available). The PCS warning light will come on and a message will be displayed on the multi-information display. (→P.323)

■ **When the message is displayed on the multi-information display showing that TRC has been disabled**

even if  has not been pressed

TRC is temporary deactivated. If the information continues to show, contact a SUZUKI dealer or a qualified workshop.

■ **Operating conditions of hill-start assist control**

When the following four conditions are met, the hill-start assist control will operate:

- The shift lever is in a position other than P or N (when starting off forward/backward on an upward incline).
- The vehicle is stopped.
- The accelerator pedal is not depressed.
- The parking brake is not engaged.

■ **Automatic system cancelation of hill-start assist control**

The hill-start assist control will turn off in any of the following situations:

- The shift lever is shifted to P or N.
- The accelerator pedal is depressed.
- The parking brake is engaged.
- No more than 2 seconds have elapsed after the brake pedal is released.

■ **Sounds and vibrations caused by the ABS, brake assist, VSC, Trailer Sway Control, TRC and hill-start assist control systems**

- A sound may be heard from the engine compartment when the brake pedal is depressed repeatedly, when the hybrid system is started or just after the vehicle begins to move. This sound does not indicate that a malfunction has occurred in any of these systems.

- Any of the following conditions may occur when the above systems are operating. None of these indicates that a malfunction has occurred.
- Vibrations may be felt through the vehicle body and steering.
- A motor sound may be heard also after the vehicle comes to a stop.

■ **ECB operating sound**

ECB operating sound may be heard in the following cases, but it does not indicate that a malfunction has occurred.

- Operating sound heard from the engine compartment when the brake pedal is operated.
- Motor sound of the brake system heard from the front part of the vehicle when the driver' door is opened.
- Operating sound heard from the engine compartment when one or two minutes passed after the stop of the hybrid system.

■ **Active Cornering Assist operation sounds and vibrations**

When the Active Cornering Assist is operated, operation sounds and vibrations may be generated from the brake system, but this is not a malfunction.

■ **EPS operation sound**

When the steering wheel is operated, a motor sound (whirring sound) may be heard. This does not indicate a malfunction.

■ **Automatic reactivation of TRC, Trailer Sway Control and VSC systems**

After turning the TRC, Trailer Sway Control and VSC systems off, the systems will be automatically re-enabled in the following situations:

- When the power switch is turned off.
- If only the TRC system is turned off, the TRC will turn on when vehicle speed increases.
If both the TRC and VSC systems are turned off, automatic re-enabling will not occur when vehicle speed

increases.

■ **Operating conditions of Active Cornering Assist**

The system operates when the following occurs.

- TRC/VSC can operate
- The driver is attempting to accelerate while turning
- The system detects that the vehicle is drifting to the outer side
- The brake pedal is released

■ **Reduced effectiveness of the EPS system**

The effectiveness of the EPS system is reduced to prevent the system from overheating when there is frequent steering input over an extended period of time. The steering wheel may feel heavy as a result. Should this occur, refrain from excessive steering input or stop the vehicle and turn the hybrid system off. The EPS system should return to normal within 10 minutes.

■ **Operating conditions of emergency brake signal**

When the following conditions are met, the emergency brake signal will operate:

- The emergency flashers are off.
- Actual vehicle speed is over 55 km/h (35 mph).
- The system judges from the vehicle deceleration that it is a sudden braking operation.

■ **Automatic system cancelation of emergency brake signal**

The emergency brake signal will be canceled in any of the following situations:

- The emergency flashers are turned on.
- The system judges from the vehicle deceleration that is not a sudden braking operation.

■ **Secondary Collision Brake operating conditions**

The system operates when the SRS air-

bag sensor detects a collision while the vehicle is in motion. However, the system does not operate in any of the following situations.

- The vehicle speed is below 10 km/h (6 mph)
- Components are damaged

■ **Secondary Collision Brake automatic cancellation**

The system is automatically canceled in any of the following situations.

- The vehicle speed drops below approximately 10 km/h (6 mph)
- A certain amount of time elapses during operation
- The accelerator pedal is depressed a large amount

■ **If a message about AWD is shown on the multi-information display**

Perform the following actions.

Message	Details/Actions
“AWD System Overheated Switching to 2WD Mode”	<p>AWD system is overheating.</p> <p>→ Drive the vehicle at low speeds and stop the vehicle in a safe place with the engine running until the message is cleared.</p> <p>Once the display message on the multi-information display turns off, there is no problem continuing to drive. If the message does not disappear, have your vehicle checked by a SUZUKI dealer or a qualified workshop immediately.</p>
“AWD System Overheated 2WD Mode Engaged”	<p>The vehicle switched from all-wheel drive (AWD) to front wheel drive due to overheating.</p> <p>→ Drive the vehicle at low speeds and stop the vehicle in a safe place with the engine running until the message is cleared.</p> <p>Once the display message on the multi-information display turns off, the AWD system returns to normal. If the message does not disappear, have your vehicle checked by a SUZUKI dealer or a qualified workshop immediately.</p>
“AWD System Malfunction 2WD Mode Engaged Visit Your Dealer”	<p>A malfunction occurred in the AWD system.</p> <p>→ Have your vehicle checked by a SUZUKI dealer or a qualified workshop immediately.</p>

**WARNING****■ The ABS does not operate effectively when**

- The limits of tire gripping performance have been exceeded (such as excessively worn tires on a snow covered road).
- The vehicle hydroplanes while driving at high speed on wet or slick roads.

■ Stopping distance when the ABS is operating may exceed that of normal conditions

The ABS is not designed to shorten the vehicle's stopping distance. Always maintain a safe distance from the vehicle in front of you, especially in the following situations:

- When driving on dirt, gravel or snow-covered roads
- When driving over bumps in the road
- When driving over roads with potholes or uneven surfaces

■ TRC/VSC may not operate effectively when

Directional control and power may not be achievable while driving on slippery road surfaces, even if the TRC/VSC system is operating. Drive the vehicle carefully in conditions where stability and power may be lost.

■ Active Cornering Assist does not operate effectively when

- Do not overly rely on Active Cornering Assist. Active Cornering Assist may not operate effectively when accelerating down slopes or driving on slippery road surfaces.
- When Active Cornering Assist frequently operates, Active Cornering Assist may temporarily stop operating to ensure proper operation of the brakes, TRC and VSC.

■ Hill-start assist control does not operate effectively when

- Do not overly rely on hill-start assist control. Hill-start assist control may not operate effectively on steep inclines and roads covered with ice.
- Unlike the parking brake, hill-start assist control is not intended to hold the vehicle stationary for an extended period of time. Do not attempt to use hill-start assist control to hold the vehicle on an incline, as doing so may lead to an accident.

■ When the TRC/ABS/VSC/Trailer Sway Control is activated

The slip indicator light flashes. Always drive carefully. Reckless driving may cause an accident. Exercise particular care when the indicator light flashes.

■ When the TRC/VSC/Trailer Sway Control systems are turned off

Be especially careful and drive at a speed appropriate to the road conditions. As these are the systems to help ensure vehicle stability and driving force, do not turn the TRC/VSC/Trailer Sway Control systems off unless necessary.

Trailer Sway Control is part of the VSC system and will not operate if VSC is turned off or experiences a malfunction.

■ Replacing tires

Make sure that all tires are of the specified size, brand, tread pattern and total load capacity. In addition, make sure that the tires are inflated to the recommended tire inflation pressure level.

The ABS, TRC and VSC/Trailer Sway Control systems will not function correctly if different tires are installed on the vehicle.

Contact a SUZUKI dealer or a qualified workshop for further information when replacing tires or wheels.

**WARNING****■ Handling of tires and the suspension**

Using tires with any kind of problem or modifying the suspension will affect the driving assist systems, and may cause a system to malfunction.

■ Trailer Sway Control precaution

The Trailer Sway Control system is not able to reduce trailer sway in all situations. Depending on many factors such as the conditions of the vehicle, trailer, road surface and driving environment, the Trailer Sway Control system may not be effective. Refer to your trailer owner's manual for information on how to tow your trailer properly.

■ If trailer sway occurs

Observe the following precautions. Failing to do so may cause death or serious injury.

- Firmly grip the steering wheel.
Steer straight ahead. Do not try to control trailer swaying by turning the steering wheel.
- Begin releasing the accelerator pedal immediately but very gradually to reduce speed.
Do not increase speed. Do not apply vehicle brakes.

If you make no extreme correction with the steering or brakes, your vehicle and trailer should stabilize.

(→P.270)

■ Secondary Collision Brake

Do not rely solely upon the Secondary Collision Brake. This system is designed to help reduce the possibility of further damage due to a secondary collision, however, that effect changes according to various conditions. Overly relying on the system may result in death or serious injury.

Winter driving tips

Carry out the necessary preparations and inspections before driving the vehicle in winter. Always drive the vehicle in a manner appropriate to the prevailing weather conditions.

Pre-winter preparations

- Use fluids that are appropriate to the prevailing outside temperatures.
 - Engine oil
 - Engine coolant
 - Power control unit coolant
 - Washer fluid
- Have a service technician inspect the condition of the 12-volt battery.
- Have the vehicle fitted with four snow tires.

Ensure that all tires are the same size and brand.

 **WARNING**

■ **Driving with snow tires**

Observe the following precautions to reduce the risk of accidents. Failure to do so may result in a loss of vehicle control and cause death or serious injury.

- Use tires of the specified size.
- Maintain the recommended level of air pressure.
- Do not drive at speeds in excess of the speed limit or the speed limit specified for the snow tires being used.

- Use snow tires on all, not just some wheels.

 **NOTICE**

■ **Driving with tire chains**

Do not fit tire chains. Tire chains may damage the vehicle body and suspension, and adversely affect driving performance.

■ **Repairing or replacing snow tires**

Request repairs or replacement of snow tires from a SUZUKI dealer or a qualified workshop or legitimate tire retailers. This is because the removal and attachment of snow tires affects the operation of the tire pressure warning valves and transmitters.

Before driving the vehicle

Perform the following according to the driving conditions:

- Do not try to forcibly open a window or move a wiper that is frozen. Pour warm water over the frozen area to melt the ice. Wipe away the water immediately to prevent it from freezing.
- To ensure proper operation of the climate control system fan, remove any snow that has accumulated on the air inlet vents in front of the windshield.
- Check for and remove any excess ice or snow that may have accumulated on the exterior lights, vehicle's roof, chassis, around the tires or on the brakes.
- Remove any snow or mud from

the bottom of your shoes before getting in the vehicle.

When driving the vehicle

Accelerate the vehicle slowly, keep a safe distance between you and the vehicle ahead, and drive at a reduced speed suitable to road conditions.

When parking the vehicle

- Park the vehicle and move the shift lever to P without setting the parking brake. The parking brake may freeze up, preventing it from being released. If the vehicle is parked without setting the parking brake, make sure to block the wheels.

Failure to do so may be dangerous because it may cause the vehicle to move unexpectedly, possibly leading to an accident.

When the parking brake is in automatic mode, release the parking brake after shifting the shift lever to P. (→P.288)

- If the vehicle is left parked with the brakes damp in cold temperatures, there is a possibility of the brakes freezing.
- If the vehicle is parked without setting the parking brake, confirm that the shift lever cannot be moved out of P*.

*: The shift lever will be locked if it is attempted to be shifted from P to any other position without depressing the

brake pedal. If the shift lever can be shifted from P, there may be a problem with the shift lock system. Have the vehicle inspected by a SUZUKI dealer or a qualified workshop immediately.

WARNING

■ When parking the vehicle

When parking the vehicle without applying the parking brake, make sure to chock the wheels. If you do not chock the wheels, the vehicle may move unexpectedly, possibly resulting in an accident.

Selecting tire chains

Tire chains cannot be mounted.

Snow tires should be used instead.

Utility vehicle precautions

This vehicle belongs to the utility vehicle class, which has higher ground clearance and narrower tread in relation to the height of its center of gravity to make it capable of performing in a wide variety of off-road applications.

Utility vehicle feature

- Specific design characteristics give it a higher center of gravity than ordinary passenger cars. This vehicle design feature causes this type of vehicle to be more likely to rollover. And, utility vehicles have a significantly higher rollover rate than other types of vehicles.
- An advantage of the higher ground clearance is a better view of the road allowing you to anticipate problems.
- It is not designed for cornering at the same speeds as ordinary passenger cars any more than low-slung sports cars are designed to perform satisfactorily under off-road conditions. Therefore, sharp turns at excessive speeds may cause the vehicle to rollover.

WARNING

■ Utility vehicle precautions

Always observe the following precautions to minimize the risk of death, serious injury or damage to your vehicle:

- In a rollover crash, an unbelted person is significantly more likely to die than a person wearing a seat belt. Therefore, the driver and all passengers should always fasten their seat belts.
- Avoid sharp turns or abrupt maneuvers, if at all possible. Failure to operate this vehicle correctly may result in loss of control or vehicle rollover causing death or serious injury.
- Loading cargo on the roof luggage carrier (if equipped) will make the center of the vehicle gravity higher. Avoid high speeds, sudden starts, sharp turns, sudden braking or abrupt maneuvers, otherwise it may result in loss of control or vehicle rollover due to failure to operate this vehicle correctly.
- Always slow down in gusty crosswinds. Because of its profile and higher center of gravity, your vehicle is more sensitive to side winds than an ordinary passenger car. Slowing down will allow you to have better control.
- Do not drive horizontally across steep slopes. Driving straight up or straight down is preferred. Your vehicle (or any similar off-road vehicle) can tip over sideways much more easily than forward or backward.

Off-road driving

When driving your vehicle off-road, please observe the following pre-

cautions to ensure your driving enjoyment and to help prevent the closure of areas to off-road vehicles:

- Drive your vehicle only in areas where off-road vehicles are permitted to travel.
- Respect private property. Get owner's permission before entering private property.
- Do not enter areas that are closed. Honor gates, barriers and signs that restrict travel.
- Stay on established roads. When conditions are wet, driving techniques should be changed or travel delayed to prevent damage to roads.

 **WARNING**

■ **Off-road driving precautions**

Always observe the following precautions to minimize the risk of death, serious injury or damage to your vehicle:

- Drive carefully when off the road. Do not take unnecessary risks by driving in dangerous places.
- Do not grip the steering wheel spokes when driving off-road. A bad bump could jerk the wheel and injure your hands. Keep both hands and especially your thumbs on the outside of the rim.
- Always check your brakes for effectiveness immediately after driving in sand, mud, water or snow.

- After driving through tall grass, mud, rock, sand, rivers, etc., check that there is no grass, bush, paper, rags, stone, sand, etc. adhering or trapped on the underbody. Clear off any such matter from the underbody. If the vehicle is used with these materials trapped or adhering to the underbody, a breakdown or fire could occur.
- When driving off-road or in rugged terrain, do not drive at excessive speeds, jump, make sharp turns, strike objects, etc. This may cause loss of control or vehicle rollover causing death or serious injury. You are also risking expensive damage to your vehicle's suspension and chassis.

 **NOTICE**

■ **To prevent the water damage**

Take all necessary safety measures to ensure that water damage to the hybrid battery (traction battery), hybrid system or other components does not occur.

- Water entering the engine compartment may cause severe damage to the hybrid system.
- Water entering the hybrid transmission will cause deterioration in transmission quality. The malfunction indicator may come on, and the vehicle may not be drivable.
- Water can wash the grease from wheel bearings, causing rusting and premature failure, and may also enter the hybrid transaxle case, reducing the gear oil's lubricating qualities.



NOTICE

■ When you drive through water

If driving through water, such as when crossing shallow streams, first check the depth of the water and the bottom of the riverbed for firmness. Drive slowly and avoid deep water.

■ Inspection after off-road driving

- Sand and mud that has accumulated around brake discs may affect braking efficiency and may damage brake system components.
- Always perform a maintenance inspection after each day of off-road driving that has taken you through rough terrain, sand, mud, or water.

Interior features**6**

- 6-1. Using the air conditioning system and defogger**
 - Automatic air conditioning system**406**
 - Remote Air Conditioning System**413**
 - Heated steering wheel/seat heaters**415**
- 6-2. Using the interior lights**
 - Interior lights list.....**417**
- 6-3. Using the storage features**
 - List of storage features**420**
 - Luggage compartment features**424**
- 6-4. Using the other interior features**
 - Other interior features.....**427**

Automatic air conditioning system

Air outlets and fan speed are automatically adjusted according to the temperature setting.

Air conditioning controls

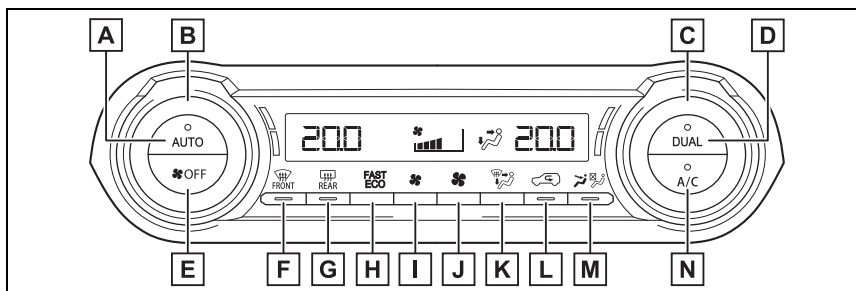

- A** Automatic mode switch
- B** Left-hand side temperature control switch
- C** Right-hand side temperature control switch
- D** “DUAL” switch
- E** “OFF” switch
- F** Windshield defogger switch
- G** Rear window defogger and outside rear view mirror defoggers switch
- H** Blower customization switch
- I** Fan speed decrease switch
- J** Fan speed increase switch
- K** Airflow mode control switch
- L** Outside/recirculated air mode switch
- M** S-FLOW mode switch
- N** “A/C” switch

The illustration is for left-hand drive vehicles. The button positions are reversed for right-hand drive vehicles.

■ Adjusting the temperature setting

Turn driver's side temperature control dial clockwise to increase the temperature and turn the dial counterclockwise to decrease the temperature.

The air conditioning system switches between individual and simultaneous modes each time the "DUAL" switch is pressed.

Simultaneous mode (the indicator on the "DUAL" switch is off):

The driver's side temperature control dial can be used to adjust the temperature for the driver's and passenger's side. At this time, operate the passenger's side temperature control dial to enter individual mode.

Individual mode (the indicator on the "DUAL" switch is on):

The temperature for the driver's and passenger's side can be adjusted separately.

■ Setting the fan speed

Press the fan speed increase switch to increase the fan speed and the fan speed decrease switch to decrease the fan speed.

Pressing the "OFF" switch turns off the fan.

■ Change the airflow mode

Press the airflow mode control switch.

The airflow mode changes as follows each time the switch is pressed.

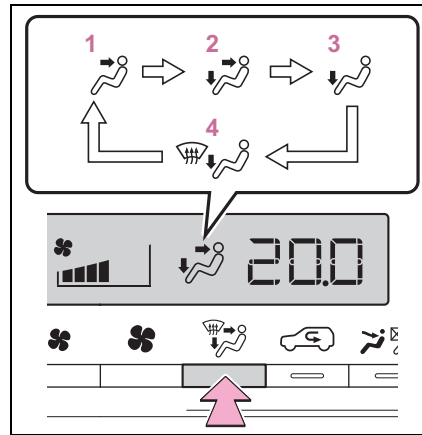

- 1 Upper body
- 2 Upper body and feet
- 3 Feet
- 4 Feet and the windshield defogger operates

■ Switching between outside air and recirculated air modes

Press the outside/recirculated air mode switch.

The mode switches between outside air mode (the indicator is off) and recirculated air mode (the indicator is on) each time the button is pressed.

■ Set cooling and dehumidification function

Press the "A/C" switch.

When the function is on, the indicator illuminates on the "A/C" switch.

■ Defogging the windshield

Defoggers are used to defog the windshield and front side windows.

Press the windshield defogger switch.

Set the outside/recirculated air mode

switch to outside air mode if the recirculated air mode is used. (It may switch automatically.)

To defog the windshield and the side windows quickly, turn the air flow and temperature up.

To return to the previous mode, press the windshield defogger switch again when the windshield is defogged.

When the windshield defogger switch is on, the indicator illuminates on the windshield defogger switch.

■ **Defogging the rear window and outside rear view mirrors**

Defoggers are used to defog the rear window, and to remove raindrops, dew and frost from the outside rear view mirrors.

Press the rear window defogger and outside rear view mirror defoggers switch.

The defoggers will automatically turn off after 15 minutes.

When the rear window defogger and outside rear view mirror defoggers switch is on, the indicator illuminates on the rear window defogger and outside rear view mirror defoggers switch.

■ **Blower customization**

The fan speed can be adjusted according to your preference.

- 1 Press the automatic mode or airflow mode control switch.
- 2 Press the blower customization switch.
- 3 Each time the blower customization switch is pressed, the fan speed changes as follows.

Normal → “ECO” → “FAST”

■ **Heating**

- In HV mode, the gasoline engine may operate in order to extract heat from the engine coolant via the heater.
- In EV mode, heating is done by a heat pump system.
- When the outside temperature is low or it is snowing, compared to conventional vehicles, heating may be less effective and warm air may not come out.
- When the outside heat exchanger is frosted over, fan speed declines and it may become harder to heat the interior. However, it is not a malfunction. In this situation, the air temperature from the outlets may not change even though the set temperature is raised.
- If frost has formed on the outside heat exchanger, the heating performance will decline. The frost can be removed from the outside heat exchanger by operating the Remote Air Conditioning System before driving (→P.413). When frosted over, the heating operation of the Remote Air Conditioning System starts after defrosting.
- When “AUTO” switch is turned on, the heating is controlled optimally. Therefore, the set heating performance may not be achieved even if the fan speed setting is increased.

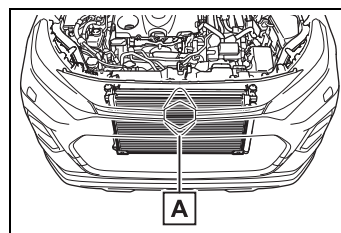

A Outside heat exchanger

- In the following situations the gasoline engine may operate in order to extract heat from the engine coolant via the heater even in EV mode.
- The outside temperature is approximately -10°C (14°F) or low

-  is operating

■ Water droplets during air conditioning operation

The outside heat exchanger, accumulator and air conditioning piping may incur condensation or frost may form. During or after the air conditioning operation, water droplets may fall from the vehicle. However, it is not a malfunction.

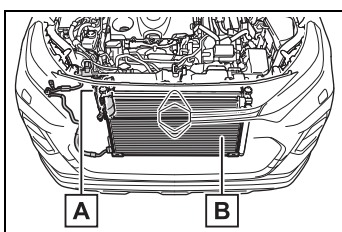

- A** Accumulator
- B** Outside heat exchanger

■ Fogging up of the windows

- The windows will easily fog up when the humidity in the vehicle is high. Turning “A/C” switch on will dehumidify the air from the outlets and defog the windshield effectively.
- If you turn “A/C” switch off, the windows may fog up more easily.
- The windows may fog up if the recirculated air mode is used.

■ While using “My Room Mode”

- It may not be possible to obtain the intended defogging performance even

if  is pressed. If the windows need to be defogged before driving, stop charging power and then press



- When the outside temperature is low, heating may feel insufficient due to restricted operation of the air conditioning. Heating cannot be performed when it is -10°C (14°F) or less as the

gasoline engine cannot be started during “My Room Mode”. If heating is desired, stop charging and remove the charging cable from the vehicle.

■ When driving on dusty roads

Close all windows. If dust thrown up by the vehicle is still drawn into the vehicle after closing the windows, it is recommended that the air intake mode be set to outside air mode and the fan speed to any setting except off.

■ Outside/recirculated air mode

- Setting to the recirculated air mode temporarily is recommended in preventing dirty air from entering the vehicle interior and helping to cool the vehicle when the outside air temperature is high.
- Outside/recirculated air mode may automatically switch depending on the temperature setting or the inside temperature.

■ Operation of the air conditioning system in Eco drive mode

- In Eco drive mode, the air conditioning system is controlled as follows to prioritize fuel efficiency:
 - Engine speed and compressor operation controlled to restrict heating/cooling capacity
 - Fan speed restricted when automatic mode is selected
- To improve air conditioning performance, perform the following operations:
 - Turn off Eco drive mode (→P.388)
 - Turn off blower customization (→P.408)

■ When the outside temperature falls to nearly 0°C (32°F)

The dehumidification function may not operate even when “A/C” switch is pressed.

■ Ventilation and air conditioning odors

- To let fresh air in, set the air conditioning system to the outside air mode.

- During use, various odors from inside and outside the vehicle may enter into and accumulate in the air conditioning system. This may then cause odor to be emitted from the vents.
- To reduce potential odors from occurring:
 - It is recommended that the air conditioning system be set to outside air mode prior to turning the vehicle off.
 - The start timing of the blower may be delayed for a short period of time immediately after the air conditioning system is started in automatic mode.
- When parking, the system automatically switches to outside air mode to encourage better air circulation throughout the vehicle, helping to reduce odors that occur when starting the vehicle.

■ **Air conditioning filter**

→P.473

■ **Noise from air conditioning system**

Approximately 90 seconds after the power switch turned to OFF, you may hear sound coming from air conditioning system. This is the sound of a air conditioning system initialize and, it does not indicate a malfunction.

■ **Customization**

Settings (e.g. A/C Auto switch operation) can be changed.
(Customizable features: →P.564)

 **WARNING**

■ **Cautions for using “My Room Mode”**

Do not leave children, people who need assistance, or pets inside the vehicle. The system may turn off automatically and the interior temperature may become high or low, resulting in heat stroke, dehydration or hypothermia. Failure to do so may result in death or serious injury.

■ **To prevent the windshield from fogging up**

Do not use the windshield defogger switch during cool air operation in extremely humid weather. The difference between the temperature of the outside air and that of the windshield can cause the outer surface of the windshield to fog up, blocking your vision.

■ **When the outside rear view mirror defoggers are operating**

Do not touch the rear view mirror surfaces when the outside rear view mirror defoggers are on.

 **NOTICE**

■ **To prevent 12-volt battery discharge**

Do not leave the air conditioning system on longer than necessary when the hybrid system is off.

Using automatic mode

- 1 Press the “AUTO” switch.

The dehumidification function begins to operate. Air outlets and fan speed are automatically adjusted according to the temperature setting and humidity.

- 2 Adjust the temperature setting.
- 3 To stop the operation, press the “OFF” switch.

If the fan speed setting or air flow modes are operated, the automatic mode indicator goes off. However, automatic mode for functions other than that operated is maintained.

■ **Using automatic mode**

Fan speed is adjusted automatically according to the temperature setting and the ambient conditions.

Therefore, the fan may stop for a while until warm or cool air is ready to flow immediately after the "AUTO" switch is pressed.

■ Windshield fog detection function

When automatic mode is set, the humidity sensor detects fog on the windshield and controls the air conditioning system to prevent fog.

Windshield wiper de-icer

This feature is used to prevent ice from building up on the windshield and wiper blades.

Press the switch to turn the system on/off.

The indicator comes on when the system is on.

The windshield wiper de-icer will automatically turn off after a period of time.

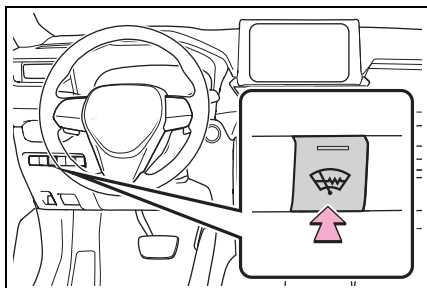

⚠ WARNING

■ To prevent burns

- Do not touch the glass at lower part of the windshield or to the side of the front pillars when the windshield wiper de-icer is on.

Front seat concentrated air-flow mode (S-FLOW)

This function automatically controls the air conditioning airflow so that

priority is given to the front seats. When the front passenger seat is not occupied, airflow may switch to only the driver's seat. Unnecessary air conditioning is suppressed, contributing to increased fuel efficiency.

Front seat concentrated airflow mode operates in the following situations.

- No passengers are detected in the rear seats
- The windshield defogger is not operating

While operating,  illuminates.

■ Manually turning front seat concentrated airflow mode on/off

In front seat concentrated airflow mode, directing airflow to the front seats only and to all seats can be switched via switch operation. When the mode has been switched manually, automatic airflow control stops operating.

Press the  on the air conditioning operation panel and switch the airflow.

- Indicator illuminated: Airflow to the front seats only
- Indicator off: Airflow to all the seats

■ Operation of automatic airflow control

- In order to maintain a comfortable interior, airflow may be directed to

seats without passengers immediately after the hybrid system is started and at other times depending on the outside temperature.

- After the hybrid system is started, if passengers move around inside or enter/exit the vehicle, the system cannot accurately detect the presence of passengers and automatic airflow control will not operate.

■ **Operation of manual airflow control**

Even if the function is manually switched to directing airflow to only the front seats, when a rear seat is occupied, it may automatically direct airflow to all seats.

■ **To return to automatic airflow control**

- 1 With the indicator off, turn the power switch off.
- 2 After 60 minutes or more elapse, turn the power switch to ON.

Air outlet layout and operations

■ **Location of air outlets**

The air outlets and air volume change according to the selected air flow mode.

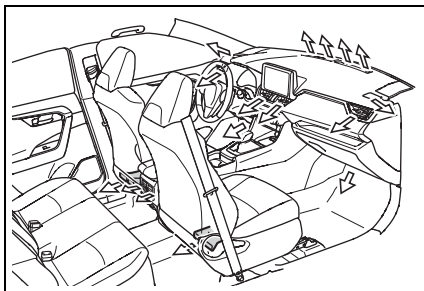

■ **Adjusting the air flow direction and opening/closing the air outlets**

► **Front**

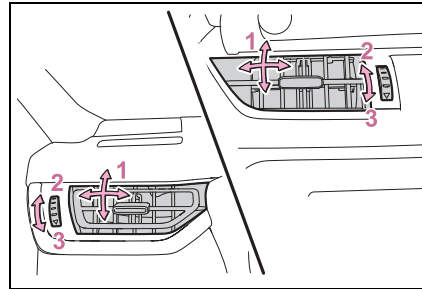

- 1 Direct air flow to the left or right, up or down
- 2 Open the vent
- 3 Close the vent

► **Rear**

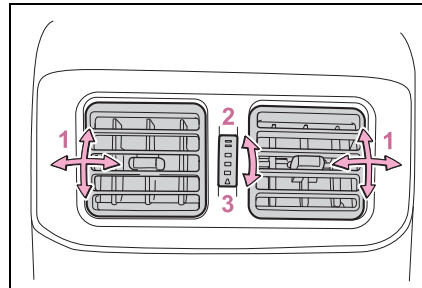

- 1 Direct air flow to the left or right, up or down
- 2 Open the vent
- 3 Close the vent

WARNING**■ To not interrupt the windshield defogger from operating**

Do not place anything on the instrument panel which may cover the air outlets. Otherwise, air flow may be obstructed, preventing the windshield defoggers from defogging.

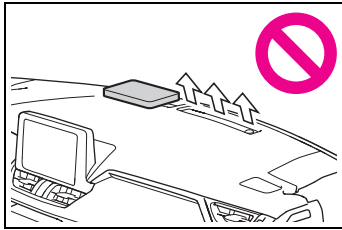
**NOTICE****■ Humidity sensor**

In order to detect fog on the windshield, a sensor which monitors the temperature of the windshield, the surround humidity, etc. is installed.

Follow these points to avoid damaging the sensor:

- Do not disassemble the sensor
- Do not spray the glass cleaner on the sensor or subject it to strong impacts
- Do not stick anything on the sensor

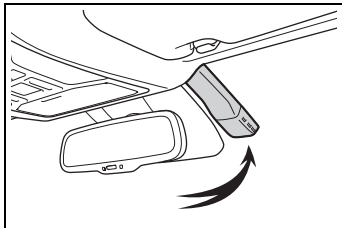
**Remote Air Conditioning System**

The Remote Air Conditioning System uses electrical energy stored in the hybrid battery (traction battery) and allows the air conditioning to be operated by remote control.

If the Remote Air Conditioning System is used while the charging cable is connected to the vehicle, electricity from an external power source can be used minimizing the drop in charge of the hybrid battery (traction battery).

Charging will be conducted automatically after the Remote Air Conditioning System is stopped.

Before leaving the vehicle

Check the temperature setting of the air conditioning system. (→P.406)

The Remote Air Conditioning System will operate in accordance with the temperature settings of the air conditioning system.

Activating the Remote Air Conditioning System

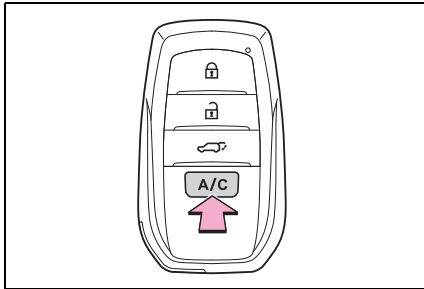

Press and hold “A/C” on the wireless remote control to operate the Remote Air Conditioning System.

The system can be stopped by pressing “A/C” twice.

Operating conditions

The system will only operate if all of the following conditions are met:

- The shift lever is in P.
- The power switch is off.
- All doors are closed.
- The hood is closed.

Remote Air Conditioning System automatic shut-off

The system will automatically shut off under the following conditions:

- About 20 minutes have passed since operation began
- Any one of the operating conditions is not met

The system may also shut off if the charge level of the hybrid battery (traction battery) drops to low.

Conditions affecting operation

The system may not start in the following situations:

- The charge level of the hybrid battery (traction battery) is low

- The outside temperature is extremely low
- When the hybrid system is cool (for example, after being left for a long time in low temperatures)

Windshield defogger

When defogging the windshield using the Remote Air Conditioning System, defogging may be insufficient due to the power being restricted more than during normal air conditioning operation. Also, the outside of the windshield may fog up due to the outside temperature, humidity or air conditioning set temperature.

Using the heater via the Remote Air Conditioning System

- When the outside temperature is low, heating may feel insufficient due to restricted operation of the air conditioning.
- When the outside heat exchanger becomes frosted over, heating performance may decline due to automatically switching to the frost removal operation. (→P.406)

Security feature

Any unlocked doors will be automatically locked when the system is operating. The emergency flashers flash to indicate that the doors have been locked or the system has been turned off.

Conditions affecting operation

→P.208

While the Remote Air Conditioning System is operating

- Depending on the operating condition of the Remote Air Conditioning System, the air conditioning compressor or cooling fan may spin and an operating noise may be heard. However, this does not indicate a malfunction.
- The air conditioning operation switches, etc. will not operate while the Remote Air Conditioning System is operating.

■ **Electronic key battery depletion**

→P.188

■ **When the electronic key battery is fully depleted**

→P.484

■ **Customization**

Setting (e.g. Operation using “A/C” on the wireless remote control) can be changed. (Customizable features:

→P.555)

 **WARNING**

■ **Precautions for the Remote Air Conditioning System**

- Do not use the system if people are in the vehicle.
Even when the system is in use, the internal temperature may still reach a high or low level due to features such as the automatic shut-off. Children and pets left inside the vehicle may suffer heatstroke dehydration or hypothermia, or could result in death or serious injury.
- Depending on the surrounding environment, signals from the wireless switch may transmit further than expected. Pay appropriate attention to the vehicle’s surroundings and use the switch only when necessary.
- Do not operate “A/C” on the wireless remote control if the hood is open. The air conditioning may operate unintentionally and objects may be drawn into the electrical cooling fan.

 **NOTICE**

■ **To prevent the hybrid battery (traction battery) from being discharged**

Use “A/C” on the wireless remote control only when necessary.

Heated steering wheel/seat heaters

● **Heated steering wheel**

Warm up the grip of the steering wheel

● **Seat heaters**

Warm up the seat upholstery

 **WARNING**

■ **To prevent minor burn injuries**

Care should be taken if anyone in the following categories comes in contact with the steering wheel or seats when the heater is on:

- Babies, small children, the elderly, the sick and the physically challenged
- Persons with sensitive skin
- Persons who are fatigued
- Persons who have taken alcohol or drugs that induce sleep (sleeping drugs, cold remedies, etc.)

■ **To prevent causes of overheating and minor burn injuries**

Observe the following precautions when using a seat heater:

- Do not cover the seat with a blanket or cushion when using the seat heater.
- Do not use seat heater more than necessary.

 **NOTICE**

■ **To prevent damage to the seat heaters and seat ventilators**

Do not put heavy objects that have an uneven surface on the seat and do not stick sharp objects (needles, nails, etc.) into the seat.

 **NOTICE**
■ To prevent 12-volt battery discharge
 Do not use the functions when the hybrid system is off.

Heated steering wheel

Turns the heated steering wheel on/off
 The indicator light comes on when the heated steering wheel is operating.

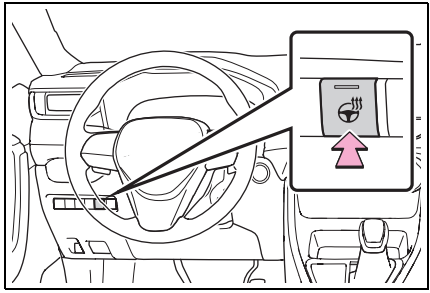

■ Operation condition
 The power switch is in ON.

Operating the seat heaters

► Front
 Turns the seat heaters on/off

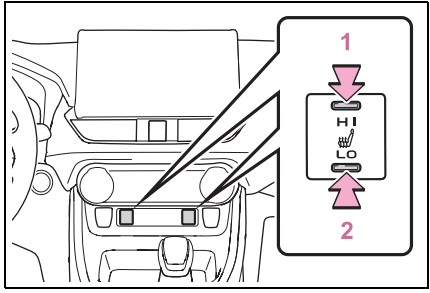

1 High temperature
2 Low temperature

When the seat heater is on, the indicator illuminates on the seat heater switch.
 When not in use, put the switch in the neutral position. The indicator will turn off.

► Rear
 Turns the seat heaters on/off
 The indicator light comes on when the seat heater is operating.

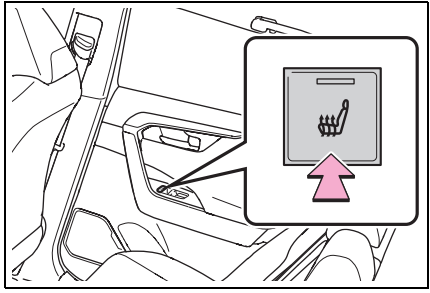

■ Operation condition
 The power switch is in ON.

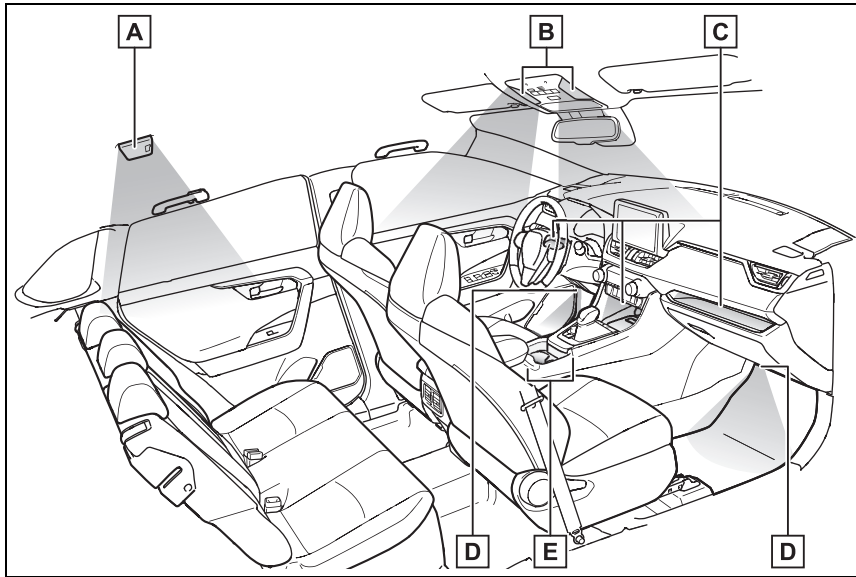
Interior lights list**Location of the interior lights**

- A** Rear interior light (→P.418)
- B** Front interior lights/personal lights (→P.418, 418)
- C** Open tray lights*
- D** Footwell lights*
- E** Front cup holder lights*

*: These lights turn on when a door is unlocked.

When the shift lever is in a position other than P, the brightness of these lights will reduce intensity.

Operating the interior lights

■ **Front interior lights**

Turns the lights on/off

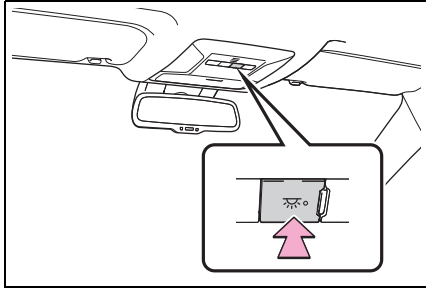

Turns the switch to the door position (door linked)

When a door is opened while the door position is on, the lights turn on.

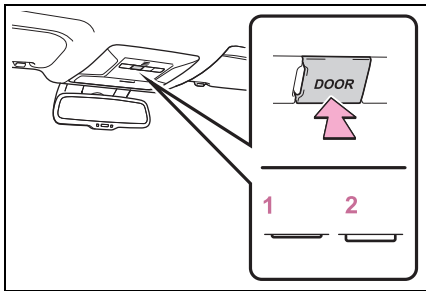

- 1 Turns the door position on
- 2 Turns the lights off

■ **Rear interior light**

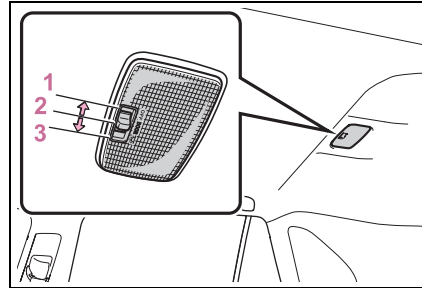

- 1 Turns the light off
- 2 Turns the door position on
- 3 Turns the light on

When a door is opened while the door position is on, the light turns on.

Operating the personal lights

Turns the lights on/off

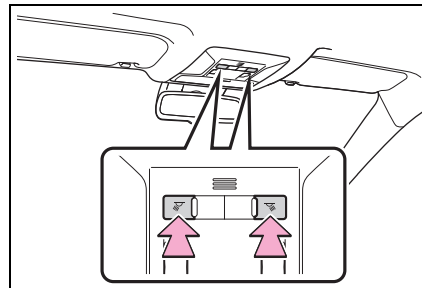

■ **Illuminated entry system**

The lights automatically turn on/off according to the power switch mode, the presence of the electronic key, whether the doors are locked/unlocked, and whether the doors are opened/closed.

■ **To prevent the 12-volt battery from being discharged**

If the interior lights remain on when the power switch is turned to OFF, the lights will go off automatically after 20 minutes.

■ The interior lights will turn on automatically when

If any of the SRS airbags deploy (inflate) or in the event of a strong rear impact, the interior lights will turn on automatically.

The interior lights will turn off automatically after approximately 20 minutes.

The interior lights can be turned off manually. However, in order to help prevent further collisions, it is recommended that they be left on until safety can be ensured.

(The interior lights may not turn on automatically depending on the force of the impact and conditions of the collision.)

■ Customization

Setting (e.g. the time elapsed before the lights turn off) can be changed. (Customizable features:→P.565)

**NOTICE****■ To prevent 12-volt battery discharge**

Do not leave the lights on longer than necessary when the hybrid system is off.

List of storage features

Location of the storage features

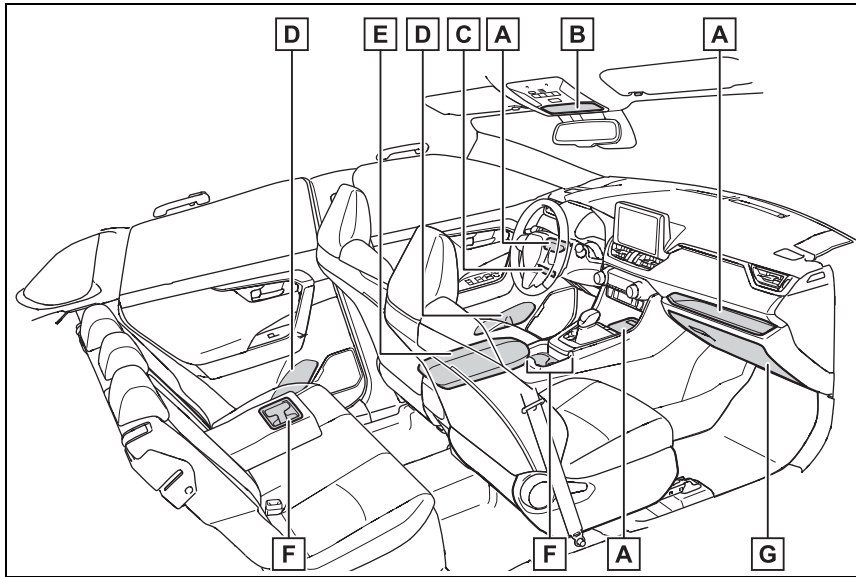

- A** Open tray (→P.423)
- B** Auxiliary box (→P.423)
- C** Card holder (if equipped) (→P.423)
- D** Bottle holders (→P.422)
- E** Console box (→P.421)
- F** Cup holders (→P.422)
- G** Glove box (→P.421)

⚠ WARNING**■ Items that should not be left in the vehicle**

Do not leave glasses, lighters or spray cans in the storage spaces, as this may cause the following when cabin temperature becomes high:

- Glasses may be deformed by heat or cracked if they come into contact with other stored items.
- Lighters or spray cans may explode. If they come into contact with other stored items, the lighter may catch fire or the spray can may release gas, causing a fire hazard.

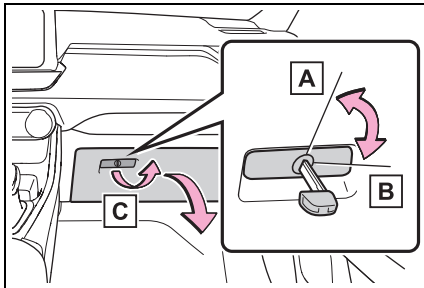
Glove box

- A** Unlock with the mechanical key
- B** Lock with the mechanical key
- C** Open (pull up the lever)

⚠ WARNING**■ Caution while driving**

Keep the glove box closed. In the event of sudden braking or sudden swerving, an accident may occur due to an occupant being struck by the open glove box or the items stored inside.

Console box

Lift the lid while pushing the button to release the lock.

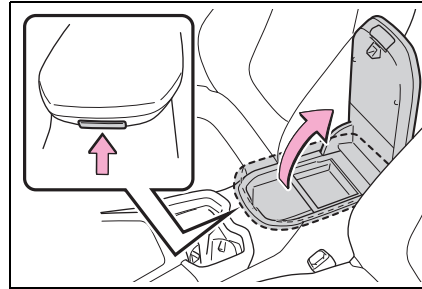
**■ Console box tray**

The tray can be removed and stored in the bottom of the console box.

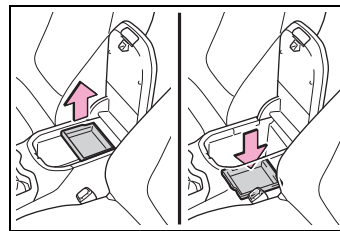
**⚠ WARNING****■ Caution while driving**

Keep the console box closed. Injuries may result in the event of an accident or sudden braking.

Cup holders

► Front

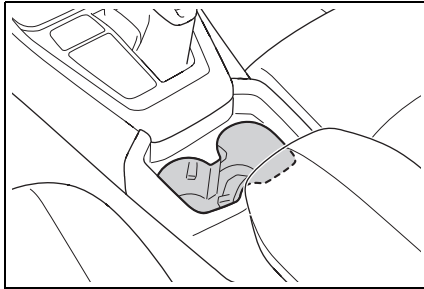

► Rear

Pull the armrest down

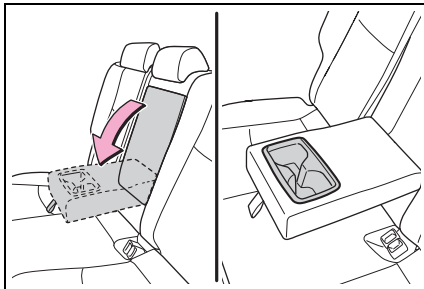

⚠ WARNING

■ Items unsuitable for the cup holders

Do not place anything other than cups or beverage cans in the cup holders. Inappropriate items must not be stored in the cup holders even if the lid is closed.

Other items may be thrown out of the holders in the event of an accident or sudden braking and cause injury. If possible, cover hot drinks to prevent burns.

Bottle holders

► Front

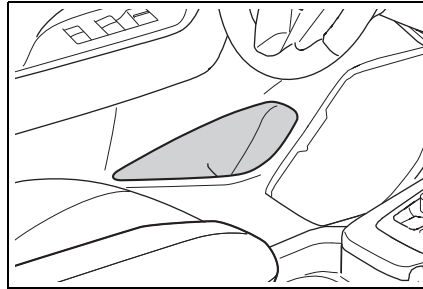

► Rear

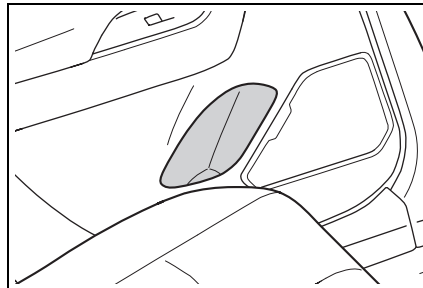

■ Bottle holders

- When storing a bottle, close the cap.
- The bottle may not be stored depending on its size or shape.

⚠ WARNING

■ Items unsuitable for the bottle holders

Do not place anything other than a bottle in the bottle holders. Other items may be thrown out of the holders in the event of an accident or sudden braking and cause injury.

**NOTICE****■ Items that should be not stowed in the bottle holders**

Do not place open bottles or glass and paper cups containing liquid in the bottle holders. The contents may spill and glasses may break.

Auxiliary box

Push the lid.

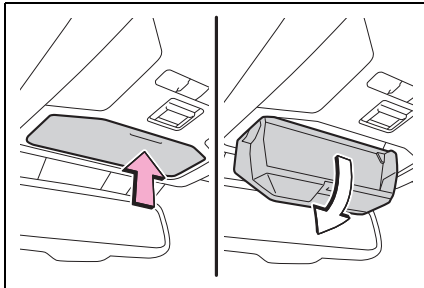
**WARNING****■ Caution while driving**

Do not leave the auxiliary box open while driving.

Injuries may result in the event of an accident or sudden braking.

■ Items unsuitable for storing

Do not store items heavier than 200 g (0.44 lb.).

Doing so may cause the auxiliary box to open and the items inside may fall out, resulting in an accident.

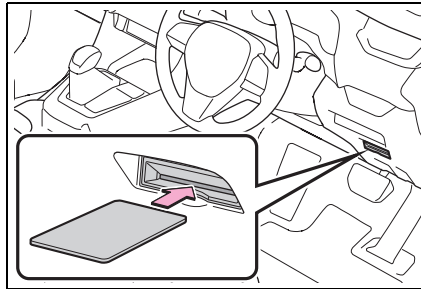
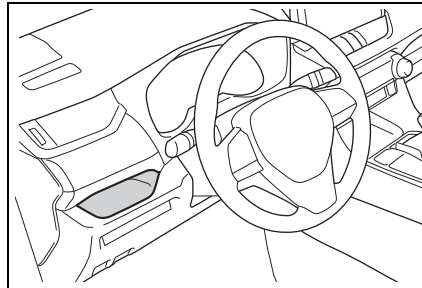
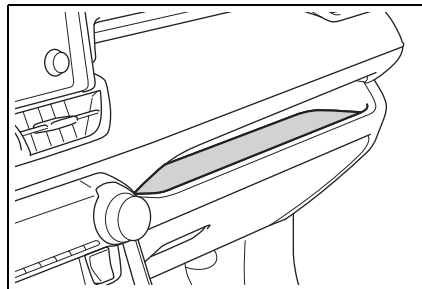
Card holder (right-hand drive vehicles)**Open tray****▶ Driver's side****▶ Front passenger's side**

► Front of console

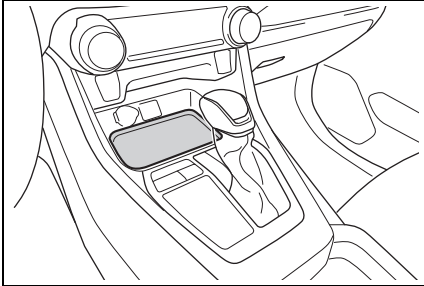

! WARNING

■ **Items unsuitable for the open tray**

Observe the following precautions when putting items in the open tray. Failure to do so may cause items to be thrown out of the tray in the event of sudden braking or steering. In these cases, the items may interfere with pedal operation or cause driver distraction, resulting in an accident.

- Do not store items in the tray that can easily shift or roll out.
- Do not stack items in the tray higher than the tray's edge.
- Do not put items in the tray that may protrude over the tray's edge.

Luggage compartment features

Cargo hooks

Raise the hook to use.

The cargo hooks are provided for securing loose items.

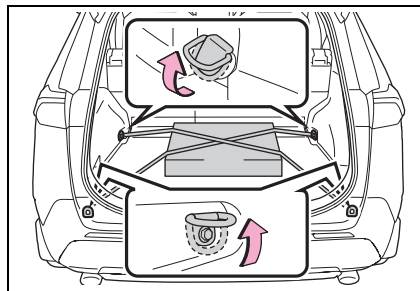

! WARNING

■ **When cargo hooks are not in use**

To avoid injury, always return the hooks to their stowed positions when not in use.

Deck board

Pull the tab and open the deck board.

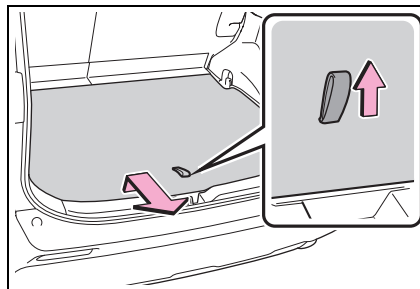

⚠ WARNING**■ When operating the deck board**

Do not place anything on the deck board when operating the board. Otherwise, your fingers may be caught or an accident may result causing injuries.

■ Caution while driving

Keep the deck board closed.

In the event of sudden braking, an accident may occur due to an occupant being struck by the deck board or the items stored under the deck board.

Deck under tray

Pull the tab and open the deck board.

The charging cable, etc., can be stored.

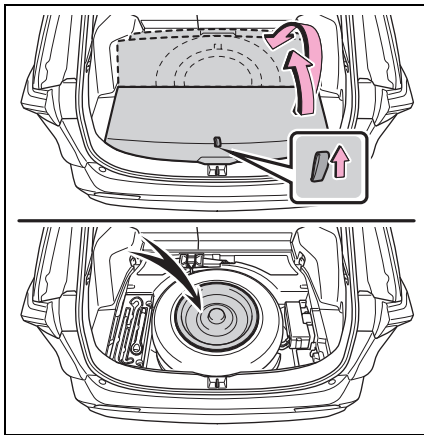
**⚠ WARNING****■ Caution while driving**

Keep the deck board closed.

In the event of sudden braking, an accident may occur due to an occupant being struck by the deck board or the items stored in the deck under tray.

Luggage cover**■ Installing the luggage cover**

- 1 Compress the both ends of the luggage cover and insert into the recess to install.

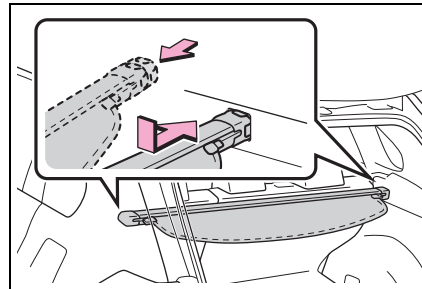

- 2 Pull out the luggage cover and hook it onto the anchors.

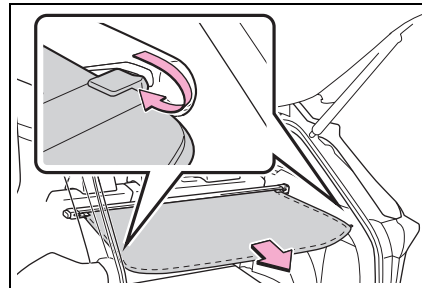
**■ Removing the luggage cover**

- 1 Release the cover from the left and right anchors and allow it to retract.

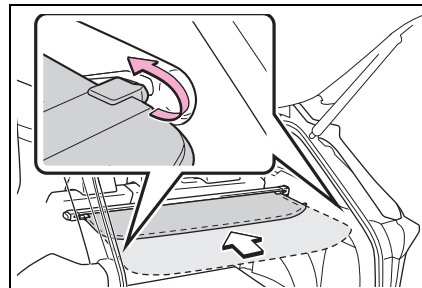

- 2 Compress the end of the luggage cover and lift the luggage cover up.

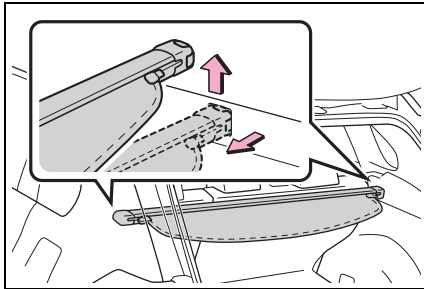

WARNING

■ **Luggage cover**

- When installing/stowing the luggage cover, make sure that the luggage cover is securely installed/stowed. Failure to do so may result in serious injury in the event of sudden braking or a collision.
- Do not place anything on the luggage cover. In the event of sudden braking or turning, the item may go flying and strike an occupant. This could lead to an unexpected accident, resulting in death or serious injury.
- Do not allow children to climb on the luggage cover. Climbing on the luggage cover could result in damage to the luggage cover, possibly causing death or serious injury to the child.

NOTICE

■ **To prevent damage to the luggage cover**

Do not place anything on top of the luggage cover. When rolling up the luggage cover, objects may be caught in the cover, damaging the cover and generating noise.

Other interior features

Sun visors

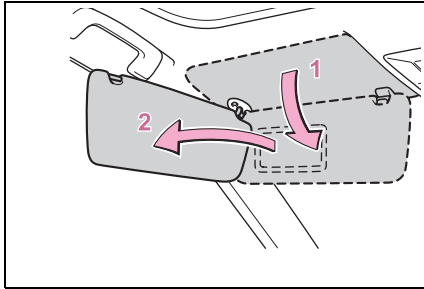

- 1 To set the visor in the forward position, flip it down.
- 2 To set the visor in the side position, flip down, unhook, and swing it to the side.

Vanity mirrors

Slide the cover to open.

The light turns on when the cover is opened.

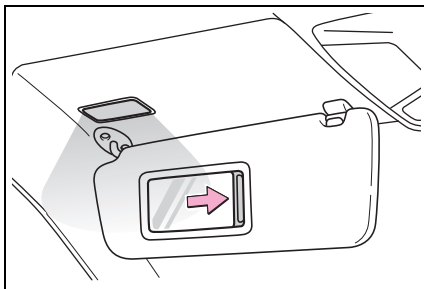

Automatic light off to prevent 12-volt battery discharge

If the vanity lights remain on when the power switch is turned to OFF, the lights will go off automatically after 20 minutes.

NOTICE

To prevent 12-volt battery discharge

Do not leave the vanity lights on for extended periods while the hybrid system is off.

Power outlet

The power outlet can be used for the following components:

12 V: Accessories that run on less than 10 A.

220 VAC: Accessories that use less than 150 W.

12 V

Front

Open the lid.

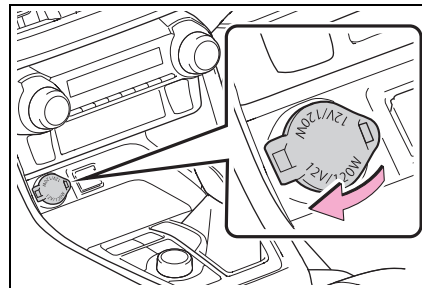

Console box

Open the console box and open the lid.

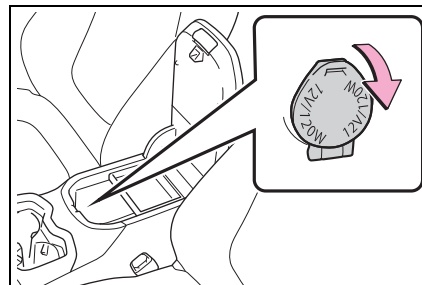

- ▶ Luggage compartment
Open the lid.

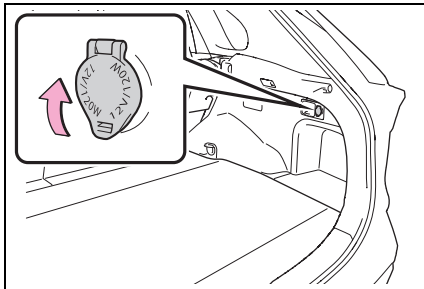

■ **220 VAC**

Open the lid.

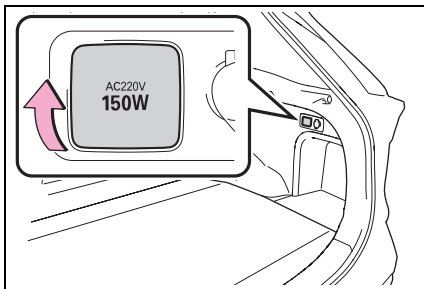

■ **The power outlet can be used when**

The power switch is in ON.

■ **When stopping the hybrid system**

Disconnect electrical devices with charging functions, such as mobile battery packs.

If such devices are left connected, the hybrid system may not stop normally.



NOTICE

■ **When power outlet is not in use**

To avoid damaging the power outlet, close the power outlet lid when the power outlet is not in use.

Foreign objects or liquids that enter the power outlet may cause a short circuit.

■ **To prevent blown fuse**

- 12 V: Do not use an accessory that uses more than 12 V 10 A.
- 220 VAC: Do not use a 220 VAC appliance that requires more than 150 W. If a 220 VAC appliance that consumes more than 150 W is used, the protection circuit will cut the power supply.

■ **To prevent 12-volt battery discharge**

Do not use the power outlet longer than necessary when the hybrid system is off.

■ **Appliances that may not operate properly (220 VAC)**

The following 220 VAC appliances may not operate properly even if their power consumption is under 150 W.

- Appliances with high initial peak wattage
- Measuring devices that process precise data
- Other appliances that require an extremely stable power supply

USB charging ports

The USB charging ports are used to supply 2.1 A of electricity at 5 V to external devices.

The USB charging ports are for charging only. They are not designed for data transfer or other purposes.

Depending on the external device, it may not charge properly. Refer to the manual included with the device before using a USB charging port.

■ **Using the USB charging ports**

Open the lid.

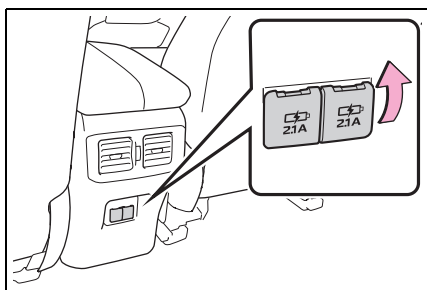

■ **The USB charging ports can be used when**

The power switch is in ACC or ON.

■ **Situations in which the USB charging ports may not operate correctly**

- If a device which consumes more than 2.1 A at 5 V is connected
- If a device designed to communicate with a personal computer, such as a USB memory device, is connected
- If the connected external device is turned off (depending on device)
- If the temperature inside the vehicle is high, such as after the vehicle has been parked in the sun

■ **About connected external devices**

Depending on the connected external device, charging may occasionally be suspended and then start again. This is not a malfunction.

 **NOTICE**

■ **To prevent damage to the USB charging ports**

- Do not insert foreign objects into the ports.
- Do not spill water or other liquids into the ports.
- When the USB charging ports are not in use, close the lids. If a foreign object or liquid enters a port may cause a short circuit.

- Do not apply excessive force to or impact the USB charging ports.

- Do not disassemble or modify the USB charging ports.

■ **To prevent damage to external devices**

- Do not leave external devices in the vehicle. The temperature inside the vehicle may become high, resulting in damage to an external device.

- Do not push down on or apply unnecessary force to an external device or the cable of an external device while it is connected.

■ **To prevent 12-volt battery discharge**

Do not use the USB charging ports for a long period of time when the hybrid system is off.

Armrest

Fold down the armrest for use.

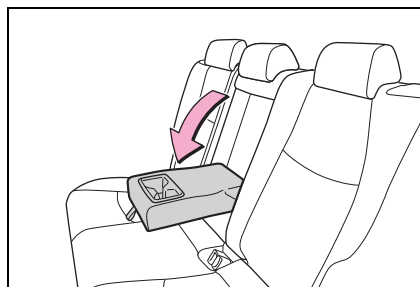

 **NOTICE**

■ **To prevent damage to the armrest**

Do not apply too much load on the armrest.

Assist grips

An assist grip installed on the ceiling can be used to support your

body while sitting on the seat.

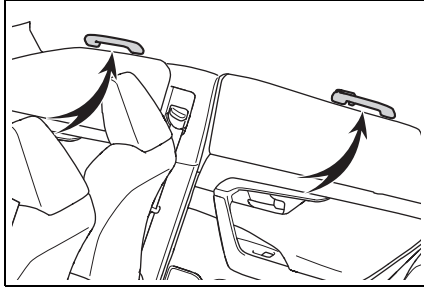

⚠ WARNING

■ **Assist grips**

Do not use the assist grip when getting in or out of the vehicle or rising from your seat.

⚠ NOTICE

■ **To prevent damage to the assist grip**

Do not hang any heavy object or put a heavy load on the assist grip.

Coat hooks

The coat hooks are provided with the rear assist grips.

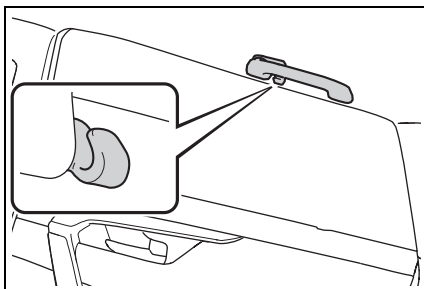

⚠ WARNING

■ **Items that must not be hanged on the hook**

Do not hang coat hangers or other hard or sharp objects on the hook. If the SRS curtain shield airbags deploy, these items may become projectiles, causing death or serious injury.

Maintenance and care**7****7-1. Maintenance and care**

- Cleaning and protecting the vehicle exterior**432**
- Cleaning and protecting the vehicle interior**435**

7-2. Maintenance

- Maintenance requirements**438**

7-3. Do-it-yourself maintenance

- Do-it-yourself service precautions**440**
- Hood**442**
- Positioning a floor jack.....**443**
- Engine compartment**445**
- 12-volt battery**450**
- Tires.....**452**
- Tire inflation pressure**471**
- Wheels.....**472**
- Air conditioning filter**473**
- Cleaning the DC/DC Converter air intake vent and filter**477**
- Wiper insert replacement..**481**
- Electronic key battery**484**
- Checking and replacing fuses**486**
- Light bulbs**489**

Cleaning and protecting the vehicle exterior

Perform the following to protect the vehicle and maintain it in prime condition:

Cleaning instructions

- Working from top to bottom, liberally apply water to the vehicle body, wheel wells and underside of the vehicle to remove any dirt and dust.
- Wash the vehicle body using a sponge or soft cloth, such as a chamois.
- For hard-to-remove marks, use car wash soap and rinse thoroughly with water.
- Wipe away any water.
- Wax the vehicle when the waterproof coating deteriorates.

If water does not bead on a clean surface, apply wax when the vehicle body is cool.

■ Before car washes

Check that the fuel filler door and charging port lid on your vehicle are closed properly.

■ Automatic car washes

- Before washing the vehicle:
 - Fold the mirrors
 - Turn off the power back door
- Start washing from the front of the vehicle. Make sure to extend the mirrors before driving.
- Brushes used in automatic car

washes may scratch the vehicle surface, parts (wheel, etc.) and harm your vehicle's paint.

- Rear spoiler may not be washable in some automatic car washes. There may also be an increased risk of damage to vehicle.

■ High pressure car washes

As water may enter the cabin, do not bring the nozzle tip near the gaps around the doors or perimeter of the windows, or spray these areas continuously.

■ Note for a smart entry & start system

If the door handle becomes wet while the electronic key is within the effective range, the door may lock and unlock repeatedly. In that case, follow the following correction procedures to wash the vehicle:

- Place the key in a position 2 m (6 ft.) or more separate from the vehicle while the vehicle is being washed. (Take care to ensure that the key is not stolen.)
- Set the electronic key to battery-saving mode to disable the smart entry & start system. (→P.207)

■ Wheels and wheel ornaments

- Remove any dirt immediately by using a neutral detergent.
- Wash detergent off with water immediately after use.
- To protect the paint from damage, make sure to observe the following precautions.
 - Do not use acidic, alkaline or abrasive detergent.
 - Do not use hard brushes.
 - Do not use detergent on the wheels when they are hot, such as after driving or parking in hot weather.

■ Front side windows water-repellent coating (except quarter window)

- The following precautions can extend

the effectiveness of the water-repellent coating.

- Remove any dirt, etc., from the front side windows regularly.
- Do not allow dirt and dust to accumulate on the windows for a long period. Clean the windows with a soft, damp cloth as soon as possible.
- Do not use wax or glass cleaners that contain abrasives when cleaning the windows.
- Do not use any metallic objects to remove condensation build up.

■ Bumpers

Do not scrub with abrasive cleaners.

■ Plated portions

If dirt cannot be removed, clean the parts as follows:

- Use a soft cloth dampened with an approximately 5% solution of neutral detergent and water to clean the dirt off.
- Wipe the surface with a dry, soft cloth to remove any remaining moisture.
- To remove oily deposits, use alcohol wet wipes or a similar product.



WARNING

■ When washing the vehicle

Do not apply water to the inside of the engine compartment. Doing so may cause the electrical components, etc. to catch fire.

■ When cleaning the windshield

Set the wiper switch to off.

If the wiper switch is in "AUTO", the wipers may operate unexpectedly in the following situations, and may result in hands being caught or other serious injuries and cause damage to the wiper blades.

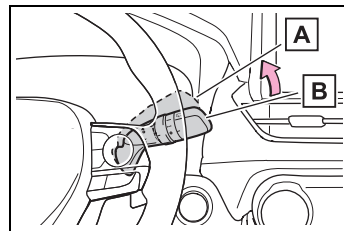

A Off

B "AUTO"

- When the upper part of the windshield where the raindrop sensor is located is touched by hand
- When a wet rag or similar is held close to the raindrop sensor
- If something bumps against the windshield
- If you directly touch the raindrop sensor body or if something bumps into the raindrop sensor

■ Precautions regarding the exhaust pipes

Exhaust gasses cause the exhaust pipes to become quite hot.

When washing the vehicle, be careful not to touch the pipes until they have cooled sufficiently, as touching hot exhaust pipes can cause burns.

■ Precaution regarding the rear bumper with Blind Spot Monitor

If the paint of the rear bumper is chipped or scratched, the system may malfunction. If this occurs, consult a SUZUKI dealer or a qualified workshop.



NOTICE

■ **To prevent paint deterioration and corrosion on the body and components (aluminum wheels, etc.)**

- Wash the vehicle immediately in the following cases:
 - After driving near the sea coast
 - After driving on salted roads
 - If coal tar or tree sap is present on the paint surface
 - If dead insects, insect droppings or bird droppings are present on the paint surface
 - After driving in an area contaminated with soot, oily smoke, mine dust, iron powder or chemical substances
 - If the vehicle becomes heavily soiled with dust or mud
 - If liquids such as benzene and gasoline are spilled on the paint surface
- If the paint is chipped or scratched, have it repaired immediately.
- To prevent the wheels from corroding, remove any dirt and store in a place with low humidity when storing the wheels.

■ **Cleaning the exterior lights**

- Wash carefully. Do not use organic substances or scrub with a hard brush. This may damage the surfaces of the lights.
- Do not apply wax to the surfaces of the lights. Wax may cause damage to the lenses.

■ **When using an automatic car wash**

Set the wiper switch to off position. If the wiper switch is in "AUTO", the wipers may operate and the wiper blades may be damaged.

■ **When using a high pressure car wash**

- When washing the vehicle, do not let water from the high-pressure washer directly hit the camera (if equipped) or the area around the camera. Due to the shock from the high pressure water, it is possible that the device may not operate normally.
- Do not bring the nozzle tip close to boots (rubber or resin manufactured cover), or connectors or the following parts. The parts may be damaged if they come into contact with high-pressure water.
 - Traction battery
 - Traction related parts
 - Steering parts
 - Suspension parts
 - Brake parts
- Keep the cleaning nozzle at least 30 cm (11.9 in.) away from the vehicle body. Otherwise resin section, such as moldings and bumpers, may be deformed and damaged. Also, do not continuously hold the nozzle in the same place.
- Do not spray the lower part of the windshield continuously. If water enters the air conditioning system intake located near the lower part of the windshield, the air conditioning system may not operate correctly.
- Do not wash the underside of the vehicle using a high pressure car washer.

**NOTICE**

- Do not use the washer on the area around the charging port lid. Water could get into the AC charging inlet and could damage the vehicle.

Cleaning and protecting the vehicle interior

Perform cleaning in a manner appropriate to each component and its material.

Protecting the vehicle interior

- Remove dirt and dust using a vacuum cleaner. Wipe dirty surfaces with a cloth dampened with lukewarm water.
- If dirt cannot be removed, wipe it off with a soft cloth dampened with neutral detergent diluted to approximately 1%.
Wring out any excess water from the cloth and thoroughly wipe off remaining traces of detergent and water.

Shampooing the carpets

There are several commercial foaming-type cleaners available. Use a sponge or brush to apply the foam. Rub in overlapping circles. Do not use water. Wipe dirty surfaces and let them dry. Excellent results are obtained by keeping the carpet as dry as possible.

Handling the seat belts

Clean with mild soap and lukewarm water using a cloth or sponge. Also check the belts periodically for excessive wear, fraying or cuts.

**WARNING****■ Water in the vehicle**

- Do not splash or spill liquid in the vehicle, such as on the floor, on the rear seats, in the DC/DC Converter air intake vent, junction box or in the luggage compartment. (→P.92) Doing so may cause the DC/DC Converter, electrical components, etc. to malfunction or catch fire.
- Do not get any of the SRS components or wiring in the vehicle interior wet. (→P.38)
An electrical malfunction may cause the airbags to deploy or not function properly, resulting in death or serious injury.

■ Cleaning the interior (especially instrument panel)

Do not use a polish wax or polish cleaner. The instrument panel may reflect off the windshield, obstructing the driver's view and leading to an accident, resulting in death or serious injury.

**NOTICE****■ Cleaning detergents**

- Do not use the following types of detergent, as they may discolor the vehicle interior or cause streaks or damage to painted surfaces:
 - Non-seat portions: Organic substances such as benzene or gasoline, alkaline or acidic solutions, dye, and bleach
 - Seats: Alkaline or acidic solutions, such as thinner, benzene, and alcohol
- Do not use a polish wax or polish cleaner. The instrument panel's or other interior part's painted surface may be damaged.

■ Preventing damage to leather surfaces

Observe the following precautions to avoid damage to and deterioration of leather surfaces:

- Remove any dust or dirt from leather surfaces immediately.
- Do not expose the vehicle to direct sunlight for extended periods of time. Park the vehicle in the shade, especially during summer.
- Do not place items made of vinyl, plastic, or containing wax on the upholstery, as they may stick to the leather surface if the vehicle interior heats up significantly.

■ Water on the floor

Do not wash the vehicle floor with water.

Vehicle systems such as the audio system may be damaged if water comes into contact with electrical components such as the audio system above or under the floor of the vehicle. Water may also cause the body to rust.

■ When cleaning the inside of the windshield (vehicles with Safety Sense)

Do not allow glass cleaner to contact the lens. Also, do not touch the lens. (→P.306)

■ Cleaning the inside of the rear window

- Do not use a glass cleaner to clean the rear window, as this may cause damage to the rear window defogger heater wires. Use a cloth dampened with lukewarm water to gently wipe the window clean. Wipe the window in strokes running parallel to the heater wires.
- Be careful not to scratch or damage the heater wires.

Cleaning the leather areas

- Remove dirt and dust using a vacuum cleaner.
- Wipe off any excess dirt and dust with a soft cloth dampened with diluted detergent.

Use a diluted water solution of approximately 5% neutral wool detergent.

- Wring out any excess water from the cloth and thoroughly wipe off all remaining traces of detergent.
- Wipe the surface with a dry, soft cloth to remove any remaining moisture. Allow the leather to dry in a shaded and ventilated area.

Caring for leather areas

Suzuki recommends cleaning the interior of the vehicle at least twice a year to maintain the quality of the vehicle's interior.

Cleaning the synthetic leather areas

- Remove dirt and dust using a vacuum cleaner.
- Wipe it off with a soft cloth dampened with neutral detergent diluted to approximately 1%.
- Wring out any excess water from the cloth and thoroughly wipe off remaining traces of detergent and water.

Maintenance requirements

To ensure safe and economical driving, day-to-day care and regular maintenance are essential. Suzuki recommends the maintenance below.

■ Where to go for maintenance service?

In order to maintain your vehicle in the best possible condition, Suzuki recommends that maintenance service operations as well as other inspections and repairs be carried out by a SUZUKI dealer or a qualified workshop. For repairs and services covered by your warranty, please visit an authorized Suzuki retailer or repairer, who will use genuine Suzuki parts in repairing any difficulties you may encounter. There can also be advantages in utilizing authorized Suzuki retailers or repairers for non-warranty repairs and services, as members of the Suzuki network will be able to expertly assist you with any difficulties you may encounter.

Your SUZUKI dealer or a qualified workshop will perform all of the scheduled maintenance on your vehicle reliably and economically due to their experience with Suzuki vehicles.



WARNING

■ If your vehicle is not properly maintained

Improper maintenance could result in serious damage to the vehicle and possible death or serious injury.

■ Handling of the 12-volt battery

12-volt battery posts, terminals and related accessories contain lead and lead compounds which are known to cause brain damage. Wash your hands after handling. (→P.450)

Scheduled maintenance

Scheduled maintenance should be performed at specified intervals according to the maintenance schedule.

For full details of your maintenance schedule, refer to the "Warranty and service record booklet".

Do-it-yourself maintenance

What about do-it-yourself maintenance?

Many maintenance items are easy to do yourself if you have a little mechanical ability and a few basic automotive tools.

Note, however, that some maintenance tasks require special tools and skills. These are best performed by qualified technicians. Even if you're an experienced do-it-yourself mechanic, we recommend that repairs and maintenance be conducted by a SUZUKI dealer or a qualified workshop. Any authorized Suzuki retailer or repairer will keep a record of maintenance, which could be useful should you ever require Warranty Service. Should you choose to select a qualified and equipped professional other than an authorized Suzuki repairer to service or maintain your vehicle, we recommend that you request that a record of maintenance

be kept.

■ Does your vehicle need repairs?

Be on the alert for changes in performance and sounds, and visual tip-offs that indicate service is needed. Some important clues are:

- Engine missing, stumbling or pinging
- Appreciable loss of power
- Strange engine noises
- A fluid leak under the vehicle (However, water dripping from the air conditioning system after use is normal.)
- Change in exhaust sound (This may indicate a dangerous carbon monoxide leak. Drive with the windows open and have the exhaust system checked immediately.)
- Flat-looking tires, excessive tire squeal when cornering, uneven tire wear
- Vehicle pulls to one side when driven straight on a level road
- Strange noises related to suspension movement
- Loss of brake effectiveness, spongy feeling brake pedal, pedal almost touches the floor, vehicle pulls to one side when braking
- Engine coolant temperature continually higher than normal (→P.166)

If you notice any of these clues, take your vehicle to a SUZUKI dealer or a qualified workshop as soon as possible. Your vehicle may need adjustment or repair.

Do-it-yourself service precautions

If you perform maintenance by yourself, be sure to follow the correct procedure as given in these sections.

Maintenance

Items	Parts and tools
12-volt battery condition (→P.450)	<ul style="list-style-type: none"> • Grease • Conventional wrench (for terminal clamp bolts)
Engine/power control unit coolant level (→P.447)	<ul style="list-style-type: none"> • “Toyota Super Long Life Coolant” or a similar high quality ethylene glycol-based non-silicate, non-amine, non-nitrite and non-borate coolant with long-life hybrid organic acid technology • “Toyota Super Long Life Coolant” is pre-mixed with 50% coolant and 50% deionized water. • Funnel (used only for adding coolant)
Engine oil level (→P.445)	<ul style="list-style-type: none"> • “SUZUKI GENUINE OIL” or equivalent • Rag or paper towel • Funnel (used only for adding engine oil)

Items	Parts and tools
Fuses (→P.486)	<ul style="list-style-type: none"> • Fuse with same amperage rating as original
Hybrid battery (traction battery) air intake vent (→P.477)	<ul style="list-style-type: none"> • Vacuum cleaner, etc, • Phillips screwdriver
Light bulbs (→P.489)	<ul style="list-style-type: none"> • Bulb with same number and wattage rating as original • Phillips-head screwdriver • Flathead screwdriver • Wrench
Radiator and condenser (→P.448)	—
Tire inflation pressure (→P.471)	<ul style="list-style-type: none"> • Tire pressure gauge • Compressed air source
Washer fluid (→P.449)	<ul style="list-style-type: none"> • Water or washer fluid containing anti-freeze (for winter use) • Funnel (used only for adding water or washer fluid)

 **WARNING**
 The engine compartment contains many mechanisms and fluids that may move suddenly, become hot, or become electrically energized. To avoid death or serious injury, observe the following precautions.

**WARNING****■ When working on the engine compartment**

- Make sure that “IGNITION ON” on the multi-information display and the “READY” indicator are both off.
- Keep hands, clothing and tools away from the moving fan.
- Be careful not to touch the engine, power control unit, radiator, exhaust manifold, etc. right after driving as they may be hot. Oil and other fluids may also be hot.
- Do not leave anything that may burn easily, such as paper and rags, in the engine compartment.
- Do not smoke, cause sparks or expose an open flame to fuel or the 12-volt battery. Fuel and 12-volt battery fumes are flammable.
- Take care because brake fluid can harm your hands or eyes and damage painted surfaces. If fluid gets on your hands or in your eyes, flush the affected area with clean water immediately. If you still experience discomfort, consult a doctor.

■ When working near the electric cooling fan or radiator grille

Be sure the power switch is off. With the power switch in ON, the electric cooling fan may automatically start to run if the air conditioning is on and/or the coolant temperature is high. (→P.448)

■ Safety glasses

Wear safety glasses to prevent flying or falling material, fluid spray, etc., from getting in your eyes.

**NOTICE****■ If you remove the air cleaner filter**

Driving with the air cleaner filter removed may cause excessive engine wear due to dirt in the air.

■ If the fluid level is low or high

It is normal for the brake fluid level to go down slightly as the brake pads wear or when the fluid level in the accumulator is high.

If the reservoir needs frequent refilling, it may indicate a serious problem.

Hood

Release the lock from the inside of the vehicle to open the hood.

Opening the hood

- 1 Pull the hood lock release lever. The hood will pop up slightly.

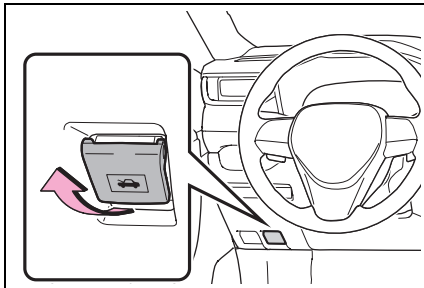

- 2 Push the auxiliary catch lever to the left and lift the hood.

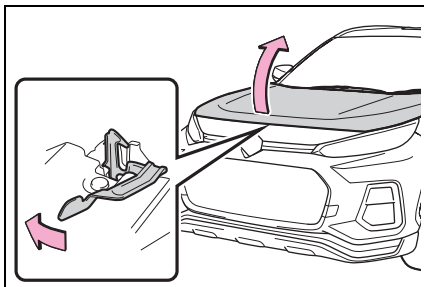

- 3 Hold the hood open by inserting the supporting rod into the slot.

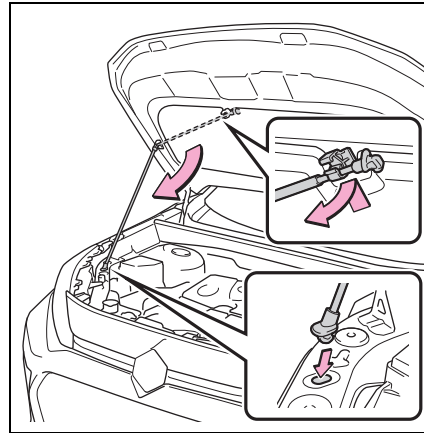

⚠ WARNING

■ Pre-driving check

Check that the hood is fully closed and locked.

If the hood is not locked properly, it may open while the vehicle is in motion and cause an accident, which may result in death or serious injury.

■ To prevent burns

Do not touch the pipes when the compressor is operating or after it is stopped, because the pipes are hot.

Touching by hands before the pipes cool down may cause burns.

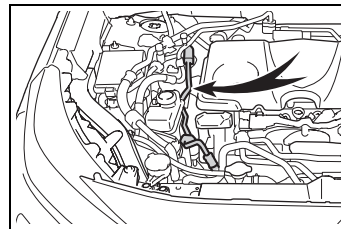

■ After installing the support rod into the slot

Make sure the rod supports the hood securely from falling down on to your head or body.

⚠ WARNING**■ When closing the hood**

When closing the hood, take extra care to prevent your fingers etc. from being caught.

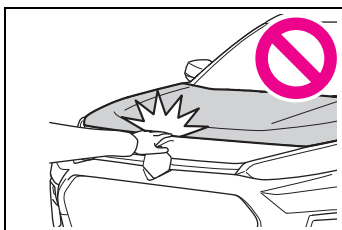
**⚠ NOTICE****■ When closing the hood**

Be sure to return the support rod to its clip before closing the hood. Closing the hood without returning the support rod properly could cause the hood to bend.

Positioning a floor jack

When using a floor jack, follow the instructions in the manual provided with the jack and perform the operation safely.

When raising your vehicle with a floor jack, position the jack correctly.

Improper placement may damage your vehicle or cause injury.

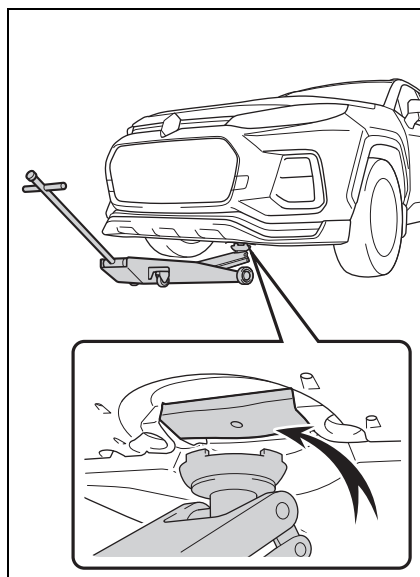
Location of the jack point**■ Front**

■ Rear

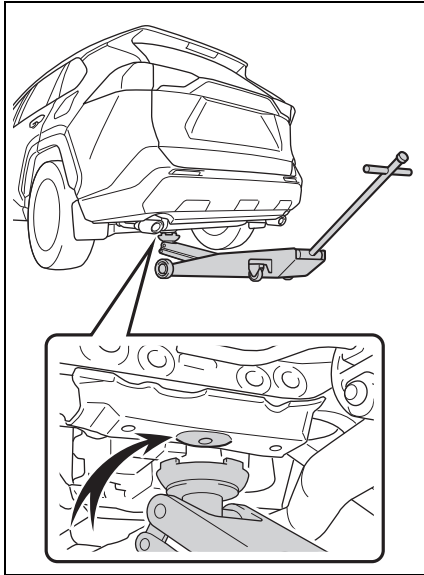

Engine compartment

Components

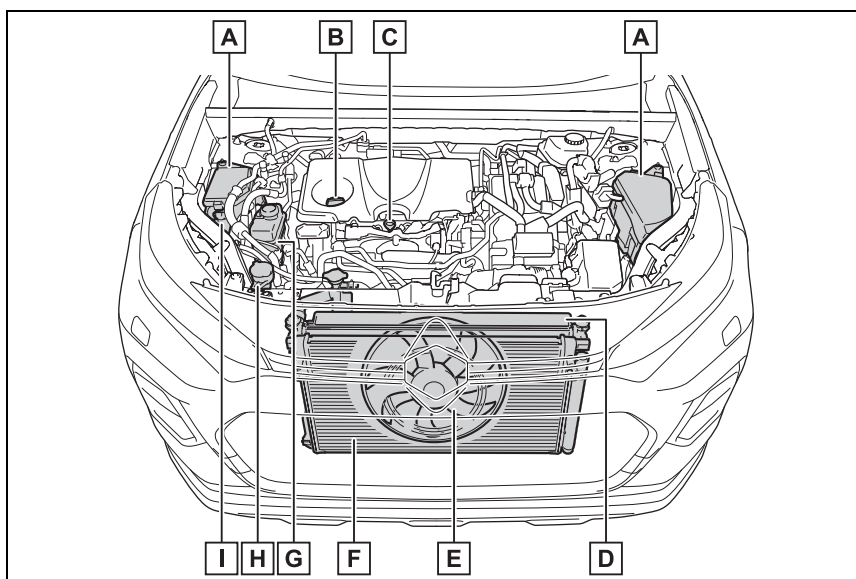

- A** Fuse boxes (→P.486)
- B** Engine oil filler cap (→P.446)
- C** Engine oil level dipstick (→P.445)
- D** Radiator (→P.448)
- E** Electric cooling fan
- F** Condenser (→P.448)
- G** Power control unit coolant reservoir (→P.448)
- H** Washer fluid tank (→P.449)
- I** Engine coolant reservoir (→P.447)

■ **12-volt battery**
→P.450

Checking and adding the engine oil

With the engine at operating temperature and turned off, check the

oil level on the dipstick.

■ **Checking the engine oil**

- 1 Park the vehicle on level ground. After warming up the engine and turning off the hybrid system, wait more than 5 minutes for the oil to drain back into the bottom of the engine.
- 2 Holding a rag under the end, pull the dipstick out.

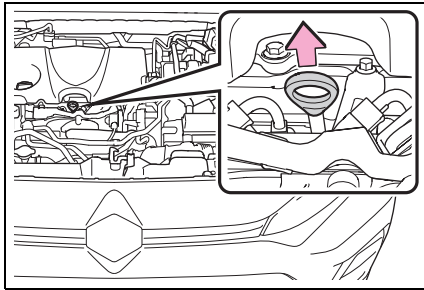

- 3 Wipe the dipstick clean.
- 4 Reinsert the dipstick fully.
- 5 Holding a rag under the end, pull the dipstick out and check the oil level.

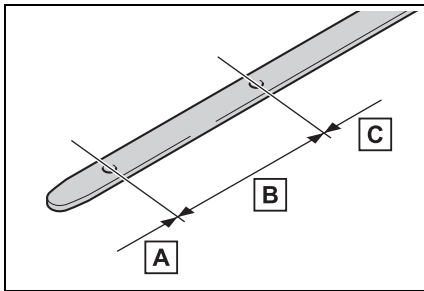

- A** Low
- B** Normal
- C** Excessive

The shape of the dipstick may differ

depending on the type of vehicle or engine.

- 6 Wipe the dipstick and reinsert it fully.

■ **Checking the oil type and preparing the items needed**

Make sure to check the oil type and prepare the items needed before adding oil.

- Engine oil selection

→P.549

- Oil quantity (Low → Full)

1.5 L (1.6 qt., 1.3 Imp. qt.)

- Item

Clean funnel

■ **Adding engine oil**

If the oil level is below or near the low level mark, add engine oil of the same type as that already in the engine.

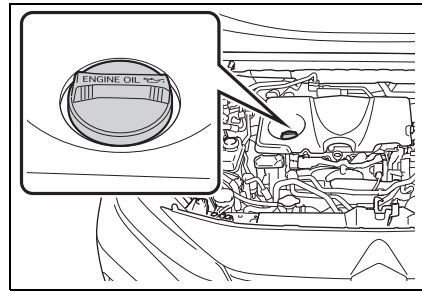

- 1 Remove the oil filler cap by turning it counterclockwise.
- 2 Add engine oil slowly, checking the dipstick.
- 3 Install the oil filler cap by turning it clockwise.

■ Engine oil consumption

A certain amount of engine oil will be consumed while driving. In the following situations, oil consumption may increase, and engine oil may need to be refilled in between oil maintenance intervals.

- When the engine is new, for example directly after purchasing the vehicle or after replacing the engine
- If low quality oil or oil of an inappropriate viscosity is used
- When driving at high engine speeds or with a heavy load, when towing, or when driving while accelerating or decelerating frequently
- When leaving the engine idling for a long time, or when driving frequently through heavy traffic



WARNING

■ Used engine oil

- Used engine oil contains potentially harmful contaminants which may cause skin disorders such as inflammation and skin cancer, so care should be taken to avoid prolonged and repeated contact. To remove used engine oil from your skin, wash thoroughly with soap and water.
- Dispose of used oil and filters only in a safe and acceptable manner. Do not dispose of used oil and filters in household trash, in sewers or onto the ground. Call a SUZUKI dealer or a qualified workshop, service station or auto parts store for information concerning recycling or disposal.
- Do not leave used engine oil within the reach of children.



NOTICE

■ To prevent serious engine damage

Check the oil level on a regular basis.

■ When replacing the engine oil

- Be careful not to spill engine oil on the vehicle components.
- Avoid overfilling, or the engine could be damaged.
- Check the oil level on the dipstick every time you refill the vehicle.
- Be sure the engine oil filler cap is properly tightened.

■ If oil is spilled on the engine cover

To prevent the engine cover from being damaged, remove any engine oil from the engine cover as soon as possible using a neutral detergent. Do not use an organic solvent such as brake cleaner.

Checking the coolant

The coolant level is satisfactory if it is between the “FULL” and “LOW” lines on the reservoir when the hybrid system is cold.

■ Engine coolant reservoir

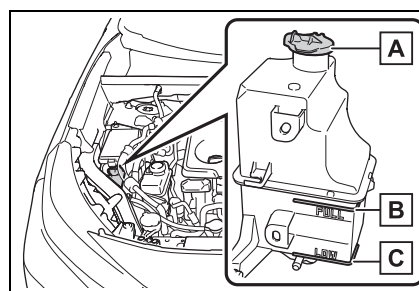

A Reservoir cap

B “FULL” line

C “LOW” line

If the level is on or below the “LOW” line, add coolant up to the “FULL” line. (→P.540)

■ **Power control unit coolant reservoir**

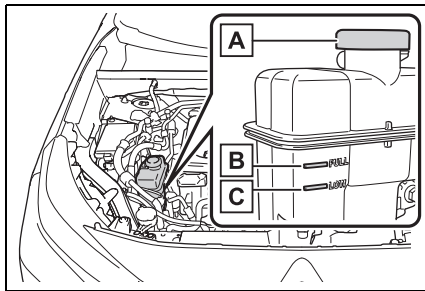

A Reservoir cap

B “FULL” line

C “LOW” line

If the level is on or below the “LOW” line, add coolant up to the “FULL” line. (→P.541)

■ **Coolant selection**

Only use “Toyota Super Long Life Coolant” or a similar high quality ethylene glycol based non-silicate, non-amine, non-nitrite, and non-borate coolant with long-life hybrid organic acid technology. “Toyota Super Long Life Coolant” is a mixture of 50% coolant and 50% deionized water. (Minimum temperature: -35°C [-31°F])

For more details about coolant, contact a SUZUKI dealer or a qualified workshop.

■ **If the coolant level drops within a short time of replenishing**

Visually check the radiators, hoses, engine/power control unit coolant reservoir caps, drain cock and water pump. If you cannot find a leak, have a SUZUKI dealer or a qualified workshop,

test the cap and check for leaks in the cooling system.

! WARNING

■ **When the hybrid system is hot**

Do not remove the engine/power control unit coolant reservoir caps.

The cooling system may be under pressure and may spray hot coolant if the cap is removed, causing serious injuries, such as burns.

! NOTICE

■ **When adding coolant**

Coolant is neither plain water nor straight antifreeze. The correct mixture of water and antifreeze must be used to provide proper lubrication, corrosion protection and cooling. Be sure to read the antifreeze or coolant label.

■ **If you spill coolant**

Be sure to wash it off with water to prevent it from damaging parts or paint.

Checking the radiator and condenser

Check the radiator and condenser, and clear away any foreign objects. If either of the above parts is extremely dirty or you are not sure of their condition, have your vehicle inspected by a SUZUKI dealer or a qualified workshop.

! WARNING

■ **When the hybrid system is hot**

Do not touch the radiator or condenser as they may be hot and cause serious injuries, such as burns.

⚠ WARNING**■ When the electric cooling fan is operating**

Do not touch the engine compartment.

With the power switch in ON mode, the electric cooling fan may automatically start to run if the air conditioning is on and/or the coolant temperature is high. Be sure the power switch is off when working near the electric cooling fan or radiator grille.

Checking and adding the washer fluid

Type A: If any washer does not work, the washer tank may be empty. Add washer fluid.

Type B: If any washer does not work or the warning message appears on the multi-information display, the washer tank may be empty. Add washer fluid.

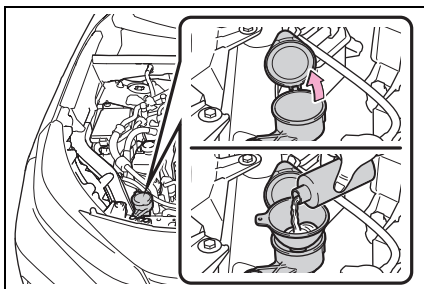
**⚠ WARNING****■ When adding washer fluid**

Do not add washer fluid when the hybrid system is hot or operating as washer fluid contains alcohol and may catch fire if spilled on the hybrid system, etc.

⚠ NOTICE**■ Do not use any fluid other than washer fluid**

Do not use soapy water or engine antifreeze instead of washer fluid. Doing so may cause streaking on the vehicle's painted surfaces, as well as damaging the pump leading to problems of the washer fluid not spraying.

■ Diluting washer fluid

Dilute washer fluid with water as necessary. Refer to the freezing temperatures listed on the label of the washer fluid bottle.

12-volt battery

Location

The 12-volt battery is located in the right-hand side of luggage compartment.

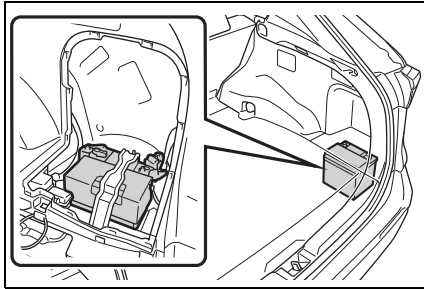

Before recharging

When recharging, the 12-volt battery produces hydrogen gas which is flammable and explosive. Therefore, observe the following precautions before recharging:

- If recharging with the 12-volt battery installed on the vehicle, be sure to disconnect the ground cable.
- Make sure the power switch on the charger is off when connecting and disconnecting the charger cables to the 12-volt battery.

After recharging/reconnecting the 12-volt battery

The hybrid system may not start. Follow the procedure below to initialize the system.

- 1 Shift the shift lever to P.
 - 2 Open and close any of the doors.
 - 3 Restart the hybrid system.
- Unlocking the doors using the smart entry & start system may not be possible immediately after reconnecting the 12-volt battery. If this happens, use the wireless remote control or the mechanical key to lock/unlock the

doors.

- Start the hybrid system with the power switch in ACC. The hybrid system may not start with the power switch turned off. However, the hybrid system will operate normally from the second attempt.
- The power switch mode is recorded by the vehicle. If the 12-volt battery is reconnected, the vehicle will return the power switch mode to the status it was in before the 12-volt battery was disconnected. Make sure to turn off the power switch before disconnecting the 12-volt battery. Take extra care when connecting the 12-volt battery if the power switch mode prior to discharge is unknown.

If the hybrid system will not start even after multiple attempts at all methods above, contact a SUZUKI dealer or a qualified workshop.

WARNING

Chemicals in the 12-volt battery

The 12-volt battery contains poisonous and corrosive sulfuric acid and may produce hydrogen gas which is flammable and explosive. To reduce the risk of death or serious injury, take the following precautions while working on or near the 12-volt battery:

- Do not cause sparks by touching the 12-volt battery terminals with tools.
- Do not smoke or light a match near the 12-volt battery.
- Avoid contact with eyes, skin and clothes.
- Never inhale or swallow electrolyte.
- Wear protective safety glasses when working near the 12-volt battery.
- Keep children away from the 12-volt battery.

⚠ WARNING**■ Where to safely charge the 12-volt battery**

Always charge the 12-volt battery in an open area. Do not charge the 12-volt battery in a garage or closed room where there is not sufficient ventilation.

■ Emergency measures regarding electrolyte**● If electrolyte gets in your eyes**

Flush your eyes with clean water for at least 15 minutes and get immediate medical attention. If possible, continue to apply water with a sponge or cloth while traveling to the nearest medical facility.

● If electrolyte gets on your skin

Wash the affected area thoroughly. If you feel pain or burning, get medical attention immediately.

● If electrolyte gets on your clothes

It can soak through clothing on to your skin. Immediately take off the clothing and follow the procedure above if necessary.

● If you accidentally swallow electrolyte

Drink a large quantity of water or milk. Get emergency medical attention immediately.

■ When there is insufficient 12-volt battery fluid

Do not use if there is insufficient fluid in the 12-volt battery. There is a possible danger that the 12-volt battery may explode.

⚠ NOTICE**■ When recharging the 12-volt battery**

Never recharge the 12-volt battery while the hybrid system is operating. Also, be sure all accessories are turned off.

Removing the 12-volt battery cover

- 1 Open the deck board (→P.424)
- 2 Disengage the 13 claws and pull the luggage side cover to remove it.

When installing the luggage side cover, make sure that the claws are installed securely.

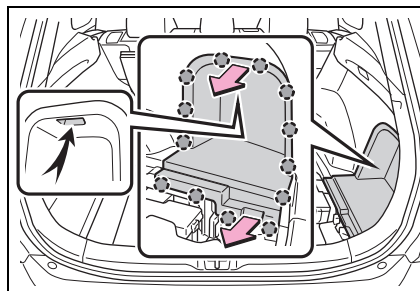
**Exterior**

Make sure that the 12-volt battery terminals are not corroded and that there are no loose connections, cracks, or loose clamps.

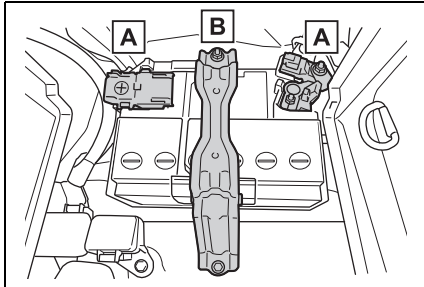

- A** Terminals
- B** Hold-down clamp

Checking the battery condition

Check the battery condition by indicator color.

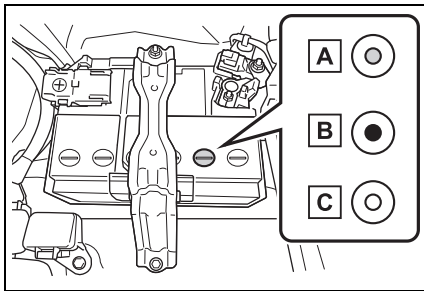

- A** Blue: Good condition
- B** Red: Charging is necessary.
Have the vehicle inspected by a SUZUKI dealer or a qualified workshop.
- C** Clear: Not working properly. Add distilled water or replace the battery.
Have the vehicle inspected by a SUZUKI dealer or a qualified workshop.

Tires

Replace or rotate tires in accordance with maintenance schedules and treadwear.

Checking tires

Check if the treadwear indicators are showing on the tires. Also check the tires for uneven wear, such as excessive wear on one side of the tread. Check the spare tire condition and pressure if not rotated.

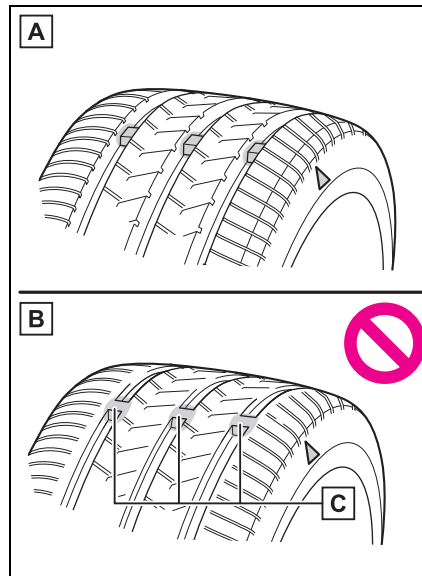

- A** New tread
- B** Worn tread
- C** Treadwear indicator

The location of treadwear indicators is shown by a "TWI" or "△" marks, etc.,

molded into the sidewall of each tire. Replace the tires if the treadwear indicators are showing on a tire.

■ When to replace your vehicle's tires

Tires should be replaced if:

- The treadwear indicators are showing on a tire.
- You have tire damage such as cuts, splits, cracks deep enough to expose the fabric, and bulges indicating internal damage.
- A tire goes flat repeatedly or cannot be properly repaired due to the size or location of a cut or other damage.

If you are not sure, consult with a SUZUKI dealer or a qualified workshop.

■ Tire life

Any tire over 6 years old must be checked by a qualified technician even if it has seldom or never been used or damage is not obvious.

■ If the tread on snow tires wears down below 4 mm (0.16 in.)

The effectiveness of the tires as snow tires is lost.

 **WARNING**

■ When inspecting or replacing tires

Observe the following precautions to prevent accidents. Failure to do so may cause damage to parts of the drive train as well as dangerous handling characteristics, which may lead to an accident resulting in death or serious injury.

- Do not mix tires of different makes, models or tread patterns. Also, do not mix tires of remarkably different treadwear.
- Do not use tire sizes other than those recommended by Suzuki.

- Do not mix differently constructed tires (radial, bias-belted or bias-ply tires).
- Do not mix summer, all season and snow tires.
- Do not use tires that have been used on another vehicle. Do not use tires if you do not know how they were used previously.
- Do not tow if your vehicle has a compact spare tire installed.

 **NOTICE**

■ Driving on rough roads

Take particular care when driving on roads with loose surfaces or potholes. These conditions may cause losses in tire inflation pressure, reducing the cushioning ability of the tires. In addition, driving on rough roads may cause damage to the tires themselves, as well as the vehicle's wheels and body.

■ If tire inflation pressure of each tire becomes low while driving

Do not continue driving, or your tires and/or wheels may be ruined.

Tire rotation

Rotate the tires in the order shown.

To equalize tire wear and help extend tire life, Suzuki recommends that tire rotation is carried out approximately every 5000 km (3000 miles).

Do not fail to initialize the tire pressure warning system after tire rotation.

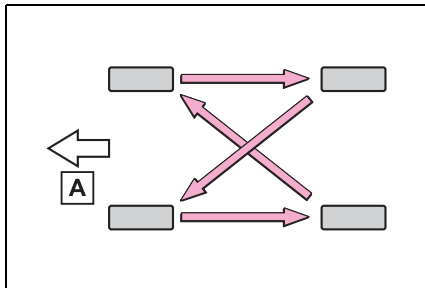

A Front

■ **When rotating the tires**

Make sure that the power switch is OFF. If the tires are rotated while the power switch is in ON, the tire position information will not be updated.

If this accidentally occurs, either turn the power switch to OFF and then to ON, or initialize the system after checking that the tire pressure is properly adjusted.

Tire pressure warning system

Your vehicle is equipped with a tire pressure warning system that uses tire pressure warning valves and transmitters to detect low tire inflation pressure before serious problems arise.

The tire pressure warning system of this vehicle adopts a 2-type warning system

- When “Adjust Pressure” is displayed (Normal Warning)

The tire pressure warning light comes on and a buzzer sounds when the tire inflation pressure becomes low due to natural air leakage or outside temperature. (Ways of coping: →P.515, 552)

- When “Immediately Check tire

when Safe” is displayed (Emergency Warning)

The tire pressure warning light comes on and a buzzer sounds when the tire inflation pressure becomes low suddenly due to a blowout. (Ways of coping: →P.515, 522)

However, the system may not be able to detect sudden tire ruptures (bursting, etc.).

The tire pressure detected by the tire pressure warning system can be displayed on the multi-information display.

The unit can be changed.

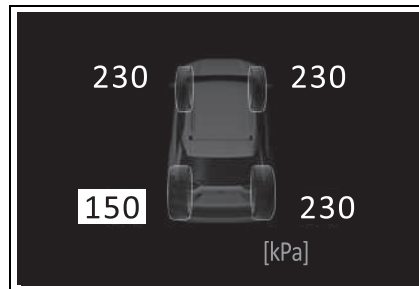

■ **How to change the unit**



- 1 Park the vehicle in a safe place and turn the power switch off.

Changing the unit cannot be performed while the vehicle is moving.

- 2 Turn the power switch to ON.

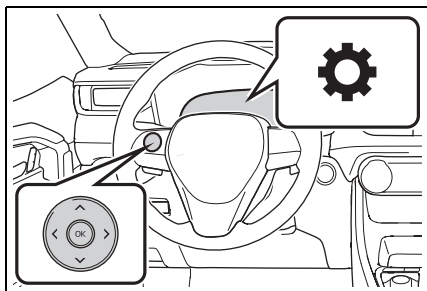
- 3 Press **<** or **>** of the meter control switches on the steering wheel and select .



- 4 Press **▲** or **▼** of the meter control switches and select “Vehicle Settings”, and then press and hold .
- 5 Press **▲** or **▼** of the meter control switches and select “TPWS”, and then press .
- 6 Press **▲** or **▼** to select “Setting Unit”.
- 7 Press **▲** or **▼** to select the desired unit and then press .

■ Routine tire inflation pressure checks

The tire pressure warning system does not replace routine tire inflation pressure checks. Make sure to check tire inflation pressure as part of your routine of daily vehicle checks.

■ Tire inflation pressure

- It may take a few minutes to display the tire inflation pressure after the power switch is turned to ON. It may also take a few minutes to display the tire inflation pressure after inflation pressure has been adjusted.

- Tire inflation pressure changes with temperature. The displayed values may also be different from the values measured using a tire pressure gauge.

■ Situations in which the tire pressure warning system may not operate properly

- In the following cases, the tire pressure warning system may not operate properly.
 - If non-genuine Suzuki wheels are used.
 - A tire has been replaced with a tire that is not an OE (Original Equipment) tire.
 - A tire has been replaced with a tire that is not of the specified size.
 - An auxiliary-supported run-flat tire is equipped.
 - If a window tint that affects the radio wave signals is installed.
 - If there is a lot of snow or ice on the vehicle, particularly around the wheels or wheel housings.
 - If the tire inflation pressure is extremely higher than the specified level.
 - If wheels without tire pressure warning valves and transmitters are used.
 - If the ID code on the tire pressure warning valves and transmitters is not registered in the tire pressure warning computer.
- Performance may be affected in the following situations.
 - Near a TV tower, electric power plant, gas station, radio station, large display, airport or other facility that generates strong radio waves or electrical noise
 - When carrying a portable radio, cellular phone, cordless phone or other wireless communication device
If tire position information is not correctly displayed due to the radio wave conditions, the display may be corrected by driving and changing the radio wave conditions.
- When the vehicle is parked, the time taken for the warning to start or go off

could be extended.

- When tire inflation pressure declines rapidly for example when a tire has burst, the warning may not function.

■ **Warning performance of the tire pressure warning system**

The warning of the tire pressure warning

system will change in accordance with the conditions under which it was initialized. For this reason, the system may give a warning even if the tire pressure does not reach a low enough level, or if the pressure is higher than the pressure that was adjusted to when the system was initialized.

■ **Certification for tire pressure warning system**

▪ Manufacturer's name: PACIFIC INDUSTRIAL CO.,LTD.

▪ Registered trademark: 

This trademark is registered in the following countries:
UK, Italy, Austria, Greece, Germany, France, Belgium,
the Netherlands, Luxembourg, Portugal.

▪ Manufacturer's address:

1300-1 Yokoi, Godo-cho, Anpachi-gun, Gifu, 503-2397 JAPAN

▪ Operating frequency band: 433.05 — 434.79MHz

▪ Maximum radio-frequency power: 100dB μ V/m@3m(Radiated)

Hereby, PACIFIC INDUSTRIAL CO.,LTD. declares that the radio equipment type PMV-E100 is in compliance with Directive 2014/53/EU.

The full text of the EU declaration of conformity is available at the following internet address:

<http://www.pacific-ind.co.jp/eng/products/car/tpms/doc/>

PACIFIC INDUSTRIAL CO.,LTD. vakuuttaa, että radiolaitetyyppi PMV-E100 on direktiivin 2014/53/EU mukainen.

EU-vaatimustenmukaisuusvakuutuksen täysimittainen teksti on saatavilla seuraavassa internetosoitteessa:

<http://www.pacific-ind.co.jp/eng/products/car/tpms/doc/>

Hierbij verklaar ik, PACIFIC INDUSTRIAL CO.,LTD., dat het type radioapparatuur PMV-E100 conform is met Richtlijn 2014/53/EU.

De volledige tekst van de EU-conformiteitsverklaring kan worden geraadpleegd op het volgende internetadres:

<http://www.pacific-ind.co.jp/eng/products/car/tpms/doc/>

Le soussigné, PACIFIC INDUSTRIAL CO.,LTD., déclare que l'équipement radioélectrique du type PMV-E100 est conforme à la directive 2014/53/UE.

Le texte complet de la déclaration UE de conformité est disponible à l'adresse internet suivante:

<http://www.pacific-ind.co.jp/eng/products/car/tpms/doc/>

Härmed försäkrar PACIFIC INDUSTRIAL CO.,LTD. att denna typ av radioutrustning PMV-E100 överensstämmer med direktiv 2014/53/EU.

Den fullständiga texten till EU-försäkran om överensstämmelse finns på följande webbadress:

<http://www.pacific-ind.co.jp/eng/products/car/tpms/doc/>

Hermed erklærer PACIFIC INDUSTRIAL CO.,LTD., at radioudstyrstypen PMV-E100 er i

overensstemmelse med direktiv 2014/53/EU.

EU-overensstemmelseserklæringens fulde tekst kan findes på følgende internetadresse:

<http://www.pacific-ind.co.jp/eng/products/car/tpms/doc/>

Hiermit erklährt PACIFIC INDUSTRIAL CO.,LTD. , dass der Funkanlagentyp PMV-E100 der Richtlinie 2014/53/EU entspricht.

Der vollständige Text der EU-Konformitätserklärung ist unter der folgenden Internetadresse verfügbar:

<http://www.pacific-ind.co.jp/eng/products/car/tpms/doc/>

Με την παρούσα ο/η PACIFIC INDUSTRIAL CO.,LTD., δηλώνει ότι ο ραδιοεξοπλισμός PMV-E100 πληροί την οδηγία 2014/53/ΕΕ. Το πλήρες κείμενο της δήλωσης συμμόρφωσης ΕΕ διατίθεται στην ακόλουθη ιστοσελίδα στο διαδίκτυο:

<http://www.pacific-ind.co.jp/eng/products/car/tpms/doc/>

Il fabbricante, PACIFIC INDUSTRIAL CO.,LTD. , dichiara che il tipo di apparecchiatura radio PMV-E100 è conforme alla direttiva 2014/53/UE.

Il testo completo della dichiarazione di conformità UE è disponibile al seguente indirizzo Internet:

<http://www.pacific-ind.co.jp/eng/products/car/tpms/doc/>

Por la presente, PACIFIC INDUSTRIAL CO.,LTD.declara que el tipo de equipo radioeléctrico PMV-E100 es conforme con la Directiva 2014/53/UE.

El texto completo de la declaración UE de conformidad está disponible en la dirección Internet siguiente:

<http://www.pacific-ind.co.jp/eng/products/car/tpms/doc/>

O(a) abaixo assinado(a) PACIFIC INDUSTRIAL CO.,LTD. declara que o presente tipo de equipamento de rádio PMV-E100 está em conformidade com a Diretiva 2014/53/UE.

O texto integral da declaração de conformidade está disponível no seguinte endereço de Internet:

<http://www.pacific-ind.co.jp/eng/products/car/tpms/doc/>

B'dan, PACIFIC INDUSTRIAL CO.,LTD., niddikjara li dan it-tip ta' tagħmir tar-radju PMV-E100 huwa konformi mad-Direttiva 2014/53/UE.

It-test kollu tad-dikjarazzjoni ta' konformità tal-UE huwa disponibbli f'dan l-indirizz tal-Internet li ġej:

<http://www.pacific-ind.co.jp/eng/products/car/tpms/doc/>

Käesolevaga deklareerib PACIFIC INDUSTRIAL CO.,LTD., et käesolev raadioseadme tüüp PMV-E100 vastab direktiivi 2014/53/EL nõuetele.

ELi vastavusdeklaratsiooni täielik tekst on kättesaadav järgmisel internetiaadressil:

<http://www.pacific-ind.co.jp/eng/products/car/tpms/doc/>

PACIFIC INDUSTRIAL CO.,LTD. igazolja, hogy a PMV-E100 típusú rádióberendezés megfelel a 2014/53/EU irányelvnek.

Az EU-megfelelőségi nyilatkozat teljes szövege elérhető a következő internetes címen:

<http://www.pacific-ind.co.jp/eng/products/car/tpms/doc/>

PACIFIC INDUSTRIAL CO.,LTD. týmto vyhlasuje, že rádiové zariadenie typu PMV-E100 je v súlade so smernicou 2014/53/EÚ.

Úplné EÚ vyhlásenie o zhode je k dispozícii na tejto internetovej adrese:

<http://www.pacific-ind.co.jp/eng/products/car/tpms/doc/>

Tímto PACIFIC INDUSTRIAL CO.,LTD. prohlašuje, že typ rá
diového zařízení PMV-E100 je v souladu
se směrnicí 2014/53/EU.

Úplné znění EU prohlášení o shodě je k dispozici na této
internetové adrese:

<http://www.pacific-ind.co.jp/eng/products/car/tpms/doc/>

PACIFIC INDUSTRIAL CO.,LTD. potvrjuje, da je tip radijske
opreme PMV-E100 skladen z Direktivo
2014/53/EU.

Celotno besedilo izjave EU o skladnosti je na voljo na
naslednjem spletnem naslovu:

<http://www.pacific-ind.co.jp/eng/products/car/tpms/doc/>

Aš, PACIFIC INDUSTRIAL CO.,LTD. , patvirtinu, kad radijo i
renginių tipas PMV-E100 atitinka Direktyvą 2014/53/ES.

Visas ES atitikties deklaracijos tekstas prieinamas šiuo
internetu adresu:

<http://www.pacific-ind.co.jp/eng/products/car/tpms/doc/>

Ar šoPACIFIC INDUSTRIAL CO.,LTD. deklarē, ka radioiekārta
PMV-E100 atbilst Direktīvai
2014/53/ES.

Pilns ES atbilstības deklarācijas teksts ir pieejams šādā
interneta vietnē:

<http://www.pacific-ind.co.jp/eng/products/car/tpms/doc/>

PACIFIC INDUSTRIAL CO.,LTD. niniejszym oświadcza, że typ urządzenia radiowego PMV-E100 jest zgodny z dyrektywą 2014/53/UE.

Pełny tekst deklaracji zgodności UE jest dostępny pod następującym adresem internetowym:

<http://www.pacific-ind.co.jp/eng/products/car/tpms/doc/>

Hér með lýsir PACIFIC INDUSTRIAL CO.,LTD. yfir því að PMV-E100 er í samræmi við grunnkröfur og aðrar kröfur, sem gerðar eru í tilskipun 2014/53/EU.

Samræmisýfirlýsing er einnig aðgengileg á eftirfarandi vefslóð:

<http://www.pacific-ind.co.jp/eng/products/car/tpms/doc/>

PACIFIC INDUSTRIAL CO.,LTD. erklærer at PMV-E100 er i overensstemmelse med direktiv 2014/53/EU.

Samsvarserklæringen i fulltekst er tilgjengelig på følgende internettadresse:

<http://www.pacific-ind.co.jp/eng/products/car/tpms/doc/>

С настоящото PACIFIC INDUSTRIAL CO.,LTD. декларира, че този тип радиосъоръжение PMV-E100 е в съответствие с Директива 2014/53/ЕС.

Цялостният текст на ЕС декларацията за съответствие може да се намери на следния интернет адрес:
<http://www.pacific-ind.co.jp/eng/products/car/tpms/doc/>

Prin prezenta, PACIFIC INDUSTRIAL CO.,LTD. declară că tipul de echipamente radio PMV-E100 este în conformitate cu Directiva 2014/53/UE.

Textul integral al declarației UE de conformitate este disponibil la următoarea adresă internet:

<http://www.pacific-ind.co.jp/eng/products/car/tpms/doc/>

Ovim, PACIFIC INDUSTRIAL CO.,LTD. , izjavljuje da ovaj PMV-E100 je usklađen sa bitnim zahtjevima i drugim relevantnim odredbama Direktive 1999/5/EC.

<http://www.pacific-ind.co.jp/eng/products/car/tpms/doc/>

Ovim, PACIFIC INDUSTRIAL CO.,LTD., deklariše da je PMV-E100 u skladu sa osnovnim zahtevima i ostalim relevantnim odredbama Direktive 1999/5/EC.
<http://www.pacific-ind.co.jp/eng/products/car/tpms/doc/>

PACIFIC INDUSTRIAL CO.,LTD. ovime izjavljuje da je radijska oprema tipa PMV-E100 u skladu s Direktivom 2014/53/EU.
 Cjeloviti tekst EU izjave o sukladnosti dostupan je na sljedećoj internetskoj adresi:
<http://www.pacific-ind.co.jp/eng/products/car/tpms/doc/>

Nepermjet kesaj, PACIFIC INDUSTRIAL CO.,LTD. , deklaroj qe ky PMV-E100 eshte ne pajtim me kerkesat thelbesore dhe dispozitat e tjera perkatese te Direktives 1999/5/EC.
<http://www.pacific-ind.co.jp/eng/products/car/tpms/doc/>

Installing tire pressure warning valves and transmitters

When replacing tires or wheels, tire pressure warning valves and transmitters must also be installed.

When new tire pressure warning valves and transmitters are installed, new ID codes must be registered in the tire pressure warning computer and the tire pressure warning system must be initialized. (→P.467)

When replacing the tires and wheels

If the ID code of the tire pressure warning valve and transmitter is not registered, the tire pressure warning system will not work properly. After driving for

about 10 minutes, the tire pressure warning light blinks for 1 minute and stays on to indicate a system malfunction.

 NOTICE

- **Repairing or replacing tires, wheels, tire pressure warning valves, transmitters and tire valve caps**
- When removing or fitting the wheels, tires or the tire pressure warning valves and transmitters, contact a SUZUKI dealer or a qualified workshop as the tire pressure warning valves and transmitters may be damaged if not handled correctly.

 NOTICE

- Make sure to install the tire valve caps. If the tire valve caps are not installed, water could enter the tire pressure warning valves and the tire pressure warning valves could be bound.
- When replacing tire valve caps, do not use tire valve caps other than those specified. The cap may become stuck.

Initializing the tire pressure warning system**■ The tire pressure warning system must be initialized in the following circumstances:**

- When rotating the tires.
- When changing the tire.
- After registering the ID codes. (→P.467)
- When changing between two registered wheel sets.

When the tire pressure warning system is initialized, the current tire inflation pressure is set as the benchmark pressure.

■ How to initialize the tire pressure warning system



- 1** Park the vehicle in a safe place and stop the hybrid system for 20 minutes or more.

Initialization cannot be performed while the vehicle is moving.







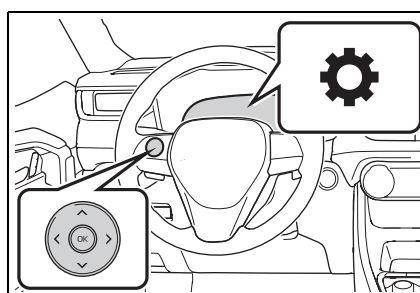

- 2** Adjust the tire inflation pressure to the specified cold tire inflation pressure level. (→P.552)

Make sure to adjust the tire pressure to

the specified cold tire inflation pressure level. The tire pressure warning system will operate based on this pressure level.

- 3** Start the hybrid system.
- 4** Press  or  of the meter control switches on the steering wheel and select .



- 5** Press  or  of the meter control switches, select "Vehicle Settings" and then press and hold .
- 6** Press  or  of the meter control switches, select "TPWS" and then press .
- 7** Press  or  of the meter control switches, select the "Setting Pressure". Then press and hold .

"Set Pressure Accepted" will be displayed on the multi-information display and the tire pressure warning light will blink 3 times.

When the message disappears, initialization is complete.

A message is displayed on the multi-information display. Also, "--" is displayed for inflation pressure of each tire on the multi-information display while the tire pressure warning system deter-

mines the position.

- 8 Drive straight (with occasional left and right turns) at approximately 40 km/h (25mph) or more for approximately 10 to 30 minutes.

When initialization is complete, the inflation pressure of each tire will be displayed on the multi-information display.

Even if the vehicle is not driven at approximately 40 km/h (25 mph) or more, initialization can be completed by driving for a long time. However, if initialization does not complete after driving for 1 hour or more, park the vehicle in a safe place for approximately 20 minutes and then drive the vehicle again.

■ When initializing

- Initialization is performed while driving at a vehicle speed of approximately 40 km/h (25 mph) or more.
- Make sure to carry out initialization after adjusting the tire inflation pressure. Also, make sure the tires are cold before carrying out initialization or tire inflation pressure adjustment.
- The tire pressure warning system can be initialized by yourself, but depending on the driving conditions and driving environment, initialization may take some time to complete.

■ The initialization operation

- If you have accidentally turned the power switch to OFF during initialization, it is not necessary to restart the initialization again as initialization will restart automatically when the power switch has been turned to ON for the next time.
- If you accidentally perform initialization when initialization is not necessary, adjust the tire inflation pressure to the specified level when the tires are cold, and conduct initialization

again.

- While the position of each tire is being determined and the inflation pressures are not being displayed on the multi-information display, if the inflation pressure of a tire drops, the tire pressure warning light will come on.

■ If the tire pressure warning system is not initialized properly

- In the following situations, initialization may take longer than usual to be completed or may not be possible. Normally, initialization completes within approximately 30 minutes.
 - Vehicle is not driven at approximately 40 km/h (25 mph) or more
 - Vehicle is driven on unpaved roads
 - Vehicle is driven near other vehicles and system cannot recognize tire pressure warning valve and transmitters of your vehicle over those of other vehicles.
 - If the vehicle is driven in heavy traffic or another situation where other vehicles are driven close by, it may take time for the system to recognize the tire pressure warning valve and transmitters of your vehicle over those of other vehicles.
- If initialization does not complete after driving for 1 hour or more, park the vehicle in a safe place for approximately 20 minutes and then drive the vehicle again.
- If the vehicle is reversed during initialization, the data up to that point is reset, so perform the initialization procedure again from the beginning.
- In the following situations, initialization will not be started or was not completed properly and the system will not operate properly. Perform the initialization procedure again.
 - If, when attempting to start initialization, the tire pressure warning light does not blink 3 times.
 - If, when the vehicle has been driven for about 20 minutes after performing initialization, the tire pressure warning light blinks for approximately 1 minute

and then illuminates.

If initialization cannot be completed after performing the above procedure, contact a SUZUKI dealer or a qualified workshop.

WARNING

■ **When initializing the tire pressure warning system**



Do not initialize tire inflation pressure without first adjusting the tire inflation pressure to the specified level. Otherwise, the tire pressure warning light may not come on even if the tire inflation pressure is low, or it may come on when the tire inflation pressure is actually normal.

Registering ID codes







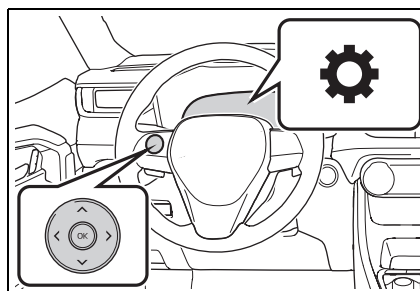

Every tire pressure warning valve and transmitter has a unique ID code. When replacing a tire pressure warning valve and transmitter, it is necessary to register the ID code.

When registering the ID codes, perform the following procedure.

- 1 Park the vehicle in a safe place, wait for approximately 20 minutes, and then start the hybrid system.

- 2 Press  or  of the meter control switches on the steering wheel and select .



- 3 Press  or  of the meter control switches and select "Vehicle Settings", and then press and hold .
- 4 Press  or  of the meter control switches and select "TPWS", and then press .
- 5 Press  or  of the meter control switches and select "Identifying Each Wheel & Position". Then press and hold  until the tire pressure warning light starts slowly blinking 3 times.

The change wheel set mode is activated and registration is started.

Then a message will be displayed on the multi-information display.

When registration is being performed, the tire pressure warning light will blink for approximately 1 minute then illuminate and "--" will be displayed for the inflation pressure of each tire on the multi-information display.

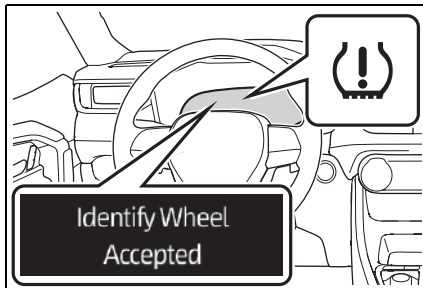

- 6 Drive straight (with occasional left and right turns) at approximately 40 km/h (25mph) or more for approximately 10 to 30 minutes.

When registration is completed, the tire pressure warning light will go off and the inflation pressure of each tire will be displayed on the multi-information display.

Even if the vehicle is not driven at approximately 40 km/h (25 mph) or more, registration can be completed by driving for a long time. However, if registration does not complete after driving for 1 hour or more, perform the procedure again from the beginning.

- 7 Initialize the tire pressure warning system. (→P.465)

■ When registering ID codes

- ID code registration is performed while driving at a vehicle speed of approximately 40 km/h (25 mph) or more.
- Before performing ID code registration, make sure that no wheels with tire pressure warning valve and transmitters installed are near the vehicle.
- Make sure to initialize the tire pressure warning system after registering the ID codes. If the system is initialized before registering the ID codes, the initialized values will be invalid.

- ID codes can be registered by yourself, but depending on the driving conditions and driving environment, registration may take some time to complete.

- As the tires will be warm when registration is completed, make sure to allow the tires to cool before performing initialization.

■ Canceling ID code registration

- To cancel ID code registration after it has been started, select "Identifying Each Wheel & Position" on the multi-information display and press and hold **OK** again.

- If ID code registration has been canceled, the tire pressure warning light will blink for approximately 1 minute when the power switch is turned to ON and then illuminate. The tire pressure warning system will be operational when the tire pressure warning light turns off.

- If the warning light does not turn off even after several minutes have elapsed, ID code registration may not have been canceled correctly. To cancel registration, perform the ID code registration start procedure again and then turn the power switch off before driving.

■ If ID codes are not registered properly

- In the following situations, ID code registration may take longer than usual to be completed or may not be possible. Normally, registration completes within approximately 30 minutes.
 - If ID code registration is not complete after driving for approximately 30 minutes, continue driving for a while.
 - Vehicle is not parked for approximately 20 minutes or more before driving
 - Vehicle is not driven at approximately 40 km/h (25 mph) or more
 - Vehicle is driven on unpaved roads
 - Vehicle is driven near other vehicles and system cannot recognize tire pressure warning valve and transmit-

ters of your vehicle over those of other vehicles

- Wheel with tire pressure warning valve and transmitter installed is inside or near the vehicle

If registration does not complete after driving for 1 hour or more, perform the ID code registration procedure again from the beginning.

- If the vehicle is reversed during registration, the data up to that point is reset, so perform the registration procedure again from the beginning.
- In the following situations, ID code registration will not be started or was not completed properly and the system will not operate properly. Perform the ID code registration procedure again.
 - If, when attempting to start ID code registration, the tire pressure warning light does not blink slowly 3 times.
 - If, when the vehicle has been driven for about 10 minutes after performing ID code registration, the tire pressure warning light blinks for approximately 1 minute and then illuminates.
- If ID code registration cannot be completed after performing the above procedure, contact a SUZUKI dealer or a qualified workshop.

Selecting wheel set

Your vehicle is equipped with tire pressure warning system with the function to have ID codes registered for a second wheel set, for example a winter set. You can register a second wheel set by yourself, a SUZUKI dealer or a qualified workshop.

After registration of a second wheel set, either of these two wheel sets can be selected for usage with the

tire pressure warning system.

■ Operating conditions for the function





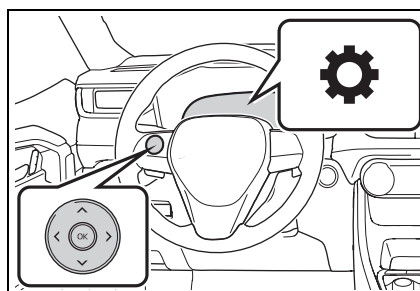

- This function will perform the change of wheel set only if a second wheel set has been registered. If no second wheel set has been registered, no change will be made when selecting this function in the menu.
- Only a change between both registered wheel set is possible, mixing between these wheel sets is not supported.

■ How to change between wheel sets

- 1 Have the vehicle fitted with the preferred wheel set.
- 2 Press **<** or **>** of the meter control switches on the steering wheel and select .



- 3 Press **▲** or **▼** of the meter control switches and select "Vehicle Settings", and then press and hold .

- 4 Press  or  of the meter control switches and select “TPWS”, and then press .
- 5 Press  or  of the meter control switches and select “Identifying Each Wheel & Position”. Then press and hold  until the tire pressure warning light starts slowly blinking 3 times.

complete when the tire pressure warning light turns off and the inflation pressure of each tire is displayed on the multi-information display.

Afterward, the tire pressure warning light turns on after flashing for 1 minute.

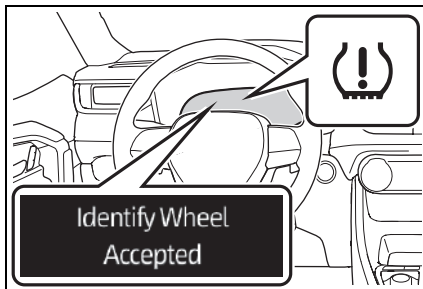

After 2 minutes, registration of a second wheel set is being performed. The tire pressure warning light will turn off and “...” will be displayed for the inflation pressure of each tire on the multi-information display.

- 6 Initialize the tire pressure warning system. (→P.464)

If the tire inflation pressure settings for the installed tires change, initialization operations are required, but if the tire inflation pressure settings are the same, initialization is not required.

- 7 Drive straight (with occasional left and right turns) at approximately 40 km/h (25 mph) or more for approximately 10 to 30 minutes.

Registration of a second wheel set is

Tire inflation pressure

Make sure to maintain the proper tire inflation pressure. Tire inflation pressure should be checked at least once per month. However, Suzuki recommends that tire inflation pressure be checked once every two weeks. (→P.552)

■ **Effects of incorrect tire inflation pressure**

Driving with incorrect tire inflation pressure may result in the following:

- Reduced fuel economy
- Reduced driving comfort and poor handling
- Reduced tire life due to wear
- Reduced safety
- Damage to the drive train

If a tire needs frequent inflating, have it checked by a SUZUKI dealer or a qualified workshop.

■ **Instructions for checking tire inflation pressure**

When checking tire inflation pressure, observe the following:

- Check only when the tires are cold. If your vehicle has been parked for at least 3 hours or has not been driven for more than 1.5 km or 1 mile, you will get an accurate cold tire inflation pressure reading.
- Always use a tire pressure gauge. It is difficult to judge if a tire is properly inflated based only on its appearance.
- It is normal for the tire inflation pressure to be higher after driving as heat is generated in the tire. Do not reduce tire inflation pressure after driving.
- Passengers and luggage weight should be placed so that the vehicle is

balanced.

 **WARNING**

■ **Proper inflation is critical to save tire performance**

Keep your tires properly inflated. If the tires are not properly inflated, the following conditions may occur which could lead to an accident resulting in death or serious injury:

- Excessive wear
- Uneven wear
- Poor handling
- Possibility of blowouts resulting from overheated tires
- Air leaking from between tire and wheel
- Wheel deformation and/or tire damage
- Greater possibility of tire damage while driving (due to road hazards, expansion joints, sharp edges in the road, etc.)

 **NOTICE**

■ **When inspecting and adjusting tire inflation pressure**

Be sure to put the tire valve caps back on.

If a valve cap is not installed, dirt or moisture may get into the valve and cause an air leak, resulting in decreased tire inflation pressure.

Wheels

If a wheel is bent, cracked or heavily corroded, it should be replaced. Otherwise, the tire may separate from the wheel or cause a loss of handling control.

Wheel selection

When replacing wheels, care should be taken to ensure that they are equivalent to those removed in load capacity, diameter, rim width and inset*.

Replacement wheels are available at a SUZUKI dealer or a qualified workshop.

*: Conventionally referred to as offset.

Suzuki does not recommend using the following:

- Wheels of different sizes or types
- Used wheels
- Bent wheels that have been straightened

■ When replacing wheels

The wheels of your vehicle are equipped with tire pressure warning valves and transmitters that allow the tire pressure warning system to provide advance warning in the event of a loss in tire inflation pressure. Whenever wheels are replaced, tire pressure warning valves and transmitters must be installed. (→P.454, 473)



WARNING

■ When replacing wheels

- Do not use wheels that are a different size from those recommended in the Owner's Manual, as this may result in a loss of handling control.
- Never use an inner tube in a leaking wheel which is designed for a tubeless tire. Doing so may result in an accident, causing death or serious injury.

■ When installing the wheel nuts

- Be sure to install the wheel nuts with the tapered ends facing inward. (→P.526) Installing the nuts with the tapered ends facing outward can cause the wheel to break and eventually cause the wheel to come off while driving, which could lead to an accident resulting in death or serious injury.
- Never use oil or grease on the wheel bolts or wheel nuts. Oil and grease may cause the wheel nuts to be excessively tightened, leading to bolt or disc wheel damage. In addition, the oil or grease can cause the wheel nuts to loosen and the wheel may fall off, causing an accident and resulting in death or serious injury. Remove any oil or grease from the wheel bolts or wheel nuts.

■ Use of defective wheels prohibited

Do not use cracked or deformed wheels.

Doing so could cause the tire to leak air during driving, possibly causing an accident.

 NOTICE**■ Replacing tire pressure warning valves and transmitters**

- Because tire repair or replacement may affect the tire pressure warning valves and transmitters, make sure to have tires serviced by a SUZUKI dealer or a qualified workshop or other qualified service shop. In addition, make sure to purchase your tire pressure warning valves and transmitters at a SUZUKI dealer or a qualified workshop.
- Ensure that only genuine Suzuki wheels are used on your vehicle. Tire pressure warning valves and transmitters may not work properly with non-genuine wheels.

Aluminum wheel precautions

- Use only Suzuki wheel nuts and wrenches designed for use with your aluminum wheels.
- When rotating, repairing or changing your tires, check that the wheel nuts are still tight after driving 1600 km (1000 miles).
- Use only Suzuki genuine balance weights or equivalent and a plastic or rubber hammer when balancing your wheels.

Air conditioning filter

The air conditioning filter must be changed regularly to maintain air conditioning efficiency.

Removal method

▶ Left-hand drive vehicles

- 1** Turn the power switch off.

Confirm that the charging connector is not connected. Also, do not use the Remote Air Conditioning System during the procedure.

- 2** Open the front passenger's door.

By keeping the door open, unexpected operation of the Remote Air Conditioning System can be prevented. (→P.413)

- 3** Open the glove box and slide off the damper.

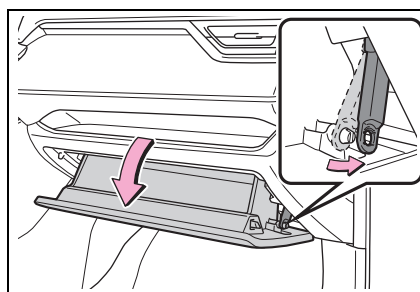

- 4** Push in each side of the glove box to disconnect the claws, and

then slowly and fully open the glove box while supporting it.

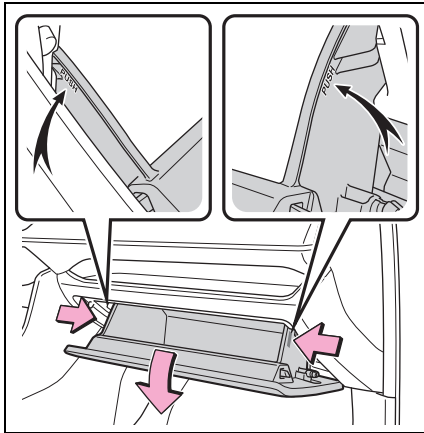

- 5** With the glove box fully open, slightly lift up the glove box and pull toward the seat to detach the bottom of the glove box.

Do not use excessive force if the glove box does not detach when lightly pulled. Instead, pull toward the seat while slightly adjusting the height of the glove box.

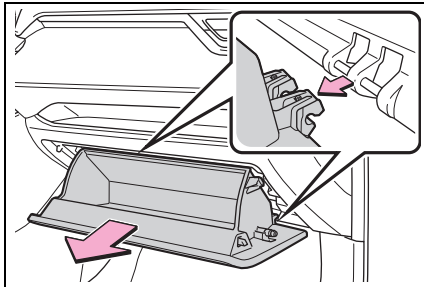

- 6** Unlock the filter cover (A), pull the filter cover out of the claws

(B), and remove the filter cover.

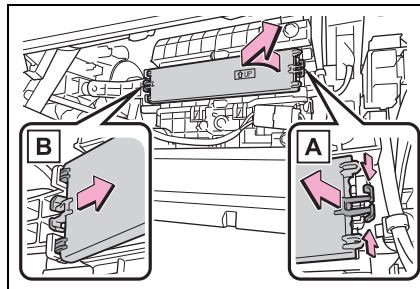

- 7** Remove the filter case.

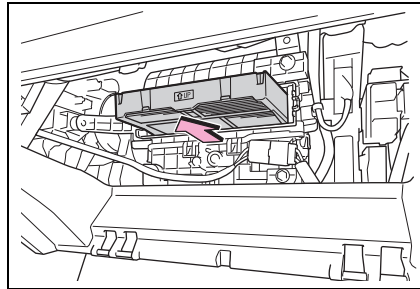

- 8** Remove the air conditioning filter from the filter case and replace it with a new one.

The “↑ UP” marks shown on the filter should be pointing up.

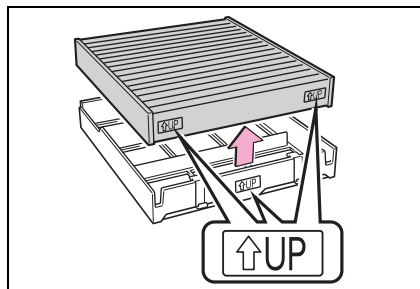

- 9** When installing, reverse the steps listed.

► Right-hand drive vehicles

- 1** Turn the power switch off.

Confirm that the charging connector is not connected. Also, do not use the Remote Air Conditioning System during the procedure.

- 2 Open the front passenger's door.

By keeping the door open, unexpected operation of the Remote Air Conditioning System can be prevented. (→P.413)

- 3 Open the glove box and slide off the damper.

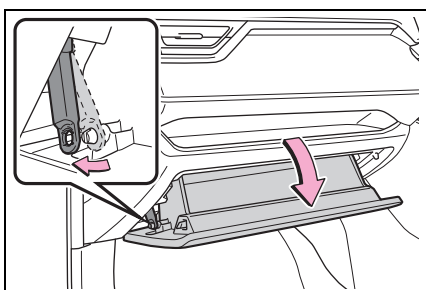

- 4 Push in each side of the glove box to disconnect the claws, and then slowly and fully open the glove box while supporting it.

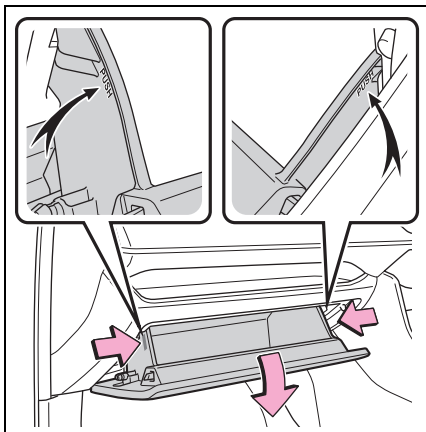

- 5 With the glove box fully open, slightly lift up the glove box and

pull toward the seat to detach the bottom of the glove box.

Do not use excessive force if the glove box does not detach when lightly pulled. Instead, pull toward the seat while slightly adjusting the height of the glove box.

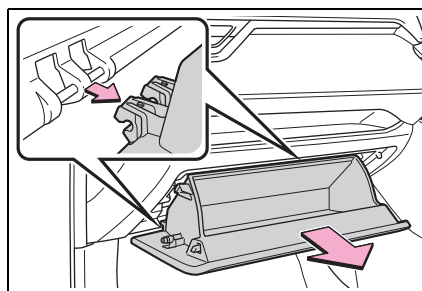

- 6 Unlock the filter cover (A), pull the filter cover out of the claws (B), and remove the filter cover.

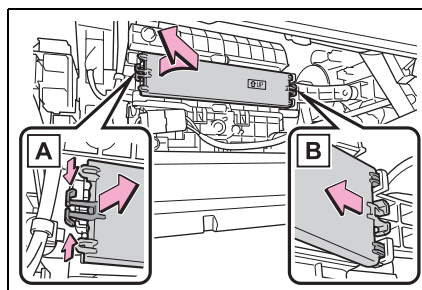

- 7 Remove the filter case.

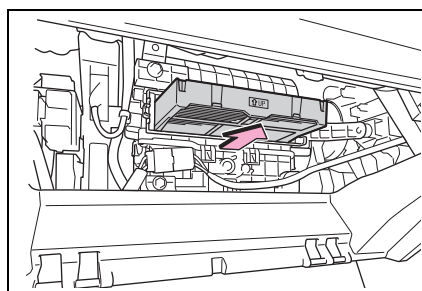

- 8 Remove the air conditioning filter and replace it with a new one.

The “↑ UP” marks shown on the filter should be pointing up.

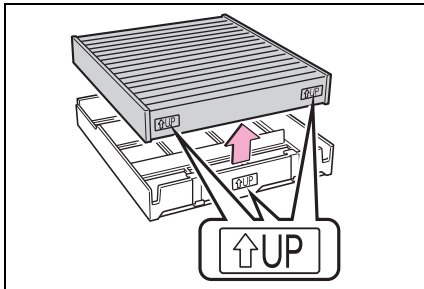

- 9 When installing, reverse the steps listed.

■ **Checking interval**

Inspect and replace the air conditioning filter according to the maintenance schedule. In dusty areas or areas with heavy traffic flow, early replacement may be required. (For scheduled maintenance information, please refer to the “Warranty and service record booklet”.)

■ **If air flow from the vents decreases dramatically**

The filter may be clogged. Check the filter and replace if necessary.

! WARNING

■ **When replacing the air conditioning filter**

Observe the following precautions. Failure to do so may result in the air conditioning system operating during the procedure, possibly resulting in injury.

- Check that the charging connector is not connected

Check that the charging connector is not connected

The air conditioning may operate due to the “Climate Prep” (→P.136) setting.

- Do not use the Remote Air Conditioning System

! NOTICE

■ **When using the air conditioning system**

Make sure that a filter is always installed.

Using the air conditioning system without a filter may cause damage to the system.

■ **When removing the glove box**

Always follow the specified procedure to remove the glove box (→P.473). If the glove box is removed without following the specified procedure, the hinge of the glove box may become damaged.

■ **To prevent damage to the filter cover**

When moving the filter cover in the direction of arrow to release the fitting, pay attention not to apply excessive force to the claws. Otherwise, the claws may be damaged.

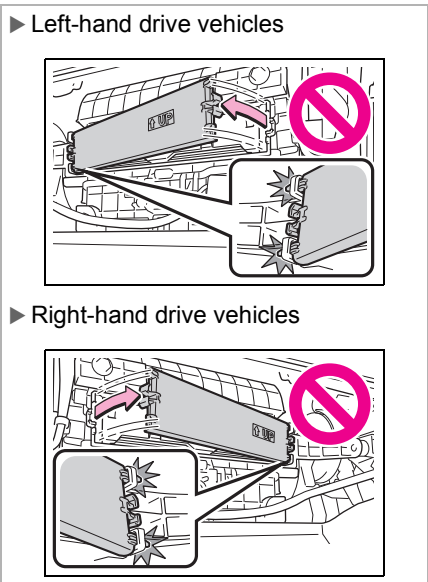

Cleaning the DC/DC Converter air intake vent and filter

To prevent the 12-volt battery from discharge, visually inspect the DC/DC Converter air intake vent periodically for dust and clogs. If it is dusty or clogged or if “Maintenance required for DCDC converter cooling parts See Owner’s Manual” is shown on the multi-information display, clean the air intake vent using the following procedures:

Cleaning the air intake vent

Remove the dust from the air intake vent with a vacuum cleaner, etc.

Make sure to only use a vacuum to suck out dust and clogs. Attempting to blow out dust and clogs using an airgun, etc. may push it into the air intake vent. (→P.480)

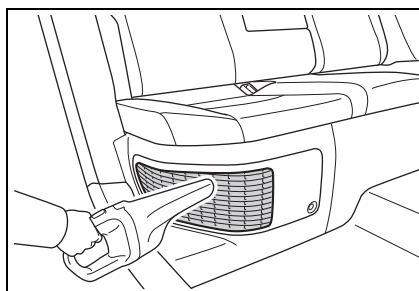

If dust and clogs cannot be completely removed

If dust and clogs cannot be com-

pletely removed with the air intake vent cover installed, remove the cover and clean the filter.

- 1 Turn the power switch off.
- 2 Using a Phillips screwdriver, remove the clip.

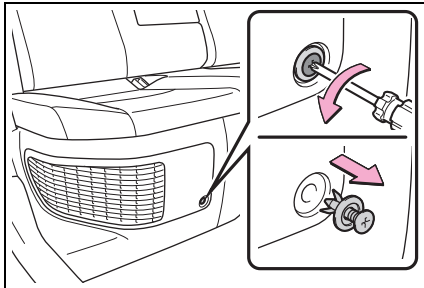

- 3 Remove the air intake vent cover.

Pull the cover as shown in the illustration to disengage the 8 claws, starting from the claw in the upper right corner and pull the cover toward the front of the vehicle to remove it.

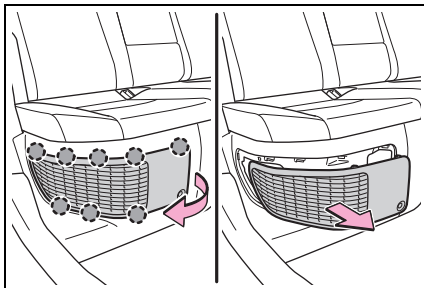

- 4 Remove the air intake vent filter. Disengage the 4 center claws from the filter.

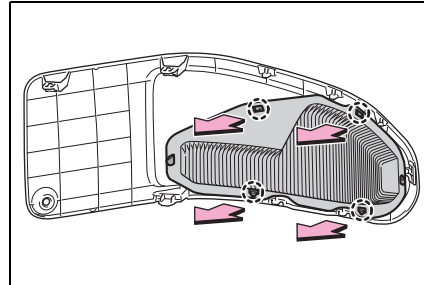

Disengage the claws in the order of **A** and **B** to remove the filter from the cover.

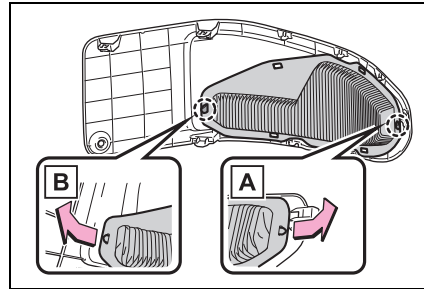

- 5 Remove the dust and clogs from the filter using a vacuum cleaner, etc.

Make sure to also remove the dust and clogs from the inside of the air intake vent cover.

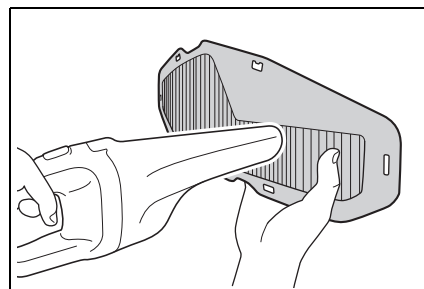

- 6 Reinstall the filter to the cover.

Engage the claws in the order of **B** and **A**.

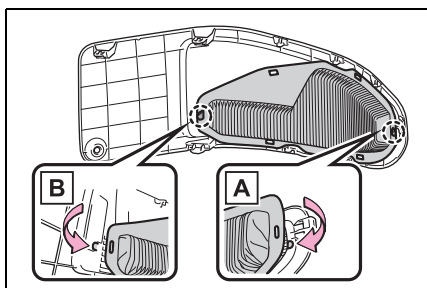

Engage the 4 center claws to install the filter.

Make sure that the filter is not crooked or deformed when installing it.

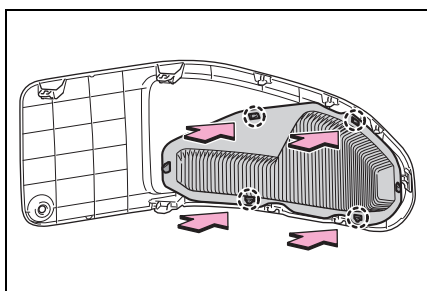

7 Install the air intake vent cover.

Insert the tab of the cover as shown in the illustration and push the cover to engage the 8 claws.

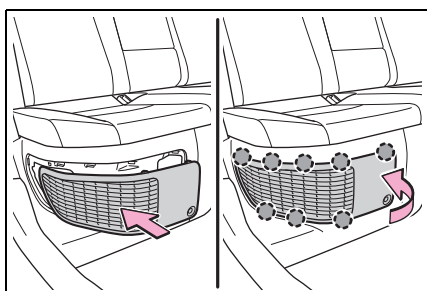

8 Using a Phillips screwdriver, install the clip.

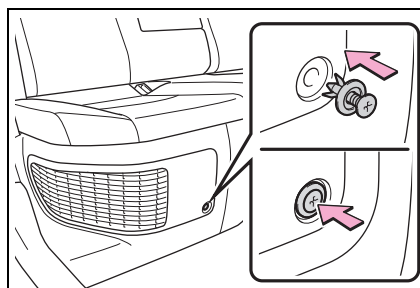

■ Cleaning the air intake vent

- Dust in the air intake vent may interfere with the cooling of the DC/DC converter. If the cooling performance/capacity of the DC/DC converter becomes limited, the 12-volt battery may discharge. Inspect and clean the air intake vent periodically.
- Improper handling of the air intake vent cover and filter may result in damage to them. If you have any concerns about cleaning the filter, contact a SUZUKI dealer or a qualified workshop.

■ If “Maintenance required for DCDC converter cooling parts See Owner’s Manual” is shown on the multi-information display

- If this warning message is shown on the multi-information display, remove the air intake vent cover and clean the filter. (→P.477)
- After cleaning the air intake vent, start the hybrid system and check that the warning message is no longer shown. It may take approximately 20 minutes after the hybrid system is started until the warning message disappears. If the warning message does not disappear, have the vehicle inspected by a SUZUKI dealer or a qualified workshop.

⚠ WARNING

■ **When cleaning the air intake vent**

- Do not use water or other liquids to clean the air intake vent. If water is applied to the DC/DC converter or other components, a malfunction or fire may occur.
- Before cleaning the air intake vent, make sure to turn the power switch off to stop the hybrid system.

⚠ NOTICE

■ **When cleaning the air intake vent**

When cleaning the air intake vent, make sure to only use a vacuum to suck out dust and clogs. If a compressed air blow gun, etc. is used to blow out dust and clogs, the dust or clogs may be pushed into the air intake vent, which may affect the performance of the DC/DC converter and cause a malfunction.

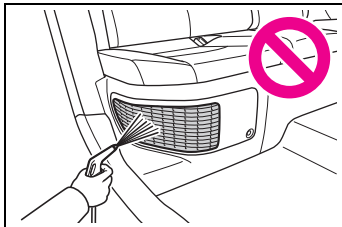

■ **To prevent damage to the vehicle**

- Do not allow water or foreign matter to enter the air intake vent when the cover is removed.
- Carefully handle the removed filter so that it will not be damaged. If the filter is damaged, have it replaced with a new filter by a SUZUKI dealer or a qualified workshop.
- Make sure to reinstall the filter and cover to their original positions after cleaning.

- Do not install anything to the air intake vent other than the exclusive filter for this vehicle or use the vehicle without the filter installed.

■ **If “Maintenance required for DCDC converter cooling parts See Owner’s Manual” is shown on the multi-information display**

If the vehicle is continuously driven with the warning message (indicating that the cooling performance/capacity of the DC/DC converter may become limited) displayed, the DC/DC converter may malfunction. If the warning message is displayed, clean the air intake vent immediately.

Wiper insert replacement

When replacing the wiper insert, perform the following procedure to operate each wiper.

Windshield wipers

Windshield wiper blade removal and installation

- 1 While holding the hook portion **A** of the wiper arm, first lift up the driver side, and then lift up the passenger side.

When returning the wiper arms to their original positions, first lower the passenger side, and then lower the driver side.

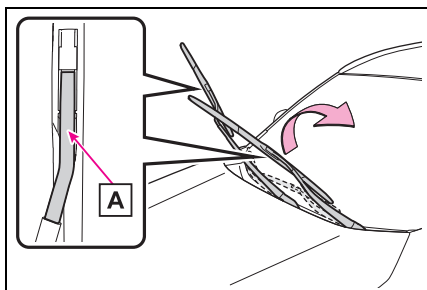

- 2 Lift the stopper using a flat-head screwdriver as shown in the illustration.

To prevent damage to the wiper arm, protect the tip of the screwdriver with a rag.

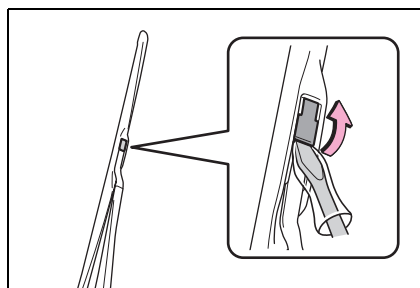

- 3 Slide the wiper blade to remove it from the wiper arm.

When installing, reverse the steps listed.

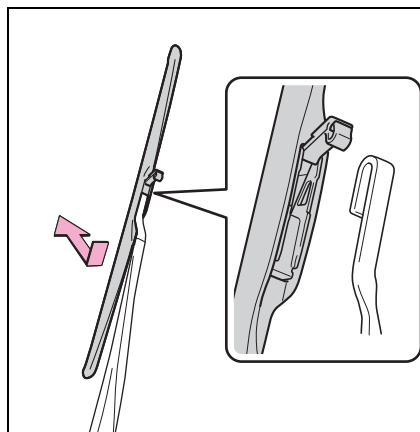

Wiper insert replacement

- 1 Pull the wiper insert to remove the claw of the wiper blade from the stopper, and pull out the wiper insert.

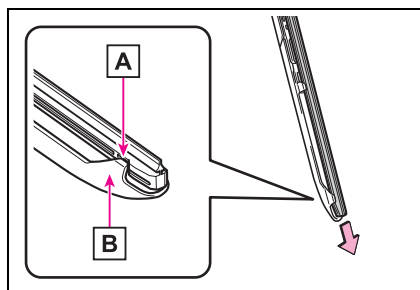

A Stopper

B Claw

- 2 Remove the 2 metal plates from the wiper insert pulled out, and install the plates to a new wiper insert.

Make sure that the cutout location and warp direction of the metal blades are same as the original.

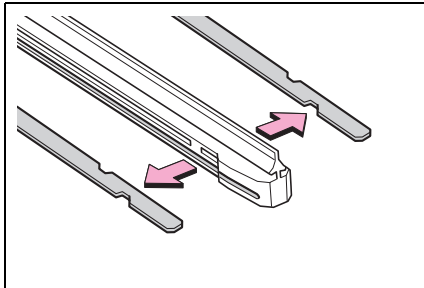

- 3 Install the wiper insert to the wiper blade from the side without the stopper.
- 4 Secure the stopper of the wiper insert with the claw of the wiper blade.

Rear window wiper

- 1 Move the wiper blade until a click sound can be heard and the claw detaches, and then

remove the wiper blade from the wiper arm.

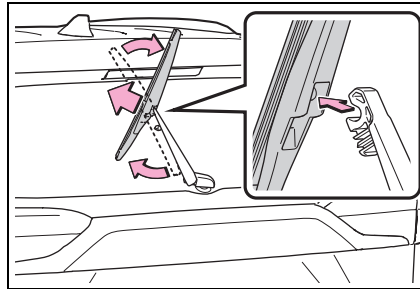

- 2 Pull the wiper insert out past the stopper on the wiper blade, and then continue to pull until it is completely removed.

Lightly grasp between the claws of the wiper blade to allow the wiper insert to lift up, making it easier to remove.

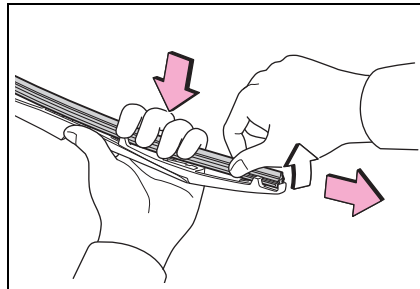

- 3 Remove the 2 metal plates from the old wiper insert and install them to the replacement wiper insert.

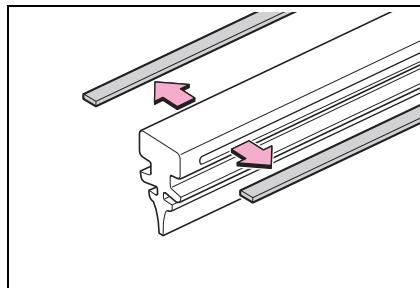

- 4** Insert the wiper insert starting from the claw at the center of the wiper blade. Pass the wiper insert through the 3 claws so that it sticks out from the stopper, and then pass the wiper insert through the final remaining claw.

Applying a small amount of washer fluid to the wiper insert can make it easier to insert the claws into the grooves.

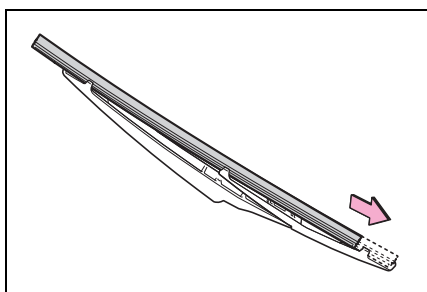

- 5** Check that the wiper blade claws are fitted in the grooves of the wiper insert.

If the wiper blade claws are not fitted in the grooves of the wiper insert, grasp the wiper insert and slide it back and forth multiple times to insert the claws into the grooves.

Lightly lift up the center of the wiper insert to make the rubber easier to slide.

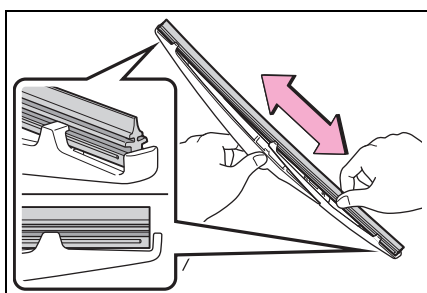

- 6** When installing a wiper blade, reverse the procedure in step **1**.

After installing the wiper blade, check that the connection is locked.

■ Wiper blade and wiper insert handling

Improper handling may result in damage to the wiper blades or wiper insert. If you have any concerns about replacing the wiper blades or wiper insert yourself, contact a SUZUKI dealer or a qualified workshop.

⚠ NOTICE

■ When lifting the windshield wipers

- When raising the wiper arms off the windshield, lift up the driver side first, and then lift up passenger side. When returning the wipers to their original position, return the passenger side first.
- Do not lift a windshield wiper by the wiper blade. Otherwise, the wiper blade may be deformed.
- Do not operate the wiper lever when the windshield wipers are lifted. Otherwise, the windshield wipers may contact the hood, possibly resulting in damage to the windshield wipers and/or hood.

■ To prevent damage

- Be careful not to damage the claws when replacing the wiper insert.
- After the wiper blade is removed from the wiper arm, place a cloth, etc., between the rear window and wiper arm to prevent damage to the rear window.
- Be sure not to pull excessively on the wiper insert or deform its metal plates.

Electronic key battery

Replace the battery with a new one if it is depleted.

■ If the key battery is depleted

The following symptoms may occur:

- The smart entry & start system and wireless remote control will not function properly.
- The operational range will be reduced.

Items to prepare

Prepare the following before replacing the battery:

- Flathead screwdriver
- Small flathead screwdriver
- Lithium battery CR2450

■ Use a CR2450 lithium battery

- Batteries can be purchased at a SUZUKI dealer or a qualified workshop, local electrical appliance shops or camera stores.
- Replace only with the same or equivalent type recommended by the manufacturer.
- Dispose of used batteries according to the local laws.

Replacing the battery

- 1 Release the lock and remove the mechanical key.

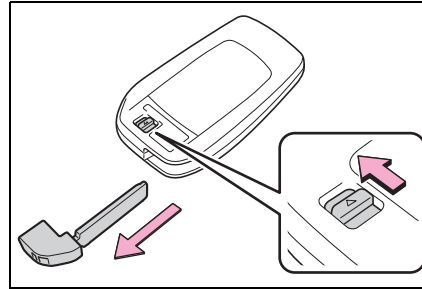

- 2 Remove the key cover.

Use a screwdriver of an appropriate size. Forcedly prying may cause the cover damaged.

To prevent damage to the key, cover the tip of the flathead screwdriver with a rag.

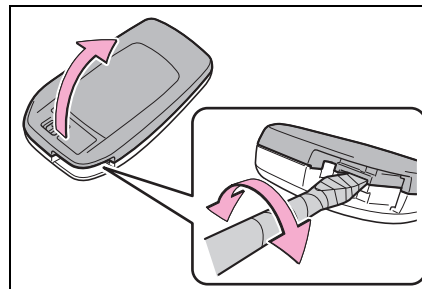

- 3 Remove the depleted battery using a small flathead screwdriver.

When removing the cover, the electronic key module may stick to the cover and the battery may not be visible. In this case, remove the electronic key module in order to remove the battery.

Insert a new battery with the “+” terminal facing up.

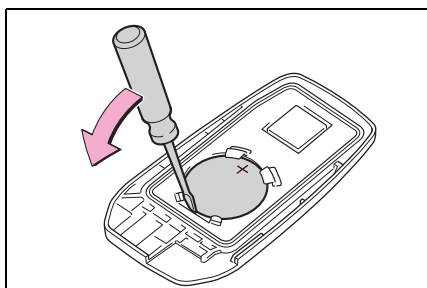

- 4 When installing, reverse the steps listed.

⚠ WARNING

■ **Battery precautions**

Observe the following precautions. Failure to do so may result in death or serious injury.

- Do not swallow the battery. Doing so may cause chemical burns.
- A coin battery or button battery is used in the electronic key. If a battery is swallowed, it may cause severe chemical burns in as little as 2 hours and may result in death or serious injury.
- Keep away new and removed batteries from children.
- If the cover cannot be firmly closed, stop using the electronic key and stow the key in the place where children cannot reach, and then contact a SUZUKI dealer or a qualified workshop.
- If you accidentally swallow a battery or put a battery into a part of your body, get emergency medical attention immediately.

■ **To prevent battery explosion or leakage of flammable liquid or gas**

- Replace the battery with a new battery of the same type. If a wrong type of battery is used, it may explode.

⚠ WARNING

- Do not expose batteries to extremely low pressure due to high altitude or extremely high temperatures.
- Do not burn, break or cut a battery.

■ **Certification for the electronic key battery**

CAUTION

RISK OF EXPLOSION IF BATTERY IS REPLACED BY AN INCORRECT TYPE.
DISPOSE OF USED BATTERIES ACCORDING TO THE INSTRUCTIONS

⚠ NOTICE

■ **When replacing the battery**

Use a flathead screwdriver of appropriate size. Applying excessive force may deform or damage the cover.

■ **For normal operation after replacing the battery**

Observe the following precautions to prevent accidents:

- Always work with dry hands. Moisture may cause the battery to rust.
- Do not touch or move any other component inside the remote control.
- Do not bend either of the battery terminals.

Checking and replacing fuses

If any of the electrical components do not operate, a fuse may have blown. If this happens, check and replace the fuses as necessary.

Checking and replacing fuses

- 1 Turn the power switch off.
Confirm that the charging connector is not connected. Also, do not use the Remote Air Conditioning System during the procedure.
- 2 Open the fuse box cover.
 - ▶ Engine compartment: Type A fuse box

Push claw **A** and **B** to completely release the lock, and then lift up the cover.

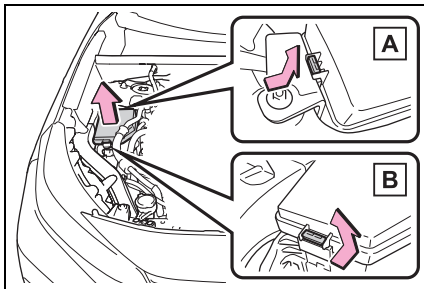

- ▶ Engine compartment: Type B fuse box

Push claw **A** and **B** to completely release the lock, and then lift up the cover.

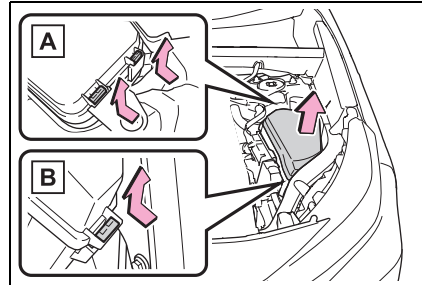

- ▶ Left side instrument panel

Left-hand drive vehicles: Remove the lid.

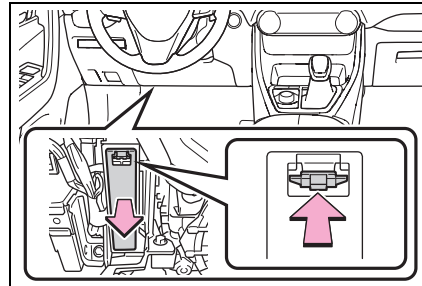

Right-hand drive vehicles: Push the tab in and remove the cover, and then remove the lid.

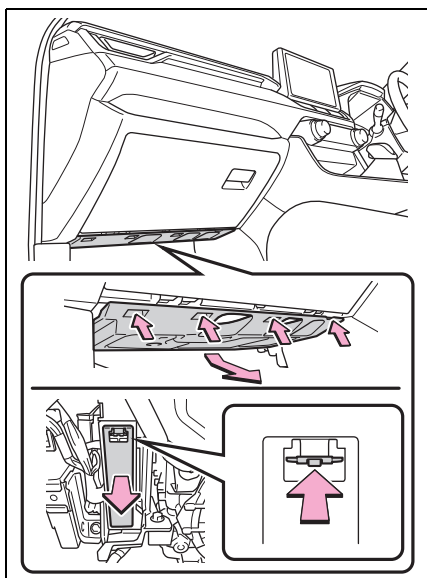

► Right side luggage compartment

Open the deck board. (→P.424)

Push claw **A** and **B** to completely release the lock, and then lift up the cover.

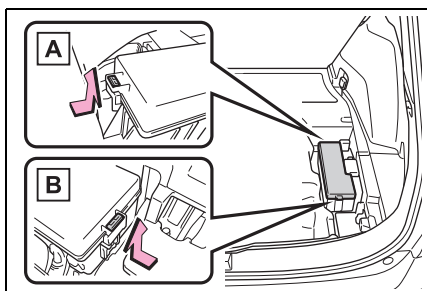

3 Remove the fuse.

Only type A fuse can be removed using the pullout tool.

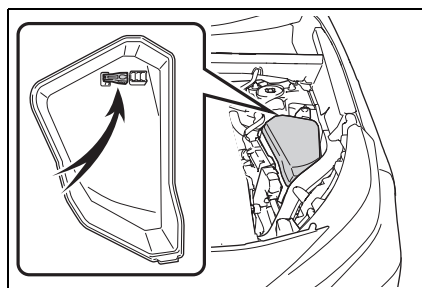

4 Check if the fuse is blown.

Replace the blown fuse with a new fuse of an appropriate amperage rating. The amperage rating can be found on the fuse box lid.

► Type A

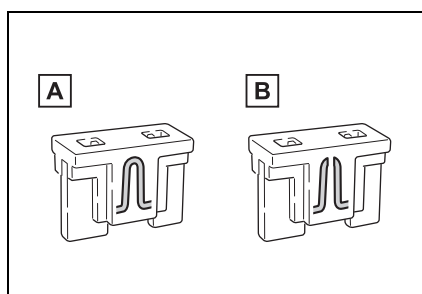

A Normal fuse

B Blown fuse

► Type B

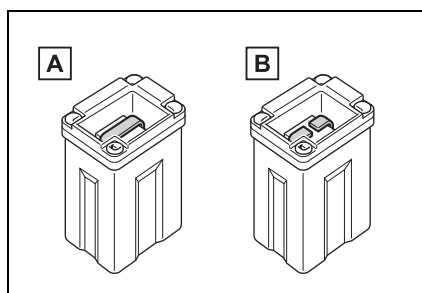

A Normal fuse

B Blown fuse

► Type C

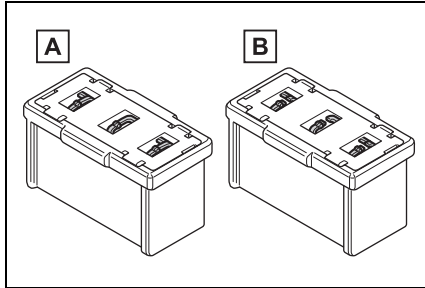

A Normal fuse

B Blown fuse

■ **After a fuse is replaced**

- When installing the lid, make sure that the tab is installed securely.
- If the lights do not turn on even after the fuse has been replaced, a bulb may need replacement. (→P.489)
- If the replaced fuse blows again, have the vehicle inspected by a SUZUKI dealer or a qualified workshop.

■ **If there is an overload in a circuit**

The fuses are designed to blow, protecting the wiring harness from damage.

■ **When replacing an electronic component, such as a lights, etc.**

Suzuki recommends that you use genuine Suzuki products designed for this vehicle. Because certain bulbs are connected to circuits designed to prevent overload, non-genuine parts or parts not designed for this vehicle may be unusable.

! WARNING

■ **To prevent system breakdowns and vehicle fire**

Observe the following precautions. Failure to do so may cause damage to the vehicle, and possibly a fire or injury.

- Never use a fuse of a higher amperage rating than that indicated, or use any other object in place of a fuse.
- Always use a genuine Suzuki fuse or equivalent. Never replace a fuse with a wire, even as a temporary fix.
- Do not modify the fuses or fuse boxes.

! NOTICE

■ **Before replacing fuses**

Have the cause of electrical overload determined and repaired by a SUZUKI dealer or a qualified workshop as soon as possible.

■ **To prevent damage to the engine compartment fuse box cover**

When opening the fuse box, completely release the claw locks before lifting up the cover. Otherwise, the claws may be damaged.

Light bulbs

You may replace the following bulbs by yourself. The difficulty level of replacement varies depending on the bulb. As there is a danger that components may be damaged, we recommend that replacement is carried out by a SUZUKI dealer or a qualified workshop.

Preparing for light bulb replacement

Check the wattage of the light bulb to be replaced. (→P.553)

Bulb location

► Front

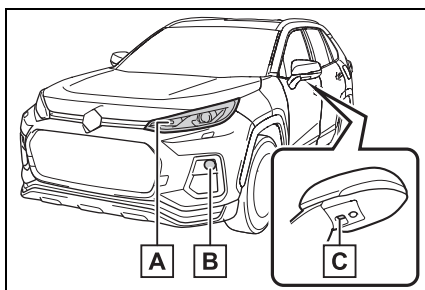

- A** Front turn signal lights
- B** Front fog lights
- C** Outer foot lights

► Rear

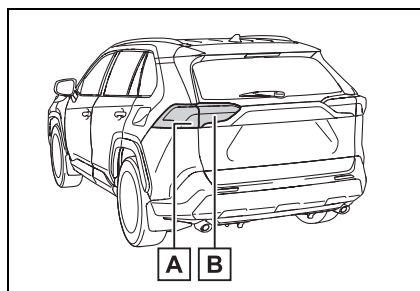

- A** Rear turn signal lights
- B** Back-up lights

■ Lights that need to be replaced by a SUZUKI dealer or a qualified workshop

- Headlights
- Daytime running lights
- Front position lights
- Side turn signal lights
- Tail lights
- Stop lights
- Rear fog light
- High mounted stoplight
- License plate lights

■ LED lights

The lights other than the following lights each consist of a number of LEDs. If any of the LEDs burn out, take your vehicle to a SUZUKI dealer or a qualified workshop to have the light replaced.

- Front turn signal lights
- Front fog lights
- Rear turn signal lights
- Back-up lights
- Outer foot lights

■ **Condensation build-up on the inside of the lens**

Temporary condensation build-up on the inside of the light lens does not indicate a malfunction. Contact a SUZUKI dealer or a qualified workshop for more information in the following situations:

- Large drops of water have built up on the inside of the lens.
- Water has built up inside the light.

■ **When replacing an electronic component, such as a lights, etc.**

→P.488

Replacing light bulb

■ **Front turn signal lights**

- 1 Remove the upper side part of the radiator support cover.

Using a flathead screwdriver, remove the securing clip, and pull the upper side part as shown in the illustration to disengage the claws (indicated by a dotted line).

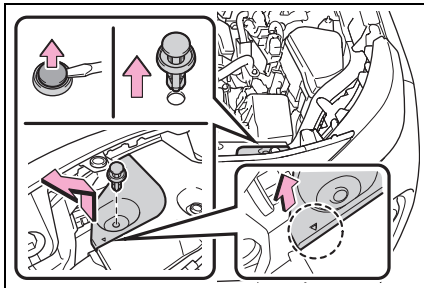

- 2 Turn the bulb base counter-clockwise.

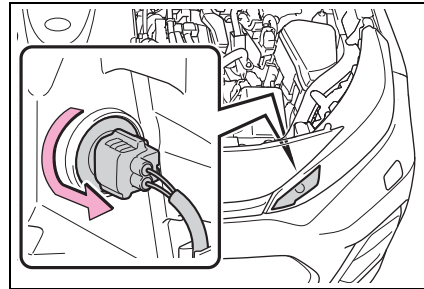

- 3 Remove the light bulb.

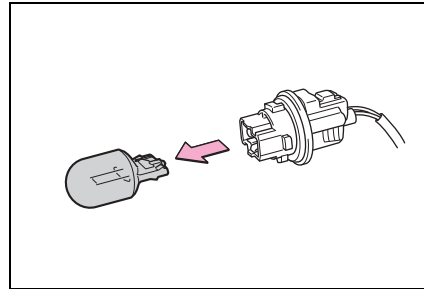

- 4 Install a new light bulb then install the bulb base to the light unit by inserting it and turning the bulb base clockwise.

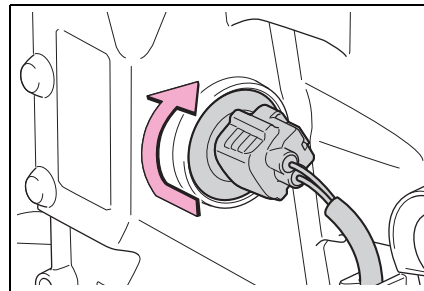

- 5 Reinstall the upper side part of the radiator support cover.

Insert the 2 tabs of the part as shown in the illustration and push the part to engage the claw, and secure the clip.

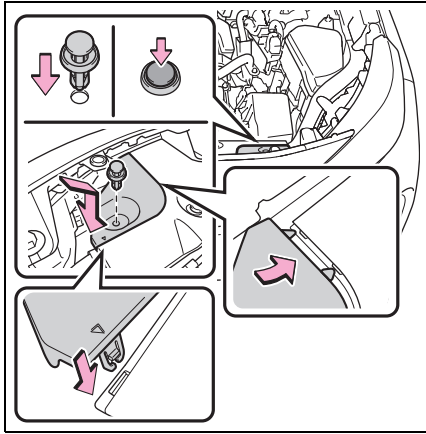

■ **Front fog lights**

1 To allow enough working space, turn the steering wheel.

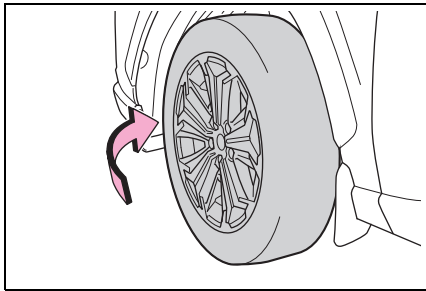

2 Remove the screws.

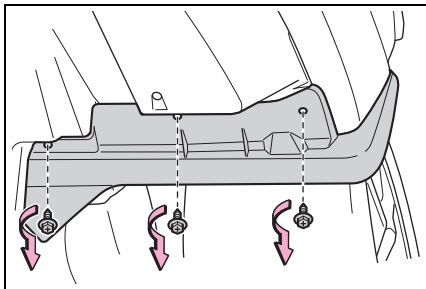

3 Remove the screws and clips, partly remove the fender liner.

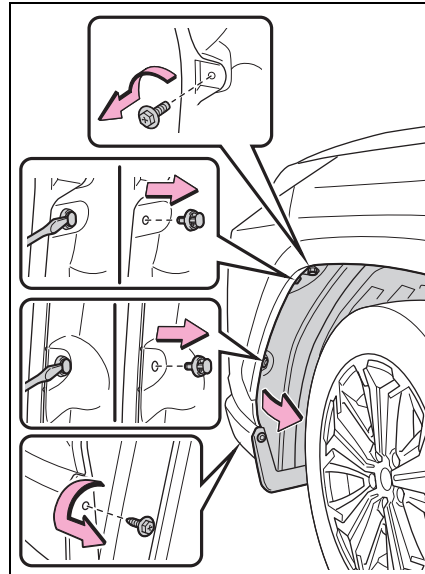

4 Unplug the connector.

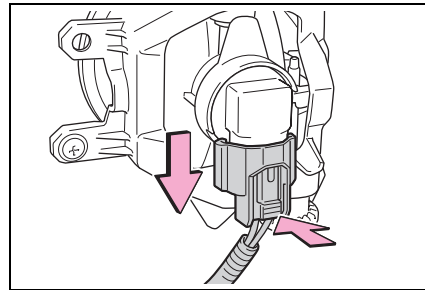

5 Turn the bulb base counter-clockwise.

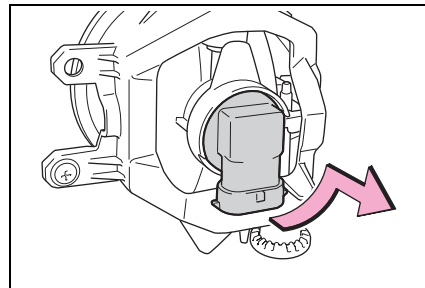

6 Set the new light bulb.

Align the 3 tabs on the light bulb with the mounting, and insert. Turn it clockwise to set.

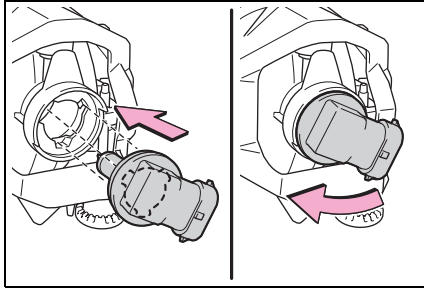

7 Set the connector.

Shake the bulb base gently to check that it is not loose, turn the front fog lights on once and visually confirm that no light is leaking through the mounting.

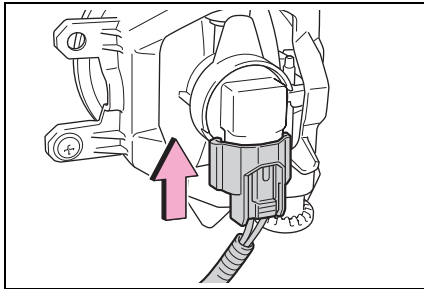

8 Reinstall the fender liner.

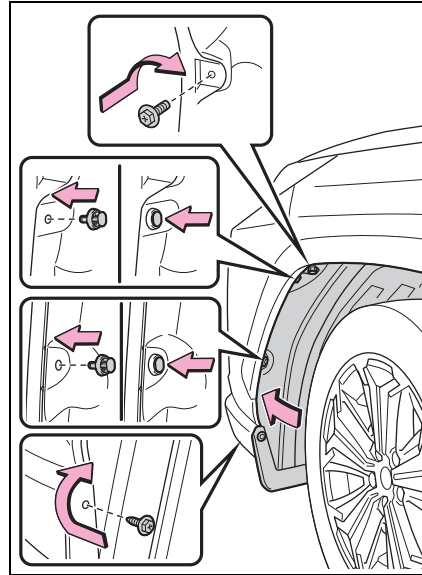

9 Reinstall the screws.

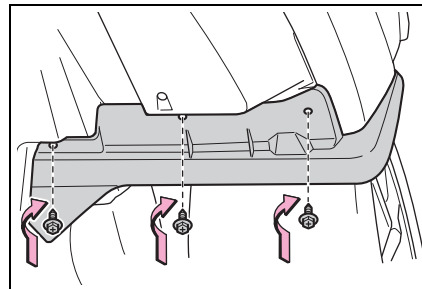

■ **Rear turn signal lights**

1 Open the back door and remove the cover.

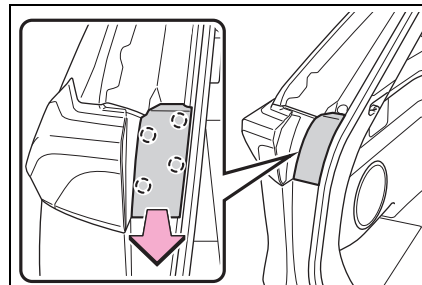

- 2** Remove the screws and remove the light unit.

Remove the light unit by pulling it directly backward from the rear of the vehicle.

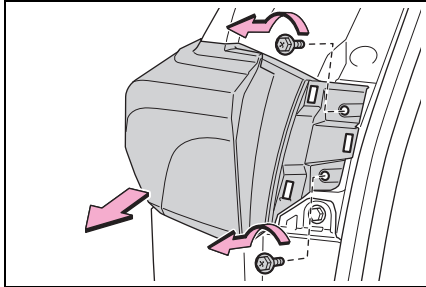

- 3** Turn the bulb base counter-clockwise.

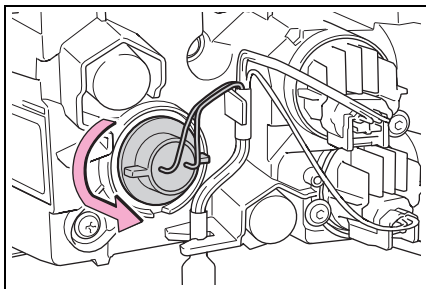

- 4** Remove the light bulb.

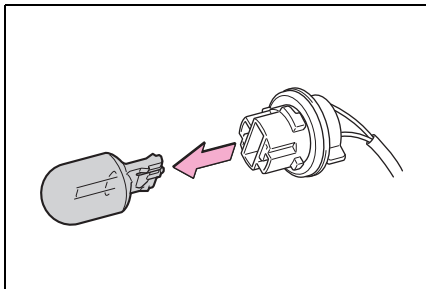

- 5** Install a new light bulb then install the bulb base to the light

unit by inserting it and turning the bulb base clockwise.

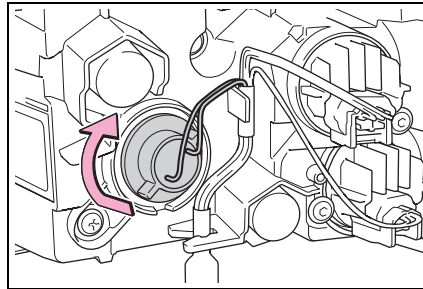

- 6** Align the grooves on the light unit with the claws, and insert the light unit straight so that the pin on the light unit fit into the hole.

Confirm that the light unit is completely secured.

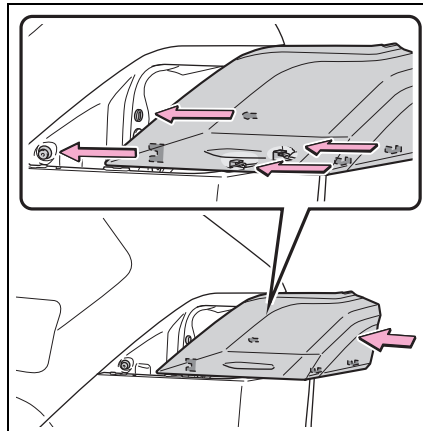

7 Reinstall the screws.

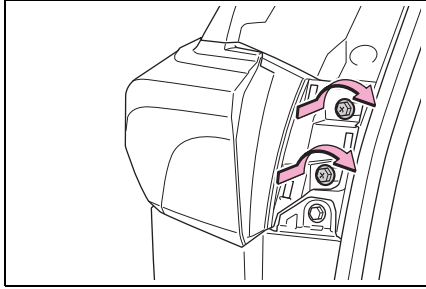

8 Reinstall the cover.

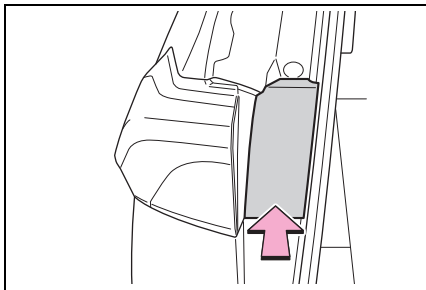

■ Back-up lights

1 Open the back door and remove the cover.

To prevent damage to the cover, protect the tip of the screwdriver with a rag.

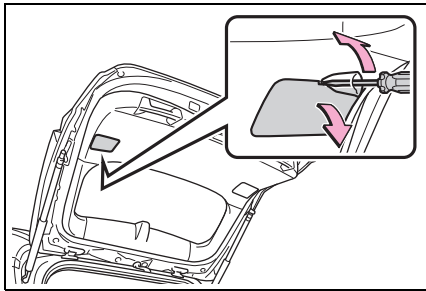

2 Turn the bulb base counter-clockwise.

Remove the cord from the clip before turning the bulb base.

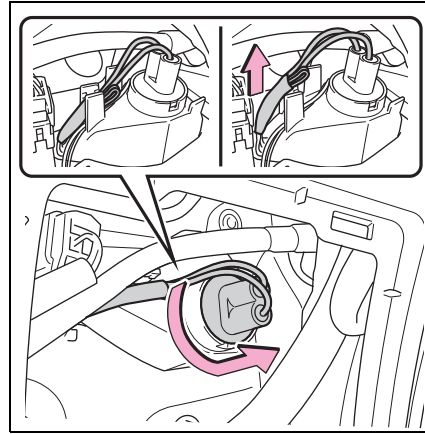

3 Remove the light bulb.

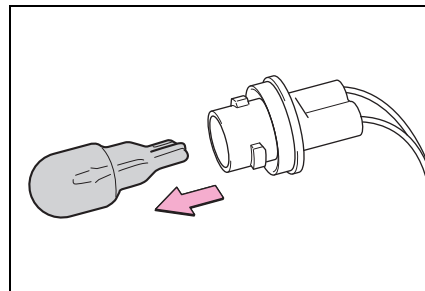

4 Install a new light bulb.

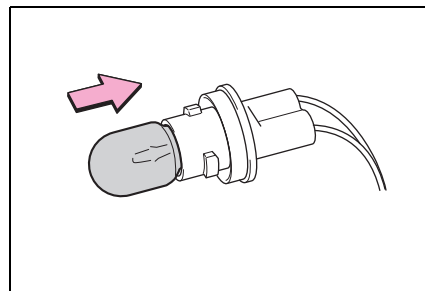

5 Install the bulb base to the light unit by inserting it and turning the bulb base clockwise.

Secure the cord with the clip back again after installing the bulb base.

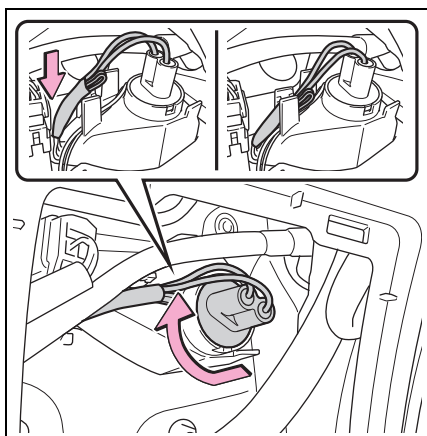

6 Reinstall the cover.

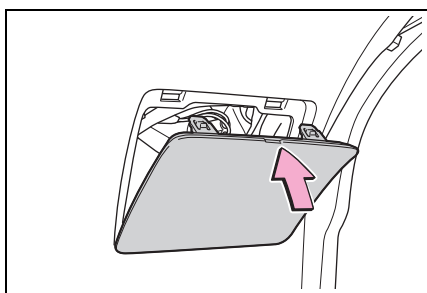

■ **Outer foot lights**

- 1** Press the upper part of the outside rear view mirror to tilt the mirror face upward, and disconnect the four tabs behind the mirror.

Pry the mirror out toward you, and disconnect two tabs at a time.

Work carefully, ensuring that you do not drop the mirror.

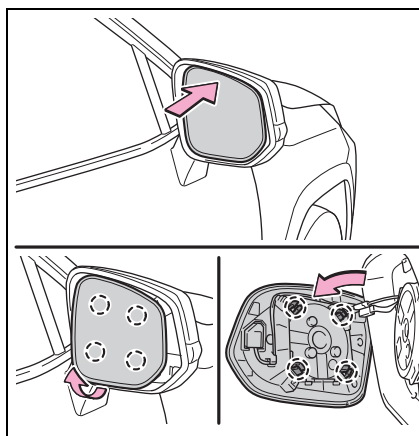

- 2** Disconnect the connectors behind the mirror, and remove the mirror.

Make sure to check the connectors, to avoid connecting upside down when reinstalling.

Work carefully, ensuring that you do not drop the mirror.

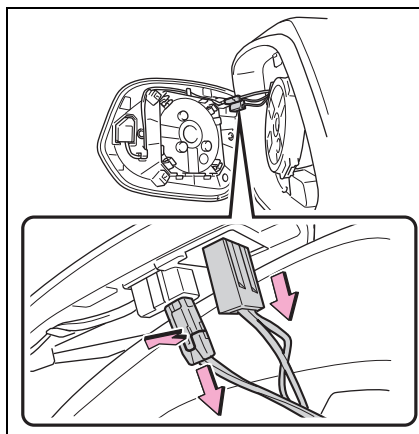

- 3** Disconnect the tabs behind the mirror cover, and remove the mirror cover.

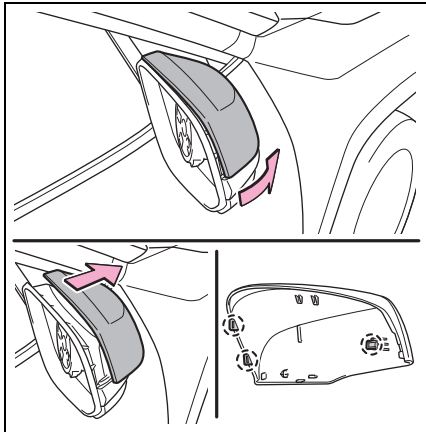

- 4** Fold the mirror before removing the light unit.

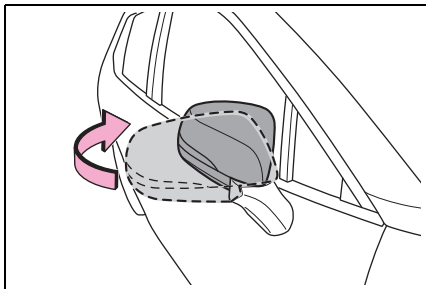

- 5** Remove the light unit.

Remove the two screws, and disengage the two tabs with a flat-head screwdriver.

Work carefully, ensuring that you do not damage the tabs.

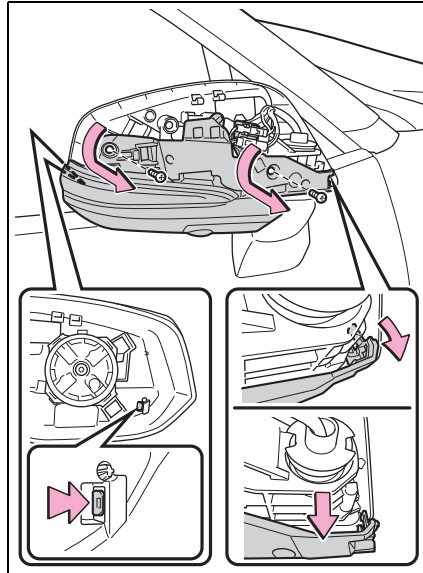

- 6** Turn the bulb base counter-clockwise.

Remove the cord from the clip before turning the bulb base.

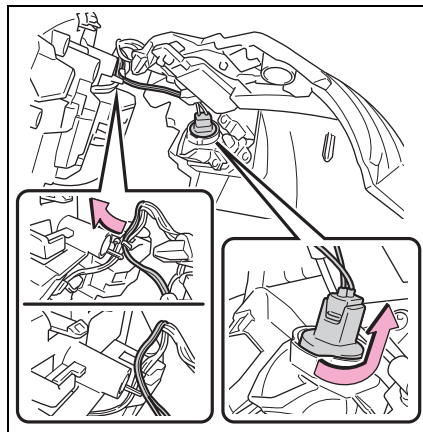

7 Remove the light bulb.

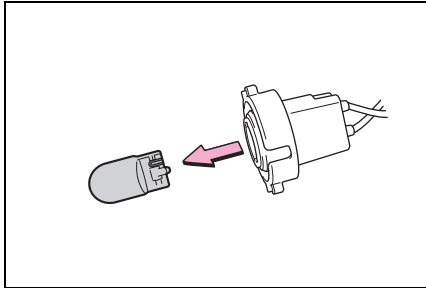

8 Install a new light bulb then install the bulb base to the light unit by inserting it and turning the bulb base clockwise.

Secure the cord with the clip back again after installing the bulb base.

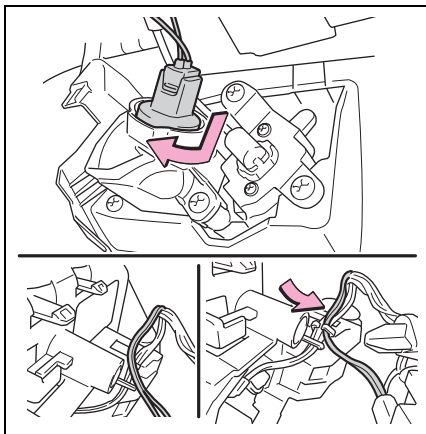

9 Install the light unit.

Make sure that the two tabs of the light unit are engaged securely, and install the two screws.

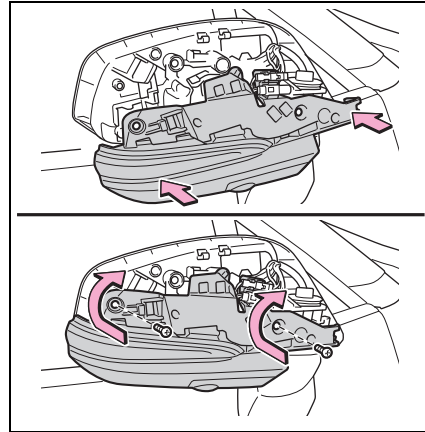

10 Extend the mirror.

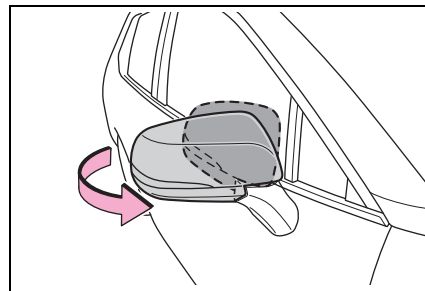

11 Install the mirror cover.

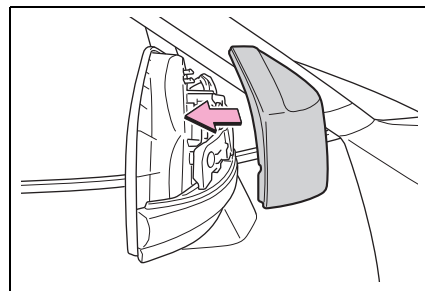

12 Reconnect the connectors of the mirror.

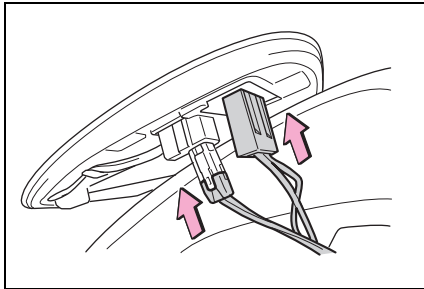

13 Align the tabs, and secure the mirror by pushing in each diagonally-opposite pair of tabs in order.

Make sure to insert the tabs in order as shown in the illustration, and push them in until a click is heard.

If you do not hear the click, do not force the tabs in. Instead, remove the mirror and check that the tabs are aligned.

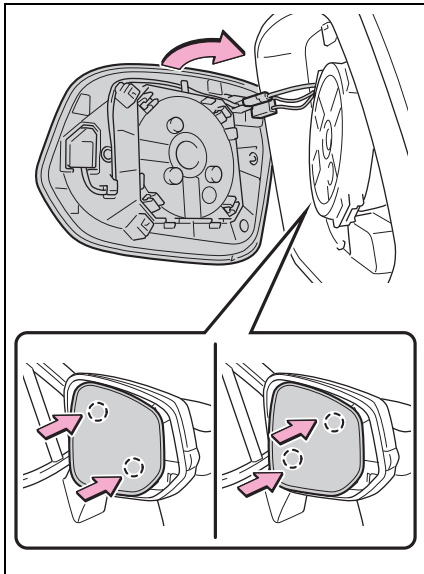

⚠ WARNING

■ Replacing light bulb

- Turn off the light. Do not attempt to replace the bulb immediately after turning off the light. The bulb become very hot and may cause burns.
 - Do not touch the glass portion of the light bulb with bare hands. When it is unavoidable to hold the glass portion, use and hold with a clean dry cloth to avoid getting moisture and oils on the bulb. Also, if the bulb is scratched or dropped, it may blow out or crack.
 - Fully install light bulb and any parts used to secure it. Failure to do so may result in heat damage, fire, or water entering the light unit. This may damage the light or cause condensation to build up on the lens.
 - Do not attempt to repair or disassemble light bulbs, connectors, electric circuits or component parts. Doing so may result in death or serious injury due to electric shock.
- To prevent damage or fire**
- Make sure bulb is fully seated and locked.
 - Check the wattage of the bulb before installing to prevent heat damage.

When trouble arises**8****8-1. Essential information**

Emergency flashers.....**500**

If your vehicle has to be
stopped in an emergency**500**

If the vehicle is trapped in rising
water.....**501**

8-2. Steps to take in an emergency

If your vehicle needs to be
towed.....**503**

If you think something is wrong
.....**506**

If a warning light turns on or a
warning buzzer sounds...**508**

If a warning message is displayed
.....**518**

If you have a flat tire**522**

If the hybrid system will not
start**530**

If you lose your keys.....**531**

If the fuel filler door cannot be
opened**532**

If the electronic key does not
operate properly**533**

If the 12-volt battery is discharged
.....**535**

If your vehicle overheats...**540**

If the vehicle becomes stuck
.....**543**

Emergency flashers

The emergency flashers are used to warn other drivers when the vehicle has to be stopped in the road due to a breakdown, etc.

Operating instructions

Press the switch.

All the turn signal lights will flash. To turn them off, press the switch once again.

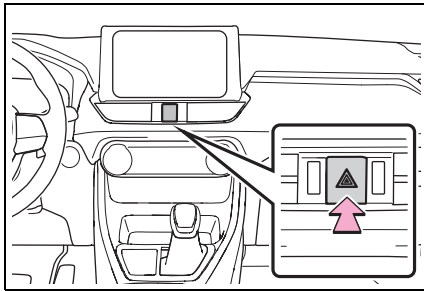

Emergency flashers

- If the emergency flashers are used for a long time while the hybrid system is not operating (while the “READY” indicator is not illuminated), the 12-volt battery may discharge.
- If any of the SRS airbags deploy (inflate) or in the event of a strong rear impact, the emergency flashers will turn on automatically. The emergency flashers will turn off automatically after operating for approximately 20 minutes. To manually turn the emergency flashers off, press the switch twice. (The emergency flashers may not turn on automatically depending on the force of the impact and conditions of the collision.)

If your vehicle has to be stopped in an emergency

Only in an emergency, such as if it becomes impossible to stop the vehicle in the normal way, stop the vehicle using the following procedure:

Stopping the vehicle

- 1 Steadily step on the brake pedal with both feet and firmly depress it.

Do not pump the brake pedal repeatedly as this will increase the effort required to slow the vehicle.

- 2 Shift the shift lever to N.
 - ▶ If the shift lever is shifted to N
- 3 After slowing down, stop the vehicle in a safe place by the road.
- 4 Stop the hybrid system.
 - ▶ If the shift lever cannot be shifted to N
- 3 Keep depressing the brake pedal with both feet to reduce vehicle speed as much as possible.

Press and hold the power switch for 2 consecutive seconds or more, or press it briefly 3 times or more in succession.

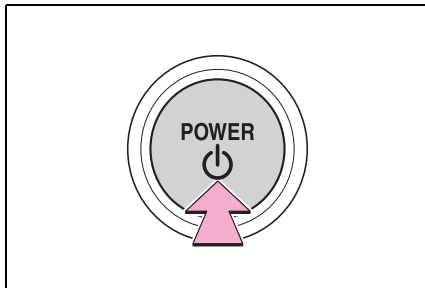

- 5** Stop the vehicle in a safe place by the road.

■ **If emergency stopped**

The functions of the air conditioning, etc. may be partially limited in order to reduce the power consumption of the 12-volt battery.

⚠ WARNING

■ **If the hybrid system has to be turned off while driving**

Turning the hybrid system off while driving will not cause a loss of steering or braking control. However, power assist for the steering wheel may be lost making it difficult to steer smoothly before stopping the vehicle depending on the remaining charge in the 12-volt battery or usage conditions. Decelerate as much as possible before turning off the hybrid system.

If the vehicle is trapped in rising water

In the event the vehicle is submerged in water, remain calm and perform the following.

- Remove the seat belt first.
- If the door can be opened, open the door and exit the vehicle.
- If the door can not be opened, open the window using the power window switch and exit the vehicle through the window.
- If the window can not be opened using the power window switch, remain calm, wait until the water level inside the vehicle rises to the point that the water pressure inside of the vehicle equals the water pressure outside of the vehicle, and then open the door and exit the vehicle.

⚠ WARNING

■ **Using an emergency hammer* for emergency escape**

The rear side windows and rear window of this vehicle can be shattered by an emergency hammer* used for emergency escape, however, since the windshield and front side windows are laminated glass they can not be shattered by an emergency hammer*.

*: Contact a SUZUKI dealer or a qualified workshop, or aftermarket accessory manufacturer for further information about an emergency hammer.



WARNING

■ **Escaping the vehicle from the window**

There are cases where escaping the vehicle from the window is not possible due to seating position, passenger body type, etc.

When using an emergency hammer, consider your seat location and the size of the window opening to ensure that the opening is accessible and large enough to escape.

If your vehicle needs to be towed

If towing is necessary, we recommend having your vehicle towed by a SUZUKI dealer or a qualified workshop or commercial towing service, using a wheel-lift type truck or flatbed truck.

Use a safety chain system for all towing, and abide by all state/provincial and local laws.

If towing your vehicle with a wheel-lift type truck, use a towing dolly. (→P.503, 504)

WARNING

Observe the following precautions. Failure to do so may result in death or serious injury.

■ When towing the vehicle

Be sure to transport the vehicle with all four wheels raised off the ground. If the vehicle is towed with the tires contacting the ground, the drivetrain or related parts may be damaged, the vehicle may fly off the truck, or electricity generated by the operation of the motor may cause a fire to occur depending on the nature of the damage or malfunction.

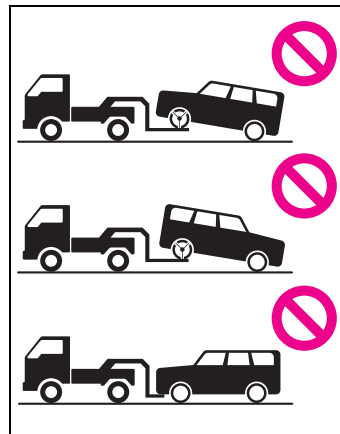

■ While towing

- When towing using cables or chains, avoid sudden starts, etc. which place excessive stress on the towing eyelets, cables or chains. The towing eyelets, cables or chains may become damaged, broken debris may hit people, and cause serious damage.
- Do not turn the power switch off. There is a possibility that the steering wheel is locked and cannot be operated.

■ Installing towing eyelets to the vehicle

Make sure that towing eyelets are installed securely. If not securely installed, towing eyelets may come loose during towing.



NOTICE

■ **To prevent damage to the vehicle when towing using a wheel-lift type truck**

● Do not tow the vehicle from the rear when the power switch is off. The steering lock mechanism is not strong enough to hold the front wheels straight.

● When raising the vehicle, ensure adequate ground clearance for towing at the opposite end of the raised vehicle. Without adequate clearance, the vehicle could be damaged while being towed.

■ **To prevent damage to the vehicle when towing with a sling-type truck**

Do not tow with a sling-type truck, either from the front or rear.

■ **To prevent damage to the vehicle during emergency towing**

Do not secure cables or chains to the suspension components.

Situations when it is necessary to contact dealers before towing

The following may indicate a problem with your transmission. Contact a SUZUKI dealer or a qualified workshop or commercial towing service before towing.

- The hybrid system warning message is shown on the multi-information display and the vehicle does not move.
- The vehicle makes an abnormal sound.

Towing with a wheel-lift type truck

- ▶ From the front

Use a towing dolly under the rear wheels.

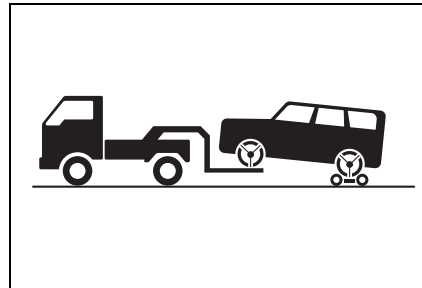

- ▶ From the rear

Use a towing dolly under the front wheels.

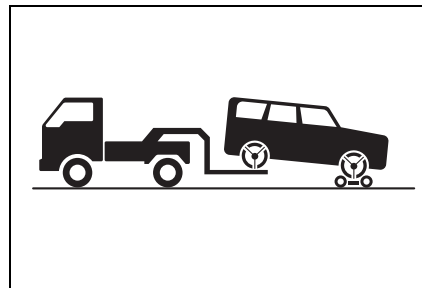

NOTICE

■ **Towing with a sling-type truck**

Do not tow with a sling-type truck to prevent body damage.

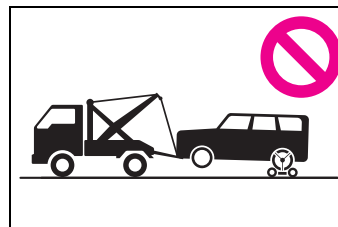

Using a flatbed truck

When using a flat-bed truck to transport the vehicle, use tire strapping belts. Refer to the owner's manual of the flat-bed truck for the tire strapping method.

In order to suppress vehicle movement during transportation, set the parking brake and turn the power switch off.

Emergency towing

If a tow truck is not available in an emergency, your vehicle may be temporarily towed using cables or chains secured to the emergency towing eyelets. This should only be attempted on hard surfaced roads for short distances at under 30 km/h (18 mph).

A driver must be in the vehicle to steer and operate the brakes. The vehicle's wheels, drive train, axles, steering and brakes must be in good condition.

Emergency towing procedure

To have your vehicle towed by another vehicle, the towing eyelet must be installed to your vehicle. Install the towing eyelet using the following procedure.

- 1 Take out the wheel nut wrench and towing eyelet. (→P.523)

- 2 Remove the eyelet cover using a flathead screwdriver.

To protect the bodywork, place a rag between the screwdriver and the vehicle body as shown in the illustration.

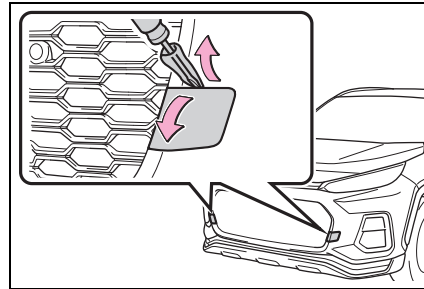

- 3 Insert the towing eyelet into the hole and tighten partially by hand.

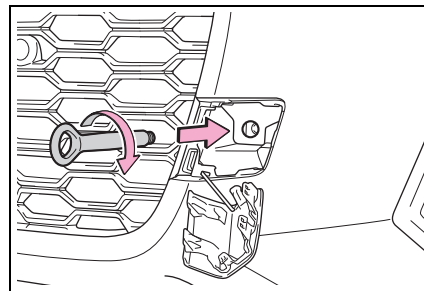

- 4 Tighten down the towing eyelet securely using a wheel nut wrench or hard metal bar.

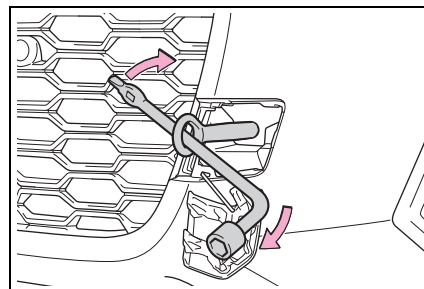

- 5 Securely attach cables or chains to the towing eyelet.

Take care not to damage the vehicle body.

- 6 Enter the vehicle being towed and start the hybrid system.

Turn off the Parking Support Brake function: →P.375

If the hybrid system does not start, turn the power switch to ON.

- 7 Shift the shift lever to N and release the parking brake.

Turn automatic mode off. (→P.289)

When the shift lever cannot be shifted: →P.285

■ While towing

If the hybrid system is not running, the power assist for the brakes and steering will not function, making steering and braking more difficult.

■ Wheel nut wrench

Wheel nut wrench is installed in the deck under tray. (→P.523)

If you think something is wrong

If you notice any of the following symptoms, your vehicle probably needs adjustment or repair. Contact a SUZUKI dealer or a qualified workshop as soon as possible.

Visible symptoms

- Fluid leaks under the vehicle (Water dripping from the air conditioning after use is normal.)
- Flat-looking tires or uneven tire wear
- High coolant temperature warning light flashes or come on

Audible symptoms

- Changes in exhaust sound
- Excessive tire squeal when cornering
- Strange noises related to the suspension system
- Pinging or other noises related to the hybrid system

Operational symptoms

- Engine missing, stumbling or running roughly
- Appreciable loss of power
- Vehicle pulls heavily to one side when braking

- Vehicle pulls heavily to one side when driving on a level road
- Loss of brake effectiveness, spongy feeling, pedal almost touches the floor

If a warning light turns on or a warning buzzer sounds

Calmly perform the following actions if any of the warning lights comes on or flashes. If a light comes on or flashes, but then goes off, this does not necessarily indicate a malfunction in the system. However, if this continues to occur, have the vehicle inspected by a SUZUKI dealer or a qualified workshop.

Actions to the warning lights or warning buzzers

■ Brake system warning light (warning buzzer)

Warning light	Details/Actions
 (Red)	Indicates that: <ul style="list-style-type: none"> ● The brake fluid level is low; or ● The brake system is malfunctioning → Immediately stop the vehicle in a safe place and contact a SUZUKI dealer or a qualified workshop. Continuing to drive the vehicle may be dangerous.

■ Brake system warning light

Warning light	Details/Actions
 (Yellow)	Indicates a malfunction in: <ul style="list-style-type: none"> ● The parking brake system; ● The regenerative braking system; or ● The electronically controlled brake system → Have the vehicle inspected by a SUZUKI dealer or a qualified workshop immediately.

■ Charging system warning light*

Warning light	Details/Actions
	Indicates a malfunction in the vehicle's charging system → Immediately stop the vehicle in a safe place and contact a SUZUKI dealer or a qualified workshop.

*: This light illuminates on the multi-information display.

■ High coolant temperature warning light* (warning buzzer)

Warning light	Details/Actions
	Indicates that the engine is overheating → Immediately stop the vehicle in a safe place. Handling method (→P.540)

*: This light illuminates on the multi-information display with a message.

■ Hybrid system overheat warning light* (warning buzzer)

Warning light	Details/Actions
	Indicates that the hybrid system has overheated → Stop the vehicle in a safe place. Handling method (→P.540)

*: This light illuminates on the multi-information display with a message.

■ Low engine oil pressure warning light* (warning buzzer)

Warning light	Details/Actions
	Indicates that the engine oil pressure is too low → Immediately stop the vehicle in a safe place and contact a SUZUKI dealer or a qualified workshop.

*: This light illuminates on the multi-information display with a message.

■ Malfunction indicator lamp*

Warning light	Details/Actions
	Indicates a malfunction in: ● The hybrid system; ● The electronic engine control system; ● The electronic throttle control system; or ● The emission control system (if equipped) → Have the vehicle inspected by a SUZUKI dealer or a qualified workshop immediately.

*: This light illuminates on the multi-information display.

■ **SRS warning light**

Warning light	Details/Actions
	Indicates a malfunction in: <ul style="list-style-type: none"> ● The SRS airbag system; or ● The seat belt pretensioner system → Have the vehicle inspected by a SUZUKI dealer or a qualified workshop immediately.

■ **ABS warning light**

Warning light	Details/Actions
	Indicates a malfunction in: <ul style="list-style-type: none"> ● The ABS; or ● The brake assist system → Have the vehicle inspected by a SUZUKI dealer or a qualified workshop immediately.

■ **Electric power steering system warning light* (warning buzzer)**

Warning light	Details/Actions
 <p>(Red/yellow)</p>	Indicates a malfunction in the EPS (Electric Power Steering) system → Have the vehicle inspected by a SUZUKI dealer or a qualified workshop immediately.

*: This light illuminates on the multi-information display.

■ PCS warning light (warning buzzer)

Warning light	Details/Actions
 <p>(Flashes or illuminates)</p>	<p>When a buzzer sounds simultaneously: Indicates a malfunction has occurred in the PCS (Pre-Collision System). → Have the vehicle inspected by a SUZUKI dealer or a qualified workshop immediately.</p> <p>When a buzzer does not sound: The PCS (Pre-Collision System) has become temporarily unavailable, corrective action may be necessary. → Follow the instructions displayed on the multi-information display. (→P.315, 521)</p> <p>If the PCS (Pre-Collision System) or VSC (Vehicle Stability Control) system is disabled, the PCS warning light will illuminate. → P.323</p>

■ LTA indicator* (warning buzzer)

Warning light	Details/Actions
 <p>(Orange)</p>	<p>Indicates a malfunction in the LTA (Lane Tracing Assist) → Follow the instructions displayed on the multi-information display. (→P.332)</p>

*: This light illuminates on the multi-information display.

■ Parking assist-sensor OFF indicator* (warning buzzer)

Warning light	Details/Actions
	<p>When a buzzer sounds: Indicates a malfunction in the parking assist-sensor function → Have the vehicle inspected by a SUZUKI dealer or a qualified workshop immediately.</p> <p>When a buzzer does not sound: Indicates that the system is temporarily unavailable, possibly due to a sensor being dirty or covered with ice, etc. → Follow the instructions displayed on the multi-information display. (→P.371, 518)</p>

*: This light illuminates on the multi-information display.

■ PKSB OFF indicator*

Warning light	Details/Actions
	<p>If "Parking Support Brake Malfunction Visit Your Dealer" is displayed on the multi-information display: Indicates a malfunction in the PKSB (Parking Support Brake) system → Have the vehicle inspected by a SUZUKI dealer or a qualified workshop immediately.</p> <p>If "Parking Assist Unavailable" is displayed on the multi-information display: Indicates that the system is temporarily unavailable, possibly due to a sensor being dirty or covered with ice, etc. → Follow the instructions displayed on the multi-information display. (→P.378, 518)</p>

*: This light illuminates on the multi-information display.

■ BSM OFF indicator* (warning buzzer)

Warning light	Details/Actions
	<p>Indicates a malfunction in the BSM (Blind Spot Monitor) function</p> <p>→ Have the vehicle inspected by a SUZUKI dealer or a qualified workshop immediately.</p> <p>Indicates that the rear bumper around the radar sensor is covered with dirt, etc. (→P.363)</p> <p>→ Follow the instructions displayed on the multi-information display. (→P.350, 518)</p>

*: This light illuminates on the multi-information display.

■ RCTA OFF indicator* (warning buzzer)

Warning light	Details/Actions
	<p>Indicates a malfunction in the RCTA (Rear Crossing Traffic Alert) function</p> <p>→ Have the vehicle inspected by a SUZUKI dealer or a qualified workshop immediately.</p> <p>Indicates that the rear bumper around the radar sensor is covered with dirt, etc. (→P.363)</p> <p>→ Follow the instructions displayed on the multi-information display. (→P.350, 518)</p>

*: This light illuminates on the multi-information display.

■ Slip indicator light

Warning light	Details/Actions
	<p>Indicates a malfunction in:</p> <ul style="list-style-type: none"> ● The VSC/Trailer Sway Control system; ● The TRC system; ● The Trail Mode function; or ● The hill-start assist control system <p>→ Have the vehicle inspected by a SUZUKI dealer or a qualified workshop immediately.</p>

■ Brake Override System/Drive-Start Control/PKSB warning light* (warning buzzer)

Warning light	Details/Actions
	<p>When a buzzer sounds:</p> <ul style="list-style-type: none"> ● Brake Override System is malfunctioning; ● Drive-Start Control is operating; ● Drive-Start Control is malfunctioning; or ● Parking Support Brake function (for static objects) is operating <p>→ Follow the instructions displayed on the multi-information display.</p> <p>When a buzzer does not sound: Brake Override System is operating</p> <p>→ Release the accelerator pedal and depress the brake pedal.</p>

*: This light illuminates on the multi-information display with a message.

■ Brake hold operated indicator (warning buzzer)

Warning light	Details/Actions
 <p>(Flashes)</p>	<p>Indicates a malfunction in the brake hold system</p> <p>→ Have the vehicle inspected by a SUZUKI dealer or a qualified workshop immediately.</p>

■ Parking brake indicator

Warning light	Details/Actions
 <p>(Flashes)</p>	<p>It is possible that the parking brake is not fully engaged or released</p> <p>→ Operate the parking brake switch once again.</p> <p>This light comes on when the parking brake is not released. If the light turns off after the parking brake is fully released, the system is operating normally.</p>

■ Tire pressure warning light*

Warning light	Details/Actions
	<p>When the light comes on after blinking for approximately 1 minute (a buzzer does not sound): Malfunction in the tire pressure warning system → Have the system checked by a SUZUKI dealer or a qualified workshop.</p> <p>When the light comes on (a buzzer sounds): Low tire inflation pressure from natural causes → Adjust the tire inflation pressure to the specified cold tire inflation pressure level. (→P.552)</p> <p>Low tire inflation pressure from flat tire → Immediately stop the vehicle in a safe place. Handling method (→P.516)</p>

*: This light illuminates on the multi-information display.

■ Low fuel level warning light

Warning light	Details/Actions
	<p>Indicates that remaining fuel is approximately 8.3 L (2.2 gal., 1.8 Imp. gal.) or less → Refuel the vehicle.</p>

■ Driver's and front passenger's seat belt reminder light (warning buzzer)*

Warning light	Details/Actions
	<p>Warns the driver and/or front passenger to fasten their seat belts → Fasten the seat belt. If the front passenger's seat is occupied, the front passenger's seat belt also needs to be fastened to make the warning light (warning buzzer) turn off.</p>

*: Driver's and front passenger's seat belt warning buzzer:

The driver's and front passenger's seat belt warning buzzer sounds to alert the driver and front passenger that his or her seat belt is not fastened. If the seat belt is unfastened, the buzzer sounds intermittently for a certain period of time after the vehicle reaches a certain speed.

■ Rear passengers' seat belt reminder lights*¹ (warning buzzer)*²

Warning light	Details/Actions
	Warns the rear passengers to fasten their seat belts → Fasten the seat belt.

*¹: This light illuminates on the multi-information display.

*²: Rear passengers' seat belt warning buzzer:

The rear passengers' seat belt warning buzzer sounds to alert the rear passenger that his or her seat belt is not fastened. If the seat belt is unfastened, the buzzer sounds intermittently for a certain period of time after the vehicle reaches a certain speed.

■ Warning buzzer

In some cases, the buzzer may not be heard because of noisy place or an audio sound.

■ Front passenger detection sensor, seat belt reminder and warning buzzer

- If luggage is placed on the front passenger seat, the front passenger detection sensor may cause the warning light to flash and the warning buzzer to sound even if a passenger is not sitting in the seat.
- If a cushion is placed on the seat, the sensor may not detect a passenger, and the warning light may not operate properly.

■ If the malfunction indicator lamp comes on while driving

The malfunction indicator lamp will come on if the fuel tank becomes completely empty. If the fuel tank is empty, refuel the vehicle immediately. The malfunction indicator lamp will go off after several trips.

If the malfunction indicator lamp does not go off, contact a SUZUKI dealer or a qualified workshop as soon as possible.

■ Electric power steering system warning light (warning buzzer)

When the 12-volt battery charge becomes insufficient or the voltage temporarily drops, the electric power steer-

ing system warning light may come on and the warning buzzer may sound.

At this time, the functions of the air conditioning, etc. may be partially limited in order to reduce the power consumption of the 12-volt battery.

■ When the tire pressure warning light comes on

Inspect the tires to check if a tire is punctured.

If a tire is punctured: →P.522

If none of the tires are punctured:

Turn the power switch to OFF then turn it to ON. Check if the tire pressure warning light comes on or blinks.

- ▶ If the tire pressure warning light blinks for approximately 1 minute then stays on

There may be a malfunction in the tire pressure warning system. Have the vehicle inspected by a SUZUKI dealer or a qualified workshop immediately.

- ▶ If the tire pressure warning light comes on

- 1 After the temperature of the tires has lowered sufficiently, check the inflation pressure of each tire and adjust them to the specified level.
- 2 If the warning light does not turn off even after several minutes have elapsed, check that the inflation pressure of each tire is at the specified level and perform initialization. (→P.465)

■ **The tire pressure warning light may come on due to natural causes**

The tire pressure warning light may come on due to natural causes such as natural air leaks and tire inflation pressure changes caused by temperature. In this case, adjusting the tire inflation pressure will turn off the warning light (after a few minutes).

■ **When a tire is replaced with a compact spare tire**

The compact spare tire is not equipped with a tire pressure warning valve and transmitter. If a tire goes flat, the tire pressure warning light will not turn off even though the flat tire has been replaced with the spare tire. Replace the spare tire with the standard tire and adjust the tire inflation pressure. The tire pressure warning light will go off after a few minutes.

■ **Conditions that the tire pressure warning system may not function properly**

→P.455



WARNING

■ **If a warning light comes on or a warning buzzer sounds when a warning message is shown on the multi-information display***

Check and follow the message shown on the multi-information display.

Failure to do so may result in death or serious injury.

*: Warning lights illuminate in red or yellow and the warning buzzer beeps once or sounds continuously.

■ **When the electric power steering system warning light comes on**

When the light comes on yellow, the assist to the power steering is restricted. When the light comes on red, the assist to the power steering is lost and handling operations of the steering wheel become extremely heavy.

If the steering wheel becomes heavier than usual when operating, hold firmly and operate using more force than usual.

■ **If the tire pressure warning light comes on**

Be sure to observe the following precautions. Failure to do so could cause a loss of vehicle control and result in death or serious injury.

- Stop your vehicle in a safe place as soon as possible. Adjust the tire inflation pressure immediately.
- If the tire pressure warning light comes on even after tire inflation pressure adjustment, it is probable that you have a flat tire. Check the tires. If a tire is flat, change it with the spare tire and have the flat tire repaired by the nearest SUZUKI dealer or a qualified workshop.
- Avoid abrupt maneuvering and braking. If the vehicle tires deteriorate, you could lose control of the steering wheel or the brakes.

■ **If a blowout or sudden air leakage should occur**

The tire pressure warning system may not activate immediately.



NOTICE

■ **To ensure the tire pressure warning system operates properly**

Do not install tires with different specifications or manufacturers, as the tire pressure warning system may not operate properly.

If a warning message is displayed

The multi-information display shows warnings of system malfunctions, incorrectly performed operations, and messages that indicate a need for maintenance. When a message is shown, perform the correction procedure appropriate to the message.

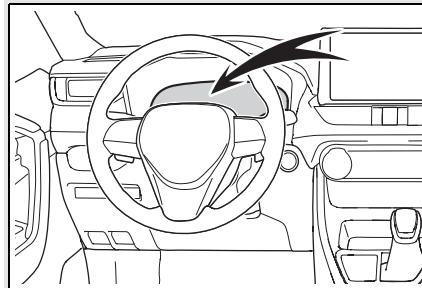

If a warning message is displayed again after the appropriate actions have been performed, contact a SUZUKI dealer or a qualified workshop.

When a message about charging is displayed, refer to P.152.

■ **Warning messages**

The warning messages explained below may differ from the actual messages according to operation conditions and vehicle specifications.

■ **If a message about an operation is shown**

- If a message about an operation of the accelerator pedal or brake pedal is shown

A warning message about an operation

of the brake pedal may be shown while the driving support systems such as PCS (Pre-Collision system) or the dynamic radar cruise control with full-speed range is operating. If a warning message is shown, be sure to decelerate the vehicle or follow an instruction shown on the multi-information display.

- A warning message is shown when Brake Override System operates. (→P.263, 514)
- A warning message is shown when Drive-Start Control or Parking Support Brake function (if equipped) operates (→P.263, 375). Follow the instructions on the multi-information display.
- If a message about an operation of the power switch is shown

An instruction for operation of the power switch is shown when the incorrect procedure for starting the hybrid system is performed or the power switch is operated incorrectly. Follow the instructions shown on the multi-information display to operate the power switch again.

- If a message about a shift lever operation is shown

To prevent the shift lever from being operated incorrectly or the vehicle from moving unexpectedly, a message that requires shifting the shift lever may be shown on the multi-information display. In that case, follow the instruction of the message and shift the shift lever.

- If a message or image about an open/close state of a part or replenishment of a consumable is shown

Confirm the part indicated by the multi-information display or a warning light, and then perform the coping method such as closing the open door or replenishing a consumable.

■ **If a message that indicates the need for visiting a SUZUKI dealer or a qualified workshop is displayed**

The system or part shown on the multi-information display is malfunctioning. Have the vehicle inspected by a SUZUKI dealer or a qualified workshop immediately.

■ **If a message that indicates the need for referring to Owner's Manual is displayed**

- If the following messages are shown, follow the instructions, accordingly.
 - "Blind Spot Monitor Unavailable" (→P.350, 518)
 - "RCTA Unavailable" (→P.350, 518)
 - "Engine Coolant Temp High" (→P.540)
 - "Exhaust Filter Full" (→P.391)
- If the following messages are shown, there may be a malfunction. Immediately stop the vehicle in a safe place and contact a SUZUKI dealer or a qualified workshop. Continuing to drive the vehicle may be dangerous.
 - "Plug-in charging system malfunction"
 - "Hybrid System Malfunction"
 - "Check Engine"
 - "Charging System Malfunction"
 - "Hybrid Battery System Malfunction"
 - "Accelerator System Malfunction"
 - "Smart Entry & Start System Malfunction"
- If the following messages are shown, there may be a malfunction. Immediately have the vehicle inspected by a SUZUKI dealer or a qualified workshop.
 - "Oil Pressure Low"
 - "Braking Power Low"
- If any of the following messages are shown on the multi-information display, the vehicle may have run out of fuel. Stop the vehicle in a safe place and, if the fuel level is low, refuel the vehicle.
 - "Hybrid System Stopped"
 - "Engine Stopped"
- If "Maintenance required for DCDC converter cooling parts See Owner's

Manual" is shown, the filter may be clogged, the air intake vent may be blocked, or there may be a gap in the duct. Therefore, perform the following correction procedure.

- If the air intake vent or filter of the DC/DC converter are dirty, perform the procedures on P.477 to clean them.
 - If the warning message is shown when the air intake vent and filter of the DC/DC converter are not dirty, have the vehicle inspected at a SUZUKI dealer or a qualified workshop.
- If "12-Volt Battery Charging System Malfunction Stop in a Safe Place See Owner's Manual" is shown

Indicates a malfunction in the vehicle's charging system. Pull over and stop the vehicle as soon as it is safe to do so.

While the message is displayed, the functions of the air conditioning, etc. may be partially limited in order to reduce the power consumption of the 12-volt battery.

■ If "Hybrid System Overheated Output Power Reduced" is shown

The message may be shown when driving under severe operating conditions. (For example, when driving up a long steep hill or driving up a steep hill in reverse.)

Coping method: →P.540

■ If "Traction Battery Needs to be Protected Refrain from the Use of N Position" is shown

This message may be displayed when the shift lever is in N.

As the hybrid battery (traction battery) cannot be charged when the shift lever is in N, shift the shift lever to P when the vehicle is stopped.

■ If "Traction Battery Needs to be Protected Shift into P to Restart" is shown

This message is displayed when the

hybrid battery (traction battery) charge has become extremely low because the shift lever has been left in N for a certain amount of time.

When operating the vehicle, shift to P and restart the hybrid system.

■ If "Shift to P when Parked" is shown

Message is displayed when the driver's door is opened without turning the power switch to OFF with the shift lever in any position other than P.

Shift the shift lever to P.

■ If "Shift is in N Release Accelerator Before Shifting" is shown

Message is displayed when the accelerator pedal has been depressed and the shift lever is in N. Release the accelerator pedal and shift the shift lever to D or R.

■ If "Press Brake when Vehicle is Stopped Hybrid System may Overheat" is shown

Message is displayed when the accelerator pedal is depressed to maintain the vehicle position when stopped on an upward slope, etc.

If this continues, the hybrid system may overheat.

Release the accelerator pedal and depress the brake pedal.

■ If "Auto Power OFF to Conserve Battery" is shown

Power was turned off due to the automatic power off function.

Next time when starting the hybrid system, operate the hybrid system for approximately 5 minutes to recharge the 12-volt battery.

■ If "Engine Oil Level Low Add or Replace" is displayed

The engine oil level may be low. Check the level of the engine oil, and add engine oil if necessary. This message may be displayed if the vehicle is stopped on a slope. Move the vehicle to a level surface and check if the mes-

sage disappears.

■ **If a message that indicates the malfunction of front camera is displayed**

The following systems may be suspended until the problem shown in the message is resolved. (→P.315, 508)

- PCS (Pre-Collision System)
- LTA (Lane Tracing Assist)
- Automatic High Beam
- RSA (Road Sign Assist)
- Dynamic radar cruise control with full-speed range

■ **If “Radar Cruise Control Unavailable See Owner’s Manual” is shown**

The dynamic radar cruise control with full-speed range system is suspended temporarily or until the problem shown in the message is resolved. (causes and coping methods: →P.315)

■ **If “Radar Cruise Control Unavailable” is shown**

The dynamic radar cruise control with full-speed range system cannot be used temporarily. Use the system when it becomes available again.

■ **Warning buzzer**

→P.516



WARNING

- **If a warning light comes on or a warning buzzer sounds when a warning message is shown on the multi-information display**

→P.517



NOTICE

■ **“High Power Consumption Partial Limit On AC/Heater Operation” is frequently shown**

There is a possible malfunction relating to the charging system or the 12-volt battery may be deteriorating. Have the vehicle inspected by a SUZUKI dealer or a qualified workshop.

■ **If “Maintenance required For Traction Battery At Your Dealer” is shown**

The hybrid battery (traction battery) is scheduled to be inspected or replaced. Have the vehicle inspected by a SUZUKI dealer or a qualified workshop immediately.

- Continuing to drive the vehicle without having the hybrid battery (traction battery) inspected will cause the hybrid system not to start.
- If the hybrid system does not start, contact a SUZUKI dealer or a qualified workshop immediately.

If you have a flat tire

Your vehicle is equipped with a spare tire. The flat tire can be replaced with the spare tire.
For details about tires: →P.452

WARNING

■ If you have a flat tire

Do not continue driving with a flat tire.

Driving even a short distance with a flat tire can damage the tire and the wheel beyond repair, which could result in an accident.

Before jacking up the vehicle

- Stop the vehicle in a safe place on a hard, flat surface.
- Set the parking brake.
- Shift the shift lever to P.
- Turn off the intrusion sensor and tilt sensor (→P.74)
- Stop the hybrid system.
- Turn on the emergency flashers. (→P.500)
- Turn off the power back door system. (→P.205)

Location of the spare tire, jack and tools

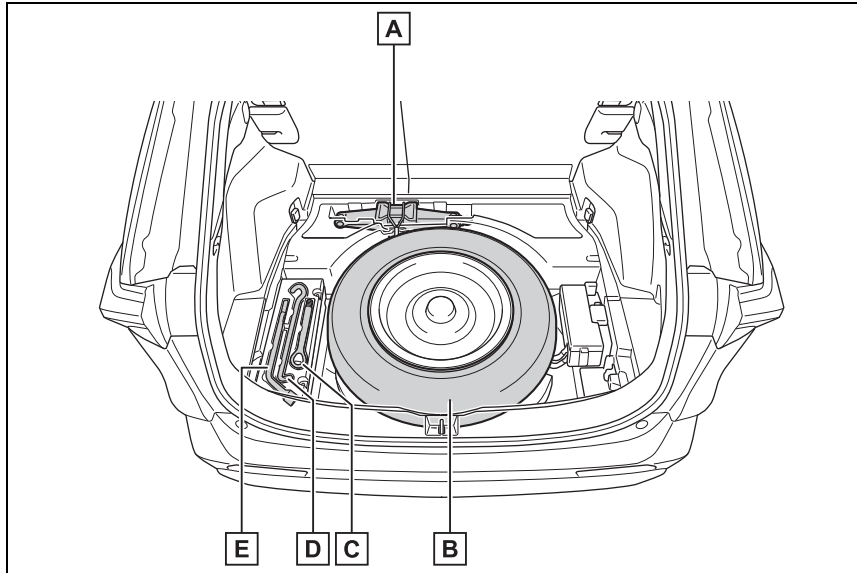

- A** Jack
- B** Spare tire
- C** Towing eyelet
- D** Jack handle
- E** Wheel nut wrench



WARNING

■ Using the tire jack

Observe the following precautions. Improper use of the tire jack may cause the vehicle to suddenly fall off the jack, leading to death or serious injury.

- Do not use the tire jack for any purpose other than replacing tires.
- The equipped jack can only be used with your vehicle. Do not use it with other vehicles.
- And do not use jacks from other vehicles with your vehicle.

- Put the jack properly in its jack point.

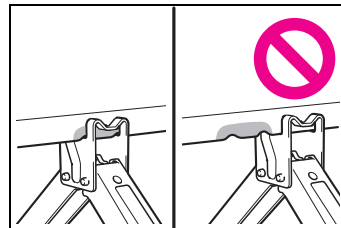

- Do not put any part of your body under the vehicle while it is supported by the jack.

⚠ WARNING

- Do not start the hybrid system or drive the vehicle while the vehicle is supported by the jack.
- Do not raise the vehicle while someone is inside.
- When raising the vehicle, do not put an object on or under the jack.
- Do not raise the vehicle to a height greater than that required to replace the tire.
- Use a jack stand if it is necessary to get under the vehicle.
- Stop the vehicle on firm, flat and level ground, firmly set the parking brake and shift the shift lever to P. Block the wheel diagonally opposite to the one being changed if necessary.
- When lowering the vehicle, make sure that there is no-one near the vehicle. If there are people nearby, warn them vocally before lowering.

Taking out the jack

- 1 Open the deck board. (→P.424).
- 2 Unhook the tightening strap and take out the jack from the deck under tray.

After taking out the jack, hold it in place by attaching the rubber band temporarily to the hole shown in the illustration.

To store the jack, rotate the jack and tighten until it no longer moves. Insert it into the deck under tray and then secure it in place with a rubber band.

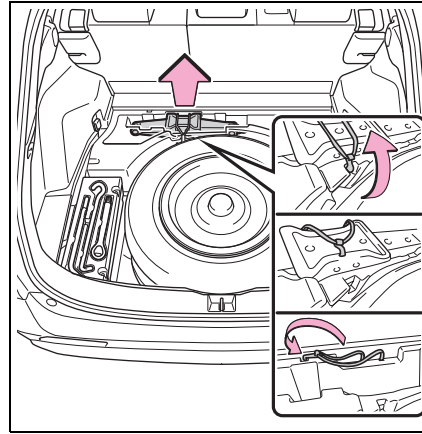

Taking out the tools

Take out the tools.

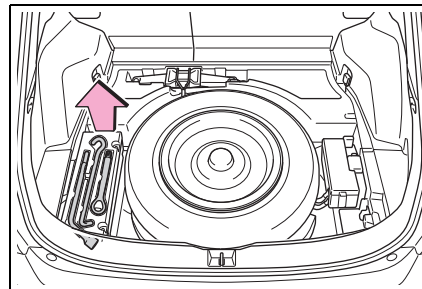

Taking out the spare tire

- 1 Take out the deck under tray.

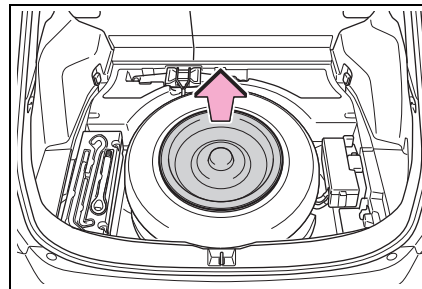

- 2 Loosen the center fastener that secures the spare tire, and then take out the spare tire.

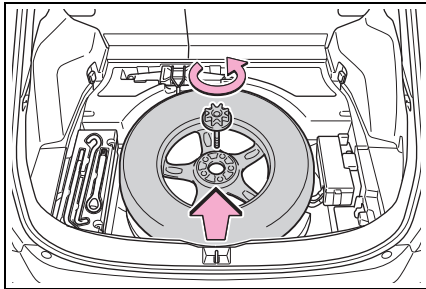

⚠ WARNING

■ **When storing the spare tire**
Be careful not to catch fingers or other body parts between the spare tire and the body of the vehicle.

Replacing a flat tire

- 1 Chock the tires.

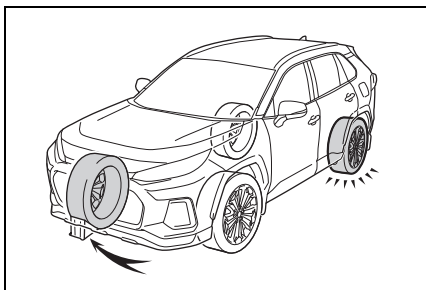

Flat tire	Wheel chock positions
Front left-hand side	Behind the rear right-hand side tire
Front right-hand side	Behind the rear left-hand side tire

Flat tire	Wheel chock positions
Rear left-hand side	In front of the front right-hand side tire
Rear right-hand side	In front of the front left-hand side tire

- 2 Slightly loosen the wheel nuts (one turn).

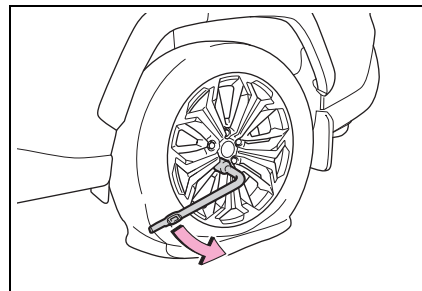

- 3 Turn the tire jack portion **A** by hand until the notch of the jack is in contact with the jack point.

The jack point guides are located under the rocker panel. They indicate the jack point positions.

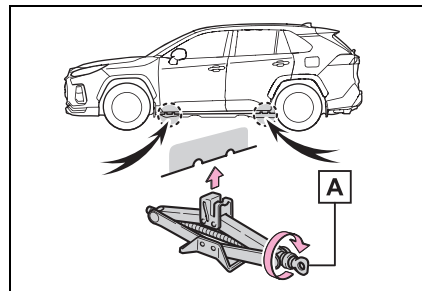

- 4 Assemble the jack handle and the wheel nut wrench as shown in the illustration.

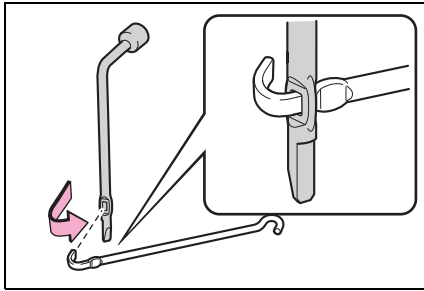

- 5 Raise the vehicle until the tire is slightly raised off the ground.

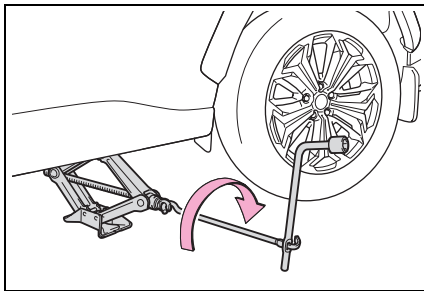

- 6 Remove all the wheel nuts and the tire.

When resting the tire on the ground, place the tire so that the wheel design faces up to avoid scratching the wheel surface.

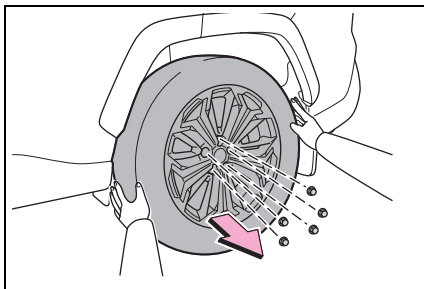

! WARNING

■ Replacing a flat tire

- Do not touch the disc wheels or the area around the brakes immediately after the vehicle has been driven.

After the vehicle has been driven the disc wheels and the area around the brakes will be extremely hot. Touching these areas with hands, feet or other body parts while changing a tire, etc. may result in burns.

- Failure to follow these precautions could cause the wheel nuts to loosen and the tire to fall off, resulting in death or serious injury.

- Have the wheel nuts tightened with a torque wrench to 103 N•m (10.5 kgf•m, 76 ft•lbf) as soon as possible after changing wheels.

- If there are any cracks or deformations in the bolt screws, nut threads or bolt holes of the wheel, have the vehicle inspected by a SUZUKI dealer or a qualified workshop.

- When installing the wheel nuts, be sure to install them with the tapered ends facing inward.

- In cases such as when replacing tires, make sure to turn off the power back door system (→P.205). Failure to do so may cause the back door to operate unintentionally if the power back door switch is accidentally touched, resulting in hands and fingers being caught and injured.

Installing the spare tire

- 1 Remove any dirt or foreign matter from the wheel contact surface.

If foreign matter is on the wheel contact

surface, the wheel nuts may loosen while the vehicle is in motion, causing the tire to come off.

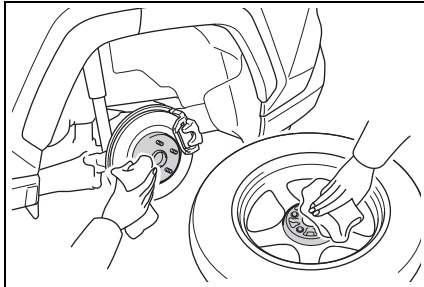

- 2** Install the spare tire and loosely tighten each wheel nut by hand by approximately the same amount.

Turn the wheel nuts until the washers

A come into contact with the disc wheel **B**.

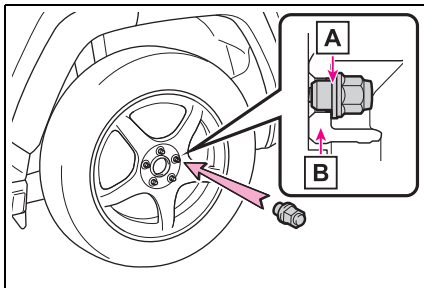

- 3** Lower the vehicle.

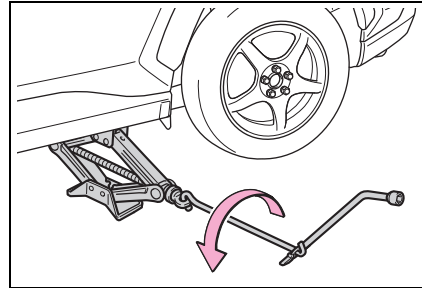

- 4** Firmly tighten each wheel nut two or three times in the order shown in the illustration.

Tightening torque:
103 N•m (10.5 kgf•m, 76 ft•lbf)

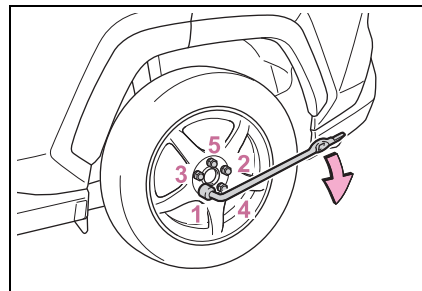

- 5** Stow the flat tire, tire jack and all tools.

■ The compact spare tire

- The compact spare tire is identified by the label "TEMPORARY USE ONLY" on the tire sidewall. Use the compact spare tire temporarily, and only in an emergency.
- Make sure to check the tire inflation pressure of the compact spare tire. (→P.553)

■ When using the compact spare tire

As the compact spare tire is not equipped with a tire pressure warning valve and transmitter, low inflation pres-

sure of the spare tire will not be indicated by the tire pressure warning system. Also, if you replace the compact spare tire after the tire pressure warning light comes on, the light remains on.

■ When the compact spare tire is attached

The vehicle height may become lower when driving with the compact spare tire compared to when driving with standard tires.

■ Certification for the jack



DECLARATION OF “CE” CONFORMANCE

EC Declaration of Conformity

1. The undersigned, Mr. Tony Fabiano, representing the manufacturer, herewith declares that the machinery described below fulfils all the relevant provisions of:

- Directive 2006/42/EC, on Machinery

2. Description of the machinery

- a) Part Name: Jack Assembly
- b) Part Number: 09111-0W150 (FNG P/N 0300336)
- c) Function: lifting motor vehicle
- d) Model: 810B
- e) OEM: Toyota

3. Manufacturer:

Flex-N-Gate / Seeburn Tottenham, 65 Industrial Road, Tottenham, ON, Canada L0G 1W0

4. Applicable Harmonizing Standards:

Not Applicable

5. Other Standards or Specifications:

Toyota Test Specification: TSF 9501G, Test Method for Car Jack Strength, Class C1, Rev. 6, April 2008

6. Done at:

Bradford, Ontario Canada

7. Date:

Dec-03-19

Tony Fabiano
Director of Engineering
Flex-N-Gate/Ventra
Bradford Product Development Centre

WARNING

■ **When using the compact spare tire**

- Remember that the compact spare tire provided is specifically designed for use with your vehicle. Do not use your compact spare tire on another vehicle.

- Do not use more than one compact spare tire simultaneously.

- Replace the compact spare tire with a standard tire as soon as possible.

- Avoid sudden acceleration, abrupt steering, sudden braking and shifting operations that cause sudden engine braking.

**WARNING****■ When the compact spare tire is attached**

The vehicle speed may not be correctly detected, and the following systems may not operate correctly:

- ABS & Brake assist
- VSC/Trailer Sway Control
- TRC
- Dynamic radar cruise control with full-speed range
- PCS (Pre-Collision System)
- EPS
- LTA (Lane Tracing Assist)
- Tire pressure warning system
- AHB (Automatic High Beam)
- BSM (Blind Spot Monitor)
- Rear view monitor system
- Parking assist monitor
- Parking assist-sensor
- PKSB (Parking Support Brake)

Also, not only can the following system not be utilized fully, but it may actually negatively affect the drive-train components:

- E-Four (Electronic On-Demand AWD system)

■ Speed limit when using the compact spare tire

Do not drive at speeds in excess of 80 km/h (50 mph) when a compact spare tire is installed on the vehicle.

The compact spare tire is not designed for driving at high speeds. Failure to observe this precaution may lead to an accident causing death or serious injury.

■ After using the tools and jack

Before driving, make sure all the tools and jack are securely in place in their storage location to reduce the possibility of personal injury during a collision or sudden braking.

**NOTICE****■ Be careful when driving over bumps with the compact spare tire installed on the vehicle**

The vehicle height may become lower when driving with the compact spare tire compared to when driving with standard tires. Be careful when driving over uneven road surfaces.

■ When replacing the tires

When removing or fitting the wheels, tires or the tire pressure warning valve and transmitter, contact a SUZUKI dealer or a qualified workshop as the tire pressure warning valve and transmitter may be damaged if not handled correctly.

If the hybrid system will not start

Reasons for the hybrid system not starting vary depending on the situation. Check the following and perform the appropriate procedure:

The hybrid system will not start even though the correct starting procedure is being followed (→P.279)

One of the following may be the cause of the problem:

- The AC charging cable may be attached to the vehicle. (→P.128)
- The electronic key may not be functioning properly. (→P.533)
- There may not be sufficient fuel in the vehicle's tank.
Refuel the vehicle. (→P.304)
- There may be a malfunction in the immobilizer system. (→P.71)
- There may be a malfunction in the steering lock system.
- The hybrid system may be malfunctioning due to an electrical problem such as electronic key battery depletion or a blown fuse. However, depending on the type of malfunction, an interim measure is available to start the hybrid system. (→P.530)
- There is a possibility that the temperature of the hybrid battery

(traction battery) is extremely low (approximately below -30°C [-22°F]). (→P.89, 280)

The interior lights and headlights are dim, or the horn does not sound or sounds at a low volume

One of the following may be the cause of the problem:

- The 12-volt battery may be discharged. (→P.535)
- The 12-volt battery terminal connections may be loose or corroded. (→P.451)

The interior lights and headlights do not turn on, or the horn does not sound

One of the following may be the cause of the problem:

- The 12-volt battery may be discharged. (→P.535)
- One or both of the 12-volt battery terminals may be disconnected. (→P.451)

Contact a SUZUKI dealer or a qualified workshop if the problem cannot be repaired, or if repair procedures are unknown.

Starting the hybrid system in an emergency

When the hybrid system does not start, the following steps can be

used as an interim measure to start the hybrid system if the power switch is functioning normally. Do not use this starting procedure except in cases of emergency.

- 1 Pull the parking brake switch to check that the parking brake is set. (→P.288)

Parking brake indicator will come on.

- 2 Shift the shift lever to P.
- 3 Turn the power switch to ACC.
- 4 Press and hold the power switch for about 15 seconds while depressing the brake pedal firmly.

Even if the hybrid system can be started using the above steps, the system may be malfunctioning. Have the vehicle inspected by a SUZUKI dealer or a qualified workshop.

If you lose your keys

New genuine keys can be made by a SUZUKI dealer or a qualified workshop using the other key and the key number stamped on your key number plate. Keep the plate in a safe place such as your wallet, not in the vehicle.



NOTICE

■ **When an electronic key is lost**

If the electronic key remains lost, the risk of vehicle theft increases significantly. Visit a SUZUKI dealer or a qualified workshop immediately with all remaining electronic keys that were provided with your vehicle.

If the fuel filler door cannot be opened

If the fuel filler door opener switch cannot be operated, contact a SUZUKI dealer or a qualified workshop to service the vehicle. In case where refueling is urgently necessary, the following procedure can be used to open the fuel filler door.

slowly.

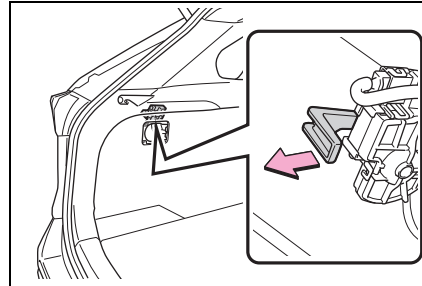

Opening the fuel filler door

- 1 Remove the cover inside the luggage compartment by inserting a screwdriver.

When removing the cover, to prevent damage, cover the tip of the screwdriver with a rag.

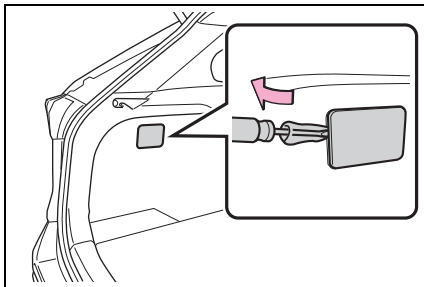

- 2 Pull the lever.

Using the lever to open the fuel filler door may not allow for an adequate reduction in fuel tank pressure before refueling. To prevent fuel from spilling out, turn the cap slowly when removing it.

During refueling, fuel may spill out from the filler opening due to air being discharged from inside the fuel tank. Therefore, fill the fuel tank carefully and

If the electronic key does not operate properly

If communication between the electronic key and vehicle is interrupted (→P.208) or the electronic key cannot be used because the battery is depleted, the smart entry & start system, push button start and wireless remote control cannot be used. In such cases, the doors can be opened and the hybrid system can be started by following the procedure below.

■ When the electronic key does not work properly

- Make sure that the smart entry & start system has not been deactivated in the customization setting. If it is off, turn the function on. (Customizable features: →P.558)
- Check if battery-saving mode is set. If it is set, cancel the function. (→P.208)

⚠ NOTICE

■ In case of a smart entry & start system malfunction, or other key related problems

Take your vehicle with all the electronic keys provided with your vehicle to a SUZUKI dealer or a qualified workshop.

Locking and unlocking the doors

Use the mechanical key (→P.190)

in order to perform the following operations.

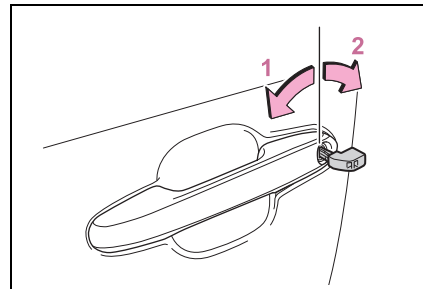

- 1 Locks all the doors
- 2 Unlocks all the doors

■ Key linked functions

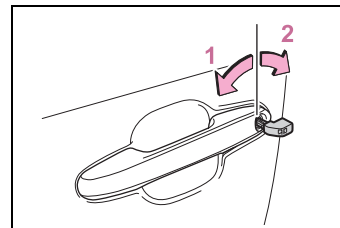

- 1 Closes the windows (turn and hold)*
- 2 Opens the windows (turn and hold)*

*: These settings must be customized at a SUZUKI dealer or a qualified workshop.

⚠ WARNING

■ When using the mechanical key and operating the power windows

Operate the power window after checking to make sure that there is no possibility of any passenger having any of their body parts caught in the window. Also, do not allow children to operate the mechanical key. It is possible for children and other passengers to get caught in the power window.

Starting the hybrid system

- 1 Ensure that the shift lever is in P and depress the brake pedal.
- 2 Touch the area behind the buttons on the electronic key to the power switch.

When the electronic key is detected, a buzzer sounds and the power switch will turn to ON.

When the smart entry & start system is deactivated in customization setting, the power switch will turn to ACC.

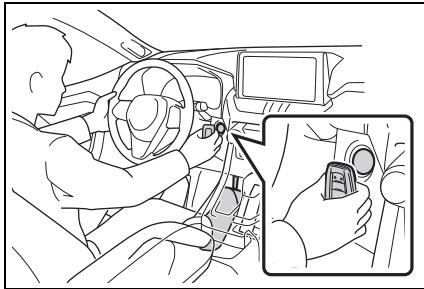

- 3 Firmly depress the brake pedal and check that  is displayed on the multi-information display.
- 4 Press the power switch shortly and firmly.

In the event that the hybrid system still cannot be started, contact a SUZUKI dealer or a qualified workshop.

Stopping the hybrid system

Shift the shift lever to P, set the parking brake and press the power switch as you normally do when stopping the hybrid system.

Replacing the key battery

As the above procedure is a temporary measure, it is recommended that the electronic key battery be replaced immediately when the battery is depleted. (→P.484)

Alarm

Using the mechanical key to lock the doors will not set the alarm system.

If a door is unlocked using the mechanical key when the alarm system is set, the alarm may be triggered. (→P.73)

Changing power switch modes

Release the brake pedal and press the power switch in step 3 above.

The hybrid system does not start and modes will be changed each time the switch is pressed. (→P.282)

If the 12-volt battery is discharged

The following procedures may be used to start the hybrid system if the vehicle's 12-volt battery is discharged. You can also call a SUZUKI dealer or a qualified workshop.

Restarting the hybrid system

If you have a set of jumper (or booster) cables and a second vehicle with a 12-volt battery, you can jump start your vehicle by following the steps below.

- 1 Confirm that the electronic key is being carried.

When connecting the jumper (or booster) cables, depending on the situation, the alarm may activate and the doors locked. (→P.74)

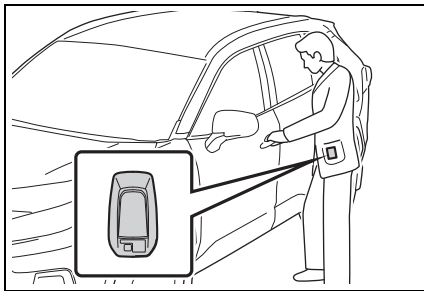

- 2 Open the hood (→P.442) and fuse box cover.

Push claw (A) and (B) to completely release the lock, and then lift up the cover.

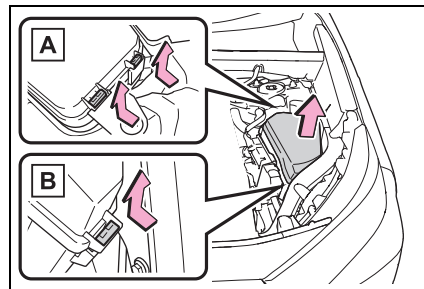

- 3 Open the exclusive jump starting terminal cover.

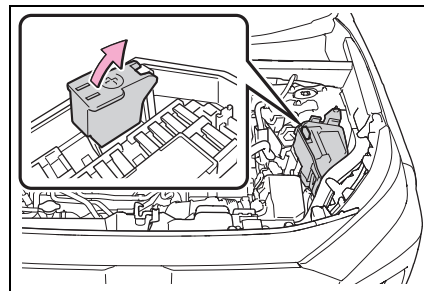

- 4 Connect a positive jumper cable clamp to (A) on your vehicle and connect the clamp on the other end of the positive cable to (B) on the second vehicle. Then, connect a negative cable clamp to (C) on the second

vehicle and connect the clamp at the other end of the negative cable to **D**.

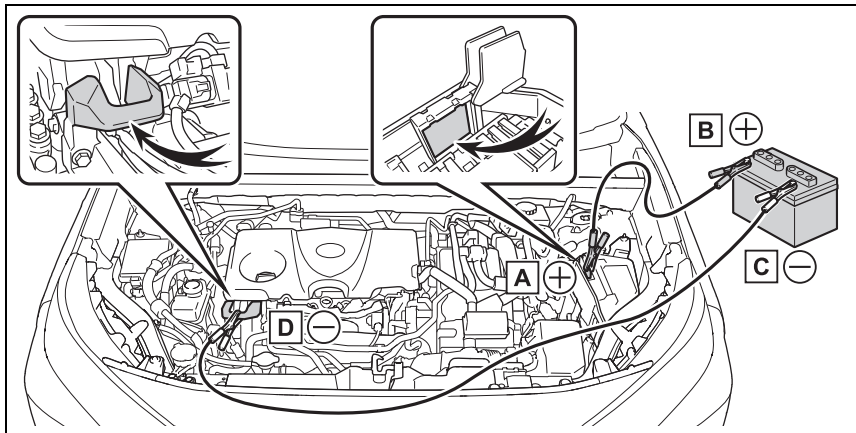

- A** Exclusive jump starting terminal (your vehicle)
- B** Positive (+) battery terminal (second vehicle)
- C** Negative (-) battery terminal (second vehicle)
- D** Solid, stationary, unpainted metallic point away from the exclusive jump starting terminal and any moving parts as shown in the illustration

- 5** Start the engine of the second vehicle. Increase the engine speed slightly and maintain at that level for approximately 5 minutes to recharge the 12-volt battery of your vehicle.
- 6** Open and close any of the doors of your vehicle with the power switch off.
- 7** Maintain the engine speed of the second vehicle and start the hybrid system of your vehicle by turning the power switch to ON.
- 8** Make sure the "READY" indicator comes on. If the indicator light does not come on, contact a SUZUKI dealer or a qualified workshop.
- 9** Once the hybrid system has started, remove the jumper cables in the exact reverse order from which they were connected.
- 10** Close the exclusive jump starting terminal cover, and reinstall the fuse box cover to its original position.

Once the hybrid system starts, have the vehicle inspected at a SUZUKI dealer or a qualified workshop as soon as possible.

■ Starting the hybrid system when the 12-volt battery is discharged

The hybrid system cannot be started by push-starting.

■ To prevent 12-volt battery discharge

- Turn off the headlights and the audio system while the hybrid system is off.
- Turn off any unnecessary electrical components when the vehicle is running at a low speed for an extended period, such as in heavy traffic.

■ When the 12-volt battery is removed or discharged

- Information stored in the ECU is cleared. When the 12-volt battery is depleted, have the vehicle inspected at a SUZUKI dealer or a qualified workshop.
- Some systems may require initialization. (→P.567)

■ When removing the 12-volt battery terminals

When the 12-volt battery terminals are removed, the information stored in the ECU is cleared. Before removing the 12-volt battery terminals, contact a SUZUKI dealer or a qualified workshop.

■ Charging the 12-volt battery

The electricity stored in the 12-volt battery will discharge gradually even when the vehicle is not in use, due to natural discharge and the draining effects of certain electrical appliances. If the vehicle is left for a long time, the 12-volt battery may discharge, and the hybrid system may be unable to start. (The 12-volt battery recharges automatically while the hybrid system is operating.)

■ When recharging or replacing the 12-volt battery

- In some cases, it may not be possible to unlock the doors using the smart entry & start system when the 12-volt battery is discharged. Use the wireless remote control or the mechanical

key to lock or unlock the doors.

- The hybrid system may not start on the first attempt after reinstalling the 12-volt battery. In that case, start the hybrid system in the same manner as when the electronic key does not operate properly (→P.534). This is not a malfunction, as the hybrid system will start normally on the second attempt.
- The power switch mode is memorized by the vehicle. When the 12-volt battery is reconnected, the system will return to the mode it was in before the 12-volt battery was discharged. Before disconnecting the 12-volt battery, turn the power switch off. If you are unsure what mode the power switch was in before the 12-volt battery discharged, be especially careful when reconnecting the 12-volt battery.

■ When replacing the 12-volt battery

- Use a 12-volt battery that conforms to European regulations.
- Use a 12-volt battery that the case size is same as the previous one (LN2), 20 hours rate capacity (20HR) is equivalent (55Ah) or greater, and performance rating (CCA) is equivalent (345A) or greater.
- If the sizes differ, the 12-volt battery cannot be properly secured.
- If the 20 hour rate capacity is low, even if the time period where the vehicle is not used is a short time, the 12-volt battery may discharge and hybrid system may not be able to start.
- Use a ventilation type calcium battery
- Use a 12-volt battery with a handle. If a 12-volt battery without a handle is used, removal is more difficult.
- When removing the 12-volt battery: →P.451
- After replacing, firmly attach the following items to the exhaust hole of the 12-volt battery.
- Use the exhaust hose that was attached to the 12-volt battery before

replacing and confirm that it is firmly connected to the hole section of the vehicle.

- Use the exhaust hole plug included with the new 12-volt battery or the one installed on the battery prior to the replacement.
(Depending on the new 12-volt battery installed, the exhaust hole may be plugged.)

For details, consult a SUZUKI dealer or a qualified workshop.

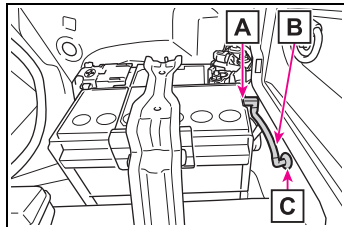

- A** Exhaust hole
- B** Exhaust hose
- C** Hole section of the vehicle

- The terminals can be connected to the body side when the negative terminal of the 12-volt battery is disconnected, as shown in the illustration.

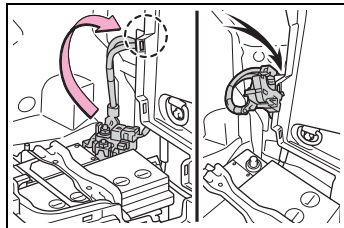

! WARNING

■ **When removing the battery terminals**

Always remove the negative (-) terminal first. If the positive (+) terminal contacts any metal in the surrounding area when the positive (+) terminal is removed, a spark may occur, leading to a fire in addition to electrical shocks and death or serious injury.

■ **Avoiding 12-volt battery fires or explosions**

Observe the following precautions to prevent accidentally igniting the flammable gas that may be emitted from the 12-volt battery:

- Make sure each jumper cable is connected to the correct terminal and that it is not unintentionally in contact with any other than the intended terminal.
- Do not allow the other end of the jumper cable connected to the “+” terminal to come into contact with any other parts or metal surfaces in the area, such as brackets or unpainted metal.
- Do not allow the + and - clamps of the jumper cables to come into contact with each other.
- Do not smoke, use matches, cigarette lighters or allow open flame near the 12-volt battery.

■ **12-volt battery precautions**

The 12-volt battery contains poisonous and corrosive acidic electrolyte, while related parts contain lead and lead compounds. Observe the following precautions when handling the 12-volt battery:

- When working with the 12-volt battery, always wear safety glasses and take care not to allow any battery fluids (acid) to come into contact with skin, clothing or the vehicle body.

⚠ WARNING

- Do not lean over the 12-volt battery.
- In the event that battery fluid comes into contact with the skin or eyes, immediately wash the affected area with water and seek medical attention.
Place a wet sponge or cloth over the affected area until medical attention can be received.
- Always wash your hands after handling the 12-volt battery support, terminals, and other battery-related parts.
- Do not allow children near the 12-volt battery.

■ After recharging the 12-volt battery

Have the 12-volt battery inspected at a SUZUKI dealer or a qualified workshop as soon as possible. If the 12-volt battery is deteriorating, continued use may cause the 12-volt battery to emit a malodorous gas, which may be detrimental to the health of passengers.

■ When replacing the 12-volt battery

- For information regarding 12-volt battery replacement, contact a SUZUKI dealer or a qualified workshop.

- After replacing, securely attach the exhaust hose and exhaust hole plug to the exhaust hole of the replaced 12-volt battery. If not properly installed, gases (hydrogen) may leak into the vehicle interior, and there is the possible danger of the gas igniting and exploding.

**⚠ NOTICE****■ When handling jumper cables**

When connecting the jumper cables, ensure that they do not become entangled in the cooling fan, etc.

■ To prevent damaging the vehicle

The exclusive jump starting terminal is to be used when charging the 12-volt battery from another vehicle in an emergency. It cannot be used to jump start another vehicle.

If your vehicle overheats

The following may indicate that your vehicle is overheating.

- The high coolant temperature warning light (→P.162) comes on or flashes, or a loss of hybrid system power is experienced. (For example, the vehicle speed does not increase.)
- “Engine Coolant Temp High Stop in a Safe Place See Owner’s Manual” or “Hybrid System Overheated Output Power Reduced” is shown on the multi-information display.
- Steam comes out from under the hood.

Correction procedures

■ If the high coolant temperature warning light comes on, flashes or “Engine Coolant Temp High Stop in a Safe Place See Owner’s Manual” is shown on the multi-information display

- 1 Stop the vehicle in a safe place and turn off the air conditioning system, and then stop the hybrid system.
- 2 If you see steam: Carefully lift the hood after the steam subsides.
If you do not see steam: Carefully lift the hood.

- 3 After the hybrid system has cooled down sufficiently, inspect the hoses and radiator core (radiator) for any leaks.

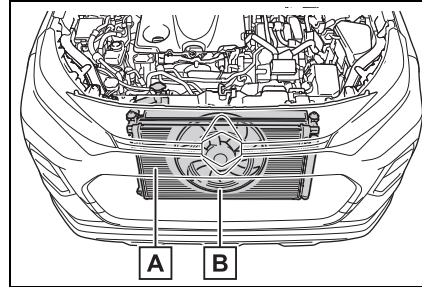

A Radiator

B Cooling fan

If a large amount of coolant leaks, immediately contact a SUZUKI dealer or a qualified workshop.

- 4 The coolant level is satisfactory if it is between the “FULL” and “LOW” lines on the reservoir.

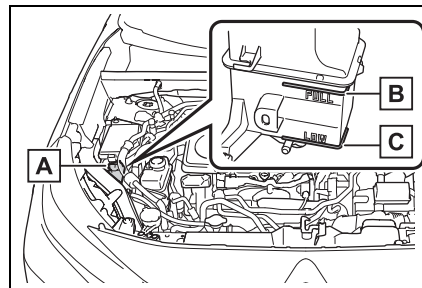

A Reservoir

B “FULL” line

C “LOW” line

- 5 Add coolant if necessary.

Water can be used in an emergency if engine coolant is unavailable. If water was added in an emergency, have the vehicle inspected at a

SUZUKI dealer or a qualified workshop as soon as possible.

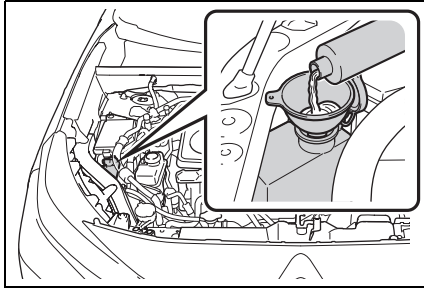

- 6** Start the hybrid system and turn the air conditioning system on to check that the radiator cooling fan operates and to check for coolant leaks from the radiator or hoses.

The fan operates when the air conditioning system is turned on immediately after a cold start. Confirm that the fan is operating by checking the fan sound and air flow. If it is difficult to check these, adjust the temperature control switch to “LO” and turn the “A/C” switch ON and OFF. After this, turn the air conditioning system on and off repeatedly. (The fan may not operate in freezing temperatures.)

- 7** If the fan is not operating:
Stop the hybrid system immediately and contact a SUZUKI dealer or a qualified workshop.
If the fan is operating:
Have the vehicle inspected at the nearest SUZUKI dealer or a qualified workshop.
- 8** Check if “Engine Coolant Temp High Stop in a Safe Place See Owner’s Manual” is shown on the multi-information display.
If the message does not disappear:

Stop the hybrid system and contact a SUZUKI dealer or a qualified workshop.

If the message is not displayed:
Have the vehicle inspected at the nearest SUZUKI dealer or a qualified workshop.

■ **If “Hybrid System Overheated Output Power Reduced” is shown on the multi-information display**

- 1** Stop the vehicle in a safe place.
- 2** Stop the hybrid system and carefully lift the hood.
- 3** After the hybrid system has cooled down, inspect the hoses and radiator core (radiator) for any leaks.

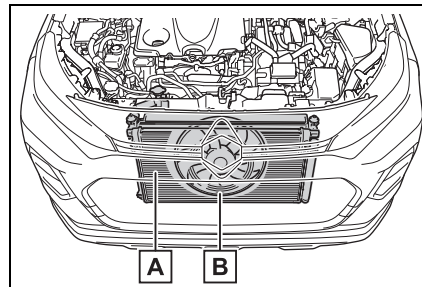

A Radiator

B Cooling fan

If a large amount of coolant leaks, immediately contact a SUZUKI dealer or a qualified workshop.

- 4 The coolant level is satisfactory if it is between the “FULL” and “LOW” lines on the reservoir.

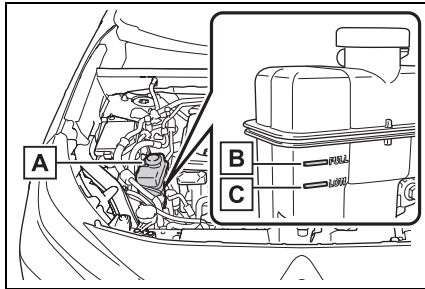

- A Reservoir
- B “FULL” line
- C “LOW” line

- 5 Add coolant if necessary.

Water can be used in an emergency if power control unit coolant is unavailable.

If water was added in an emergency, have the vehicle inspected at a SUZUKI dealer or a qualified workshop as soon as possible.

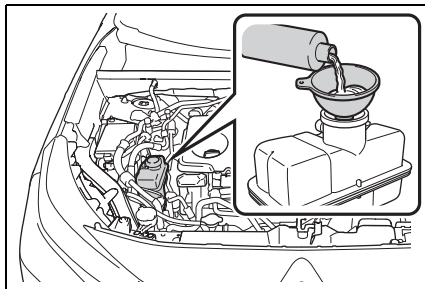

- 6 After stopping the hybrid system and waiting for 5 minutes or more, start the hybrid system again and check the multi-information display.
- If the message does not disappear: Stop the hybrid system

and contact a SUZUKI dealer or a qualified workshop.

If the message is not displayed: The hybrid system temperature has dropped and the vehicle may be driven normally.

However, if the message appears again frequently, contact a SUZUKI dealer or a qualified workshop.

WARNING

When inspecting under the hood of your vehicle

Observe the following precautions. Failure to do so may result in serious injury such as burns.

- If steam is seen coming from under the hood, do not open the hood until the steam has subsided. The engine compartment may be very hot.
- After the hybrid system has been turned off, check that the “READY” indicator is off. When the hybrid system is operating, the gasoline engine may automatically start, or the cooling fan may suddenly operate even if the gasoline engine stops. Do not touch or approach rotating parts such as the fan, which may lead to fingers or clothing (especially a tie, a scarf or a muffler) getting caught, resulting in serious injury.
- Do not loosen the coolant reservoir cap while the hybrid system and radiator are hot. High temperature steam or coolant could spray out.



NOTICE

■ **When adding engine/power control unit coolant**

Add coolant slowly after the hybrid system has cooled down sufficiently. Adding cool coolant to a hot hybrid system too quickly can cause damage to the hybrid system.

■ **To prevent damage to the cooling system**

Observe the following precautions:

- Avoid contaminating the coolant with foreign matter (such as sand or dust, etc.).
- Do not use any coolant additive.

If the vehicle becomes stuck

Carry out the following procedures if the tires spin or the vehicle becomes stuck in mud, dirt or snow:

Recovering procedure

- 1 Stop the hybrid system. Set the parking brake and shift the shift lever to P.
- 2 Remove the mud, snow or sand from around the stuck tire.
- 3 Place wood, stones or some other material to help provide traction under the tires.
- 4 Restart the hybrid system.
- 5 Shift the shift lever to D or R and release the parking brake. Then, while exercising caution, depress the accelerator pedal.

■ **When it is difficult to free the vehicle**

Press  OFF to turn off TRC. (→P.394)

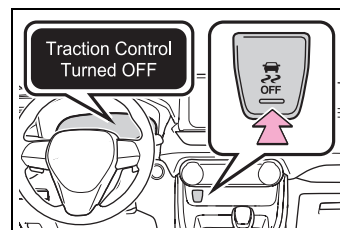



WARNING

■ **When attempting to free a stuck vehicle**

If you choose to push the vehicle back and forth to free it, make sure the surrounding area is clear to avoid striking other vehicles, objects or people. The vehicle may also lunge forward or lunge back suddenly as it becomes free. Use extreme caution.

■ **When shifting the shift lever**

Be careful not to shift the shift lever with the accelerator pedal depressed.

This may lead to unexpected rapid acceleration of the vehicle that may cause an accident resulting in death or serious injury.



NOTICE

■ **To avoid damaging the transmission and other components**

- Avoid spinning the wheels and depressing the accelerator pedal more than necessary.
- If the vehicle remains stuck even after these procedures are performed, the vehicle may require towing to be freed.

Vehicle specifications**9****9-1. Specifications**

- Maintenance data (fuel, oil level, etc.)546
- Fuel information554

9-2. Customization

- Customizable features555

9-3. Initialization

- Items to initialize567

Maintenance data (fuel, oil level, etc.)

Dimensions

Overall length*		4635 mm (182.5 in.)
Overall width*		1855 mm (73.0 in.)
Overall height*		1690 mm (66.5 in.)
Wheelbase*		2690 mm (105.9 in.)
Tread*	Front	1595 mm (62.8 in.)
	Rear	1615 mm (63.6 in.)

*: Unladen vehicle

Weights

Gross vehicle mass		2510 kg (5534 lb.)
Maximum permissible axle capacity	Front	1265 kg (2789 lb.)
	Rear	1315 kg (2899 lb.)
Drawbar load		70 kg (154 lb.)
Towing capacity	Without brake	750 kg (1653 lb.)
	With brake	1500 kg (3307 lb.)

Vehicle identification

■ **Vehicle identification number**

The vehicle identification number (VIN) is the legal identifier for your vehicle. This is the primary identification number for your vehicle. It is used in registering the ownership of your vehicle.

On some models, this number is stamped on the top left of the instrument panel.

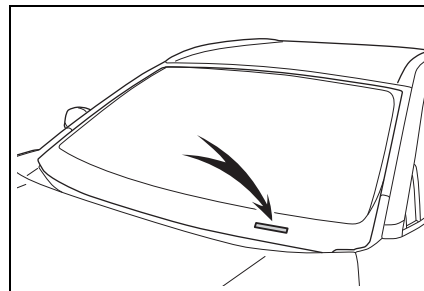

This number is also on the manufacturer's label.

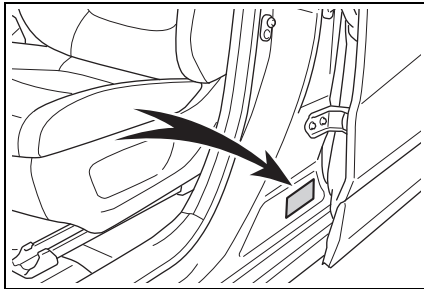

This number is also stamped under the right-hand front seat.

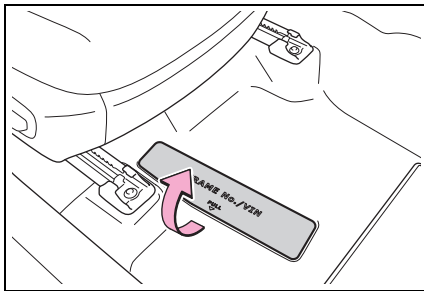

■ **Engine number**

The engine number is stamped on the engine block as shown.

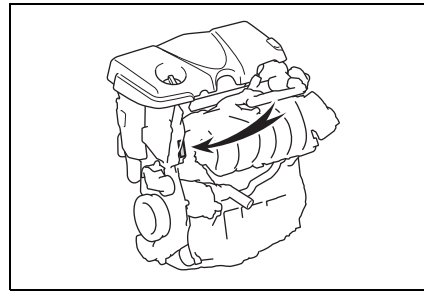

Engine	
Model	A25A-FXS
Type	4-cylinder in line, 4-cycle, gasoline
Bore and stroke	87.50×103.48 mm (3.44×4.07 in.)
Displacement	2487 cm ³ (151.8 cu. in.)
Valve clearance	Automatic adjustment

Fuel	
Fuel type	<p>When you find these types of fuel label at the gas station, use only the fuel with one of the following labels.</p> <div style="text-align: center;">  </div> <p>EU area: Unleaded gasoline conforming to European standard EN228 only</p> <p>Except EU area: Unleaded gasoline only</p>
Research Octane Number	<p>EU area: 95 or higher</p> <p>Except EU area: 91 or higher</p>
Fuel tank capacity (Reference)	55 L (14.5 gal., 12.1 Imp.gal.)

Electric motor (traction motor)

► Front

Type	Permanent magnet synchronous motor
Maximum output	134 kW
Maximum torque	270 N•m (27.5 kgf•m, 199 ft•lbf)

► Rear

Type	Permanent magnet synchronous motor
Maximum output	40 kW
Maximum torque	121 N•m (12.3 kgf•m, 89.2 ft•lbf)

Hybrid battery (traction battery)

Type	Lithium-ion battery
Voltage	3.7 V/cell
Capacity	51 Ah
Quantity	96 cells
Nominal voltage	355.2 V

Lubrication system

■ **Oil capacity (Drain and refill — reference*)**

With filter	4.5 L (4.8 qt., 4.0 Imp. qt.)
Without filter	4.2 L (4.4 qt., 3.7 Imp. qt.)

*: The engine oil capacity is a reference quantity to be used when changing the engine oil. Warm up the engine and turning off the hybrid system, wait more than 5 minutes, and check the oil level on the dipstick.

■ **Engine oil selection**

“SUZUKI GENUINE OIL” is used in your Suzuki vehicle. Suzuki recommends the use of approved “SUZUKI GENUINE OIL”. Another motor oil of matching quality can also be used.

Oil grade:

0W-16:

API grade SN multigrade engine oil

0W-20 and 5W-30:

API grade SL, SM, SN; or ILSAC multigrade engine oil

Recommended viscosity (SAE):

SAE 0W-16 is filled into your Suzuki vehicle at manufacturing, and the best choice for good fuel economy and good starting in cold weather.

If SAE 0W-16 oil is not available, SAE 0W-20 oil may be used. However, it should be replaced with SAE 0W-16 at the next oil change.

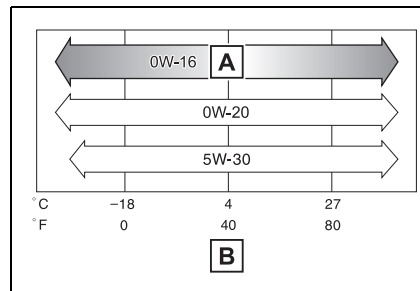

A Preferred

B Temperature range anticipated before next oil change

Oil viscosity (0W-16 is explained here as an example):

- The 0W in 0W-16 indicates the characteristic of the oil which

allows cold startability. Oils with a lower value before the W allow for easier starting of the engine in cold weather.

- The 16 in 0W-16 indicates the viscosity characteristic of the oil when the oil is at high temperature. An oil with a higher viscosity (one with a higher value) may be better suited if the vehicle is operated at high speeds, or under extreme load conditions.

How to read oil container labels:

Either or both API registered marks are added to some oil containers to help you select the oil you should use.

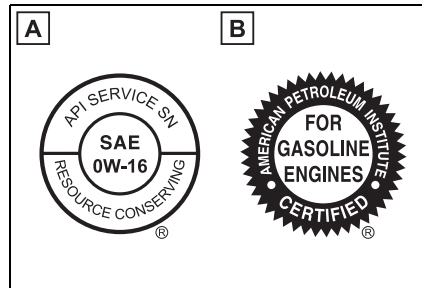

A API Service Symbol

Top portion: “API SERVICE SN” means the oil quality designation by American Petroleum Institute (API).

Center portion: “SAE 0W-16” means the SAE viscosity grade.

Lower portion: “Resource-Conserving” means that the oil has fuel-saving and environmental protection capabilities.

B ILSAC Certification Mark

The International Lubricant Specification Advisory Committee (ILSAC) Certification Mark is displayed on the front of the container.

Cooling system

Capacity*	Gasoline engine	7.4 L (7.8 qt., 6.5 Imp. qt.)
	Power control unit	2.0 L (2.1 qt., 1.8 Imp. qt.)
Coolant type	Use either of the following: <ul style="list-style-type: none"> • “Toyota Super Long Life Coolant” • Similar high-quality ethylene glycol-based non-silicate, non-amine, non-nitrite, and non-borate coolant with long-life hybrid organic acid technology Do not use plain water alone.	

*: The coolant capacity is the quantity of reference.

If replacement is necessary, contact a SUZUKI dealer or a qualified workshop.

Ignition system (spark plug)

Make	DENSO FC16HR-Q8
Gap	0.8 mm (0.031 in.)

 NOTICE**■ Iridium-tipped spark plugs**

Use only iridium-tipped spark plugs. Do not adjust the spark plug gap.

Electrical system (12-volt battery)

Specific voltage reading at 20°C (68°F):		12.0 V or higher (Turn the power switch to OFF and turn on the high beam headlights for 30 seconds.) If the voltage is lower than the standard value, charge the 12-volt battery.
Charging rates	Quick charge	15 A max.
	Slow charge	5 A max.

Hybrid transmission

Fluid capacity*	4.4 L (4.6 qt., 3.9 Imp.qt.)
Fluid type	Toyota Genuine ATF WS

*: The fluid capacity is the quantity of reference.
If replacement is necessary, contact a SUZUKI dealer or a qualified workshop.

 NOTICE**■ Hybrid transmission fluid type**

Using transmission fluid other than the above type may cause abnormal noise or vibration, or ultimately damage the transmission of your vehicle.

Rear differential (rear electric motor)

Fluid capacity*	1.7 L (1.8 qt., 1.5 Imp.qt.)
Fluid type	Toyota Genuine ATF WS

*: The fluid capacity is the quantity of reference.
If replacement is necessary, contact a SUZUKI dealer or a qualified workshop.

	NOTICE
<p>■ Rear differential fluid type</p> <p>Using differential fluid other than the above type may cause abnormal noise or vibration, or ultimately damage the differential of your vehicle.</p>	

Brakes

Pedal clearance*	Left-hand drive vehicles	128 mm (5.0 in.) Min.
	Right-hand drive vehicles	95 mm (3.7 in.) Min.
Pedal free play		1.0 — 6.0 mm (0.04 — 0.24 in.)
Fluid type		SAE J1703 or FMVSS No. 116 DOT 3 SAE J1704 or FMVSS No. 116 DOT 4

*: Minimum pedal clearance when depressed with a force of 300 N (30.5 kgf, 67.4 lbf) while the hybrid system is operating.

Steering

Free play	Less than 30 mm (1.2 in.)
-----------	---------------------------

Tires and wheels

■ Full-size tire

Tire size		235/55R19 101V
Tire inflation pressure (Recommended cold tire inflation pressure)	Front	230 kPa (2.3 kgf/cm ² or bar, 33 psi)
	Rear	230 kPa (2.3 kgf/cm ² or bar, 33 psi)
Wheel size		19 × 7 1/2 J
Wheel nut torque		103 N•m (10.5 kgf•m, 76 ft•lbf)

■ **Compact spare tire**

Tire size	T165/90D18 107M
Tire inflation pressure (Recommended cold tire inflation pressure)	420 kPa (4.2 kgf/cm ² or bar, 60 psi)
Wheel size	18 × 4T
Wheel nut torque	103 N•m (10.5 kgf•m, 76 ft•lbf)

■ **When towing a trailer: →P.270**

Add 20.0 kPa (0.2 kgf/cm² or bar, 3 psi) to the recommended tire inflation pressure and drive at speeds below 100 km/h (62 mph).

Light bulbs

Light bulbs		W	Type
Exterior	Front fog lights	19	A
	Front turn signal lights	21	B
	Rear turn signal lights	21	B
	Back-up lights	16	C
	Outer foot lights	5	C
Interior	Vanity lights	8	C
	Front interior lights/personal lights	5	C
	Rear interior light	8	D
	Luggage compartment light	5	C

- A: H16 halogen bulbs
- B: Wedge base bulbs (amber)
- C: Wedge base bulbs (clear)
- D: Double end bulbs

Fuel information

When you find these types of fuel label at the gas station, use only the fuel with one of the following labels.



EU area:

You must only use unleaded gasoline conforming to European standard EN228.

Select unleaded gasoline with a Research Octane Number of 95 or higher for optimum engine performance.

Except EU area:

You must only use unleaded gasoline.

Select unleaded gasoline with a Research Octane Number of 91 or higher for optimum engine performance.

■ Use of ethanol blended gasoline in a gasoline engine

Suzuki allows the use of ethanol blended gasoline where the ethanol content is up to 10%. Make sure that the ethanol blended gasoline to be used has a Research Octane Number that follows the above.

■ If your engine knocks

- Consult a SUZUKI dealer or a qualified workshop.

- You may occasionally notice light knocking for a short time while accelerating or driving uphill. This is normal and there is no need for concern.

⚠ NOTICE

■ Notice on fuel quality

- Do not use improper fuels. If improper fuels are used, the engine will be damaged.
- Do not use gasoline with metallic additives, for example manganese, iron or lead, otherwise it may cause damage on your engine or emission control system.
- Do not add aftermarket fuel additives which contain metallic additives.
- EU area: Bioethanol fuel sold under names such as "E50" or "E85" and fuel containing a large amount of ethanol should not be used. The use of these fuels will damage the vehicle's fuel system. In case of any doubt, ask a SUZUKI dealer or a qualified workshop.
- Except EU area: Bioethanol fuel sold under names such as "E50" or "E85" and fuel containing a large amount of ethanol should not be used. Your vehicle can use gasoline mixed with 10% max ethanol. The use of fuel with more than 10% ethanol content (E10) will damage the vehicle's fuel system. You must ensure that refueling is carried out only from a source where fuel specification and quality can be guaranteed. In case of any doubt, ask a SUZUKI dealer or a qualified workshop.
- Do not use the methanol blended gasoline such as M15, M85, M100. The use of gasoline containing methanol may cause engine damage or failure.

Customizable features

Your vehicle includes a variety of electronic features that can be personalized to suit your preferences. The settings of these features can be changed using the multi-information display, multimedia system, or at a SUZUKI dealer or a qualified workshop.







Customizing vehicle features

■ Changing using the multimedia system

- 1 Press the "MENU" button.
- 2 Select "Setup" on the menu screen and select "Vehicle".
- 3 Select "Vehicle Customization".

Various setting can be changed. Refer to the list of settings that can be changed for details.

■ Changing using the multi-information display

- 1 Press  or  of the meter control switches and select .
- 2 Press  or  of the meter control switches, select the item.
- 3 To switch the function on and off, press  to switch to the desired setting.
- 4 To perform detailed setting of functions that support detailed

settings, press and hold  and display the setting screen.

The method of performing detailed setting differs for each screen. Please refer to the advice sentence displayed on the screen.

To go back to the previous screen or exit the customize mode, press .

■ When customizing using the multimedia system or multi-information display

Stop the vehicle in a safe place, apply the parking brake, and shift the shift lever to P. Also, to prevent 12-volt battery discharge, leave the hybrid system operating while customizing the features.

WARNING

■ During customization

As the hybrid system needs to be operating during customization, ensure that the vehicle is parked in a place with adequate ventilation. In a closed area such as a garage, exhaust gases including harmful carbon monoxide (CO) may collect and enter the vehicle. This may lead to death or a serious health hazard.

NOTICE

■ During customization

To prevent 12-volt battery discharge, ensure that the hybrid system is operating while customizing features.

Customizable Features

Some function settings are changed simultaneously with other functions being customized. Contact a SUZUKI dealer or a qualified workshop for further details.

A Settings that can be changed using the multimedia system

B Settings that can be changed using the multi-information display

C Settings that can be changed by a SUZUKI dealer or a qualified workshop

Definition of symbols: O = Available, – =Not available

■ Alarm (→P.73)

Function	Default setting	Customized setting	A	B	C
Deactivates the alarm when the doors are unlocked using the mechanical key	Off	On	–	–	O

■ Charging system (→P.118, 121)

Function	Default setting	Customized setting	A	B	C
“Charging Current”	MAX	8A	–	O	–
“Battery Heater”	On	Off	–	O	–
“Battery Cooler”	On	Off	–	O	–

■ Gauges, meters and multi-information display (→P.166, 171)

Function *1	Default setting	Customized setting	A	B	C
Language *2	“English” (English)	Except English *3	–	O	–
Units *2	km (L/100km, kWh/100km)	km (km/L, km/kWh)	–	O	–
		miles (MPG, miles/kWh) *4	–	O	–
Speedometer display	Analog	Digital	–	O	–
EV indicator	On	Off	–	O	–

Function *1	Default setting	Customized setting	A	B	C
“Eco Guidance” (ECO Accelerator Guidance)	On	Off	–	O	–
“Fuel Economy”	“Total Average”	“Trip Average”	–	O	–
		“Tank Average”			
“Power Consumption”	“Total Average”	“Trip Average”	–	O	–
Audio system linked display	On	Off	–	O	–
Energy monitor	On	Off	–	O	–
AWD system display	On	Off	–	O	–
Drive information type	Trip	Total	–	O	–
Drive information items (first item)	Distance	Average Speed	–	O	–
		Total Time			
Drive information items (second item)	Total Time	Average Speed	–	O	–
		Distance			
“Closing Display”	“ECO Score”	“Drive Info”	–	O	–
		“Charging Schedule”			
Pop-up display	On	Off	–	O	–
Calendar *5	–	–	–	O	–
Multi-Information display off	Off	On	–	O	–
Suggestion function	On	On (when the vehicle is stopped)	O	–	O
		Off			

*1: For details about each function: →P.177

*2: The default setting varies according to country.

*3: Available languages may differ depending on the target region.

*4: If equipped

*5: This can only be set if GPS calibration of clock is turned off in the multimedia system settings.

■ Door lock (→P.191, 533)

Function	Default setting	Customized setting	A	B	C
Unlocking using a mechanical key	All doors unlocked in first step	Driver's door unlocked in first step, all doors unlocked in second step	-	-	O
Speed linked door locking function	On	Off	O	-	O
Shift position linked door locking function	Off	On	O	-	O
Shift position linked door unlocking function	Off	On	O	-	O
Driver's door linked door unlocking function	On	Off	O	-	O

■ Smart entry & start system and wireless remote control (→P.189, 206)

Function	Default setting	Customized setting	A	B	C
Time elapsed before the automatic door lock function is activated if a door is not opened after being unlocked	30 seconds	60 seconds	-	-	O
		120 seconds			
Open door reminder buzzer (When locking the vehicle)	On	Off	-	-	O

■ Smart entry & start system (→P.206)

Function	Default setting	Customized setting	A	B	C
Smart entry & start system	On	Off	O	-	O
Smart door unlocking	All the doors	Driver's door	O	-	O

Function	Default setting	Customized setting	A	B	C
Number of consecutive door lock operations	2 times ^{*1}	As many as desired ^{*1}	-	-	O
	As many as desired ^{*2}	2 times ^{*2}	-	-	O
Time elapsed before unlocking all the door when gripping and holding the driver's door handle ^{*3}	Off	1.5 seconds	-	-	O
		2 seconds	-	-	O
		2.5 seconds	-	-	O
Power switch illumination	On	Off	-	-	O

^{*1}: For vehicles without double locking system

^{*2}: For vehicles with double locking system

^{*3}: This setting can be changed when the smart door unlocking setting is set to Driver's door.

■ Wireless remote control (→P.189)

Function	Default setting	Customized setting	A	B	C
Wireless remote control	On	Off	-	-	O
Unlocking operation	All doors unlocked in first step	Driver's door unlocked in first step, all doors unlocked in second step	O	-	O
The function that activates the  switch of the wireless remote control when locking the door (→P.197)	Off	On (Unlocking all the door)	-	-	O
		On (Unlocking back door only)	-	-	O

■ Rear seat reminder function (→P.193)

Function	Default setting	Customized setting	A	B	C
Rear seat reminder function	On	Off	-	O	-

■ Power back door (→P.195)

Function	Default setting	Customized setting	A	B	C
Power back door operations	On	Off	-	O	-
Back door opener switch operations	Press and hold	One short press	-	-	O
 switch of the wireless remote control operation	Off	One short press	-	-	O
		Push twice			
		Press and hold			
Operation buzzer volume	3	1	-	O	-
		2			
Operation buzzer while the back door is operating ^{*1}	Off	On	-	-	O
Opening angle	5	1 to 4	-	O	-
		User setting ^{*2}			
Power back door open operation when the back door opener switch is pressed	On	Off	-	-	O
Back door closing assist	On	Off	-	-	O
Hands Free Power Back Door ^{*3}	On	Off	-	O	O

*1: The operation buzzer that sounds when the back door begins to operate cannot be turned off. (→P.197)

*2: The open position is set by the power back door switch. (→P.205)

*3: When the towing hitch is installed, Hands Free Power Back Door does not work.

■ Outside rear view mirrors (→P.256)

Function	Default setting	Customized setting	A	B	C
Automatic folding and extending operation	Linked to locking/unlocking of the doors	Off	-	-	O
		Linked to power switch operation			

■ **Power windows (→P.258)**

Function	Default setting	Customized setting	A	B	C
Key linked operation (open)	Off	On	-	-	O
Key linked operation (close)	Off	On	-	-	O
Wireless remote control linked operation (open)	Off	On	-	-	O
Wireless remote control linked operation (close)	Off	On	-	-	O
Wireless remote control linked operation signal (buzzer)	On	Off	-	-	O
Side windows open warning function	On	Off	-	-	O
Sliding roof open warning function	On	Off	-	-	O

■ **Lights (→P.294)**

Function	Default setting	Customized setting	A	B	C
Light reminder buzzer	On	Off	-	-	O

■ **Automatic light control system (→P.294)**

Function	Default setting	Customized setting	A	B	C
Light sensor sensitivity	Standard	-2 to 2	O	-	O
Time elapsed before headlights automatically turn on	Standard	Long	-	-	O
Time elapsed before the headlights turn off (Extended Headlight Lighting)	30 seconds	60 seconds	-	-	O
		90 seconds			
		120 seconds			

■ Rear window wiper (→P.302)

Function	Default setting	Customized setting	A	B	C
Back door opening linked rear window wiper stop function	Off	On	-	-	O
Washer linked rear window wiper operation	On	Off	-	-	O
Shift position linked rear window wiper operation (→P.303)	Only once	Off	-	-	O
		Continuous	-	-	O

■ PCS (Pre-Collision System) (→P.316)

Function	Default setting	Customized setting	A	B	C
PCS (Pre-Collision System)	On	Off	-	O	-
Adjust alert timing	Middle	Early	-	O	-
		Late	-	O	-

■ LTA (Lane Tracing Assist) (→P.323)

Function	Default setting	Customized setting	A	B	C
Lane centering function	On	Off	-	O	-
Steering assist function	On	Off	-	O	-
Alert type	Steering wheel vibration	Buzzer	-	O	-
Alert sensitivity	High	Standard	-	O	-
Vehicle sway warning function	On	Off	-	O	-
Vehicle sway warning sensitivity	Standard	Low	-	O	-
		High	-	O	-

■ RSA (Road Sign Assist) (→P.333)

Function	Default setting	Customized setting	A	B	C
RSA (Road Sign Assist) ^{*1}	On	Off	-	O	-

Function	Default setting	Customized setting	A	B	C
Excess speed notification method*2	Display only	No notification		O	-
		Display and buzzer	-	O	-
Excess speed notification level	2 km/h (1 mph)	5 km/h (3 mph)	-	O	-
		10 km/h (5 mph)	-	O	-
No-overtaking notification method	Display only	No notification		O	-
		Display and steering wheel vibration	-	O	-

*1: RSA function becomes on when the power switch is turned to ON.

*2: If a Speed limit with supplemental mark is exceeded, the notification buzzer does not operate.

■ **Dynamic radar cruise control with full-speed range (→P.337)**

Function	Default setting	Customized setting	A	B	C
Dynamic Radar Cruise Control with Road Sign Assist	On	Off	-	O	-

■ **BSM (Blind Spot Monitor) (→P.349)**

Function	Default setting	Customized setting	A	B	C
BSM (Blind Spot Monitor)	On	Off	-	O	-
Outside rear view mirror indicator brightness	Bright	Dim	-	O	-
Alert timing for presence of approaching vehicle (sensitivity)	Intermediate	Early		O	-
		Late		O	-
		Only when vehicle detected in blind spot	-	O	-

■ RCTA (Rear crossing traffic alert) function (→P.349)

Function	Default setting	Customized setting	A	B	C
RCTA (Rear crossing traffic alert) function	On	Off	-	O	-
Buzzer volume*	Level 2	Level 1	-	O	-
		Level 3	-	O	-

*: This setting is linked with the buzzer volume of the parking assist-sensor.

■ Parking assist-sensor (→P.369)

Function	Default setting	Customized setting	A	B	C
Parking assist-sensor	On	Off	-	O	O
Buzzer volume*	2	1	-	O	O
		3	-	O	O

*: This setting is linked with the buzzer volume of the RCTA (Rear crossing traffic alert) function.

■ PKSB (Parking Support Brake) (→P.375)

Function	Default setting	Customized setting	A	B	C
PKSB (Parking Support Brake) function	On	Off	-	O	-

■ Automatic air conditioning system (→P.406)

Function	Default setting	Customized setting	A	B	C
Switching between outside air and recirculated air mode linked to "AUTO" switch operation	On	Off	O	-	O
A/C Auto switch operation	On	Off	O	-	O
Switching to the outside air mode when the vehicle is parked	On	Off	-	-	O

■ Remote Air Conditioning System (→P.413)

Function	Default setting	Customized setting	A	B	C
Operation using the "A/C" button on the wireless remote control	Press and hold (short)	Press once	-	-	O
		Press twice			
		Press and hold (long)			
		Off			
Stopping operation using the "A/C" button on the wireless remote control	Press twice	Press once	-	-	O
		Press and hold (short)			
		Press and hold (long)			
		Off			

■ Illumination (→P.417)

Function	Default setting	Customized setting	A	B	C
Time elapsed before the interior lights turn off	15 seconds	Off	O	-	O
		7.5 seconds			
		30 seconds			
Operation after the power switch is turned off	On	Off	-	-	O
Operation when the doors are unlocked	On	Off	-	-	O
Operation when you approach the vehicle with the electronic key on your person	On	Off	-	-	O
Footwell lighting	On	Off	-	-	O

■ Vehicle customization

- When the speed linked door locking function and shift position linked door locking function are both on, the door lock operates as follows.
- If the vehicle is started with all the doors locked, the speed linked door locking function would not operate.
- If the vehicle is started with any door unlocked, the speed linked door locking function will operate.

566 **9-2. Customization**

- When shifting the shift lever to any position other than P, all the doors will be locked.
- When the smart entry & start system is off, the selecting door to unlock cannot be customized.
- When the doors remain closed after unlocking the doors and the automatic door lock function is activated, the signals will be generated in accordance with the Operation signal (emergency flashers) settings.

Items to initialize

The following items must be initialized for normal system operation after such cases as the 12-volt battery being reconnected, or maintenance being performed on the vehicle:

List of the items to initialize

Item	When to initialize	Reference
Power back door	<ul style="list-style-type: none"> • After reconnecting or changing the 12-volt battery • After changing a fuse 	P.202
Power windows	<ul style="list-style-type: none"> • When functioning abnormally 	P.258
Tire pressure warning system	<ul style="list-style-type: none"> • When rotating the tires • When changing the tire • After registering the ID codes 	P.465
Parking assist monitor	<ul style="list-style-type: none"> • After reconnecting or changing the 12-volt battery • After changing a fuse 	Refer to "Multimedia Owner's Manual"

Index

569

What to do if... (Troubleshooting)**570**
Alphabetical Index**573**

What to do if... (Troubleshooting)

If you have a problem, check the following before contacting a SUZUKI dealer or a qualified workshop.

The doors cannot be locked, unlocked, opened or closed



You lose your keys

- If you lose your mechanical keys, new genuine mechanical keys can be made by a SUZUKI dealer or a qualified workshop. (→P.531)
- If you lose your electronic keys, the risk of vehicle theft increases significantly. Contact a SUZUKI dealer or a qualified workshop immediately. (→P.531)



The doors cannot be locked or unlocked

- Is the key battery weak or depleted? (→P.484)
- Is the power switch in ON?
When locking the doors, turn the power switch off. (→P.282)
- Is the electronic key left inside the vehicle?
When locking the doors, make sure that you have the electronic key on your person.
- The function may not operate

properly due to the condition of the radio wave. (→P.208)



The rear door cannot be opened

- Is the child-protector lock set?
The rear door cannot be opened from inside the vehicle when the lock is set. Open the rear door from outside and then unlock the child-protector lock. (→P.194)

If you think something is wrong



The hybrid system does not start

- Did you press the power switch while firmly depressing the brake pedal? (→P.279)
- Is the shift lever in P? (→P.279)
- Is the electronic key anywhere detectable inside the vehicle? (→P.207)
- Is the steering wheel unlocked? (→P.280)
- Is the electronic key battery weak or depleted?
In this case, the hybrid system can be started in a temporary way. (→P.534)
- Is the 12-volt battery discharged? (→P.535)



The shift lever cannot be shifted from P even if you depress the brake pedal

- Is the power switch in ON? If you cannot release the shift lever by depressing the brake pedal with the power switch in ON. (→P.285)



The steering wheel cannot be turned after the hybrid system is stopped

- It is locked automatically to prevent theft of the vehicle. (→P.280)



The windows do not open or close by operating the power window switches

- Is the window lock switch pressed?
The power window except for the one at the driver's seat cannot be operated if the window lock switch is pressed. (→P.260)



The power switch is turned off automatically

- The auto power off function will be operated if the vehicle is left in ACC or ON (the hybrid system is not operating) for a period of time. (→P.282)



A warning buzzer sounds during driving

- The seat belt reminder light is

flashing

Are the driver and the passengers wearing the seat belts? (→P.515, 516)

- The parking brake indicator is on
Is the parking brake released? (→P.288)

Depending on the situation, other types of warning buzzer may also sound. (→P.508, 518)



An alarm is activated and the horn sounds

- Did anyone inside the vehicle open a door during setting the alarm?
The sensor detects it and the alarm sounds. (→P.73)

To stop the alarm, turn the power switch to ON or start the hybrid system.



A warning buzzer sounds when leaving the vehicle

- Is the message displayed on the multi-information display?
Check the message on the multi-information display. (→P.518)



A warning light turns on or a warning message is displayed

- When a warning light turns on or a warning message is displayed, refer to P.508, 518.

When a problem has occurred



If you have a flat tire

- Stop the vehicle in a safe place and replace the flat tire with the spare tire. (→P.522)



The vehicle becomes stuck

- Try the procedure for when the vehicle becomes stuck in mud, dirt, or snow. (→P.543)

Alphabetical Index

A

A/C

- “My Room Mode” 145
- Air conditioning filter..... 473
- Automatic air conditioning system
..... 406
- Blower customization 408
- Front seat concentrated airflow
mode (S-FLOW) 411
- Humidity sensor 413
- Remote Air Conditioning System 413
- ABS (Anti-lock Brake System) 392**
- Function 392
- Warning light 510
- ACA (Active Cornering Assist).... 393**
- AC charging cable 102**
- AC charging cable types 104
- CCID (Charging Circuit Interrupting
Device) 103
- If the charging connector cannot be
unlocked 116
- Indicator 107
- Locking and unlocking 115
- Maintenance 110
- Replacing the plug-cord 108
- Safety functions 106
- Acoustic Vehicle Alerting System. 87**
- Active Cornering Assist (ACA).... 393**
- Airbag manual on-off system 46**
- Airbags 37**
- Airbag manual on-off system 46
- Airbag operating conditions 39
- Airbag precautions for your child . 41
- Airbag warning light 510
- Correct driving posture..... 31
- Curtain shield airbag operating con-
ditions 39
- Curtain shield airbag precautions 41
- General airbag precautions..... 41
- Locations of airbags 37

- Modification and disposal of airbags
..... 44
- Side airbag operating conditions.. 39
- Side airbag precautions 41
- Side and curtain shield airbags oper-
ating conditions 39
- Side and curtain shield airbags pre-
cautions..... 41
- SRS airbags 37
- SRS warning light..... 510
- Air conditioning filter 473**
- Air conditioning system**
- “My Room Mode” 145
- Air conditioning filter..... 473
- Automatic air conditioning system
..... 406
- Blower customization 408
- Front seat concentrated airflow
mode (S-FLOW)..... 411
- Humidity sensor 413
- Remote Air Conditioning System 413
- Air intake vent 92**
- Cleaning 477
- Alarm..... 73**
- Alarm..... 73
- Warning buzzer 508
- Antenna**
- Smart entry & start system 206
- Anti-lock brake system (ABS) 392**
- Function 392
- Warning light 510
- Approach warning 344**
- Armrest 429**
- Assist grips 429**
- AUTO EV/HV mode 79**
- AUTO EV/HV mode switch 80**
- Automatic air conditioning system
..... 406**
- “My Room Mode” 145
- Air conditioning filter..... 473
- Blower customization 408

Front seat concentrated airflow mode (S-FLOW) 411
 Humidity sensor 413
 Remote Air Conditioning System 413
Automatic headlight leveling system **294**
Automatic High Beam (AHB) **296**
Automatic light control system... **294**
Auxiliary box **423**

B

Back door **195**
 Hands Free Power Back Door ... 198
 Power back door 197
 Wireless remote control 197
Back-up lights
 Replacing light bulbs 489
 Wattage 553
Battery (12-volt battery) **450**
 If the 12-volt battery is discharged 535
 Preparing and checking before winter 399
 Replacing 537
 Warning light 508
Battery (traction battery)..... **88**
 Charging 128
 Location 88
 Specification 549
Blind Spot Monitor (BSM) **349**
 Blind Spot Monitor function 363
 Rear Crossing Traffic Alert function 366
Bottle holders **422**
Brake
 Brake Hold 291
 Parking brake 288
 Regenerative braking 84
 Warning light 508
Brake assist **392**
Brake Hold **291**

Brake Override System **263**
Break-in tips **263**
BSM (Blind Spot Monitor) **349**
 Blind Spot Monitor function 363
 Rear Crossing Traffic Alert function 366

C

Card holder..... **423**
Care
 Aluminum wheels 432
 Exterior 432
 Front camera 307
 Interior 435
 Radar sensor 306
 Seat belts 435
Cargo hooks..... **424**
Chains..... **400**
Charging
 “My Room Mode” 145
 AC charging cable 102
 Charging equipment 99
 Charging indicator 101
 Charging messages 152
 Charging precautions 131
 Charging procedure 128
 Charging schedule function 136
 Charging time may increase 121
 High voltage components 88
 How to charge 128
 Information related to charging display 124
 Opening and closing the charging port lid 100
 Power sources precautions 118
 Power sources that can be used 117
 Safety functions 125, 131
 When charging cannot be carried out 148
Charging port **99**

If the charging port lid does not open 114
 Locking and unlocking 114
 Opening and closing 100
Child-protector..... 194
Child restraint system..... 48
 Child restraint system installation
 method..... 56
 Fixed with a seat belt 57
 Fixed with an ISOFIX lower anchorage..... 59
 Points to remember..... 48
 Riding with children 47
 Using a top tether anchorage..... 60
Child safety 47
 12-volt battery precautions. 450, 538
 Airbag precautions 41
 Back door precautions 195
 Charging precautions..... 125
 Heated steering wheel and seat
 heater precautions 415
 How your child should wear the seat
 belt..... 34
 Power window lock switch 260
 Power window precautions 259
 Rear door child-protectors 194
 Removed key battery precautions
 485
 Seat belt precautions 33
 Seat heater precautions 415
Cleaning 432, 435
 Aluminum wheels..... 432
 DC/DC Converter air intake vent..... 477
 Exterior..... 432
 Front camera..... 307
 Interior..... 435
 Radar sensor 306
 Seat belts 435
Clock..... 171
Coat hooks 430
Condenser..... 448

Console box 421
Consumption screen 182
Coolant
 Capacity 550
 Checking 447
 Preparing and checking before winter..... 399
 Warning light 509
Cooling system 447
 Hybrid system overheating..... 541
Cruise control
 Dynamic radar cruise control with
 full-speed range 337
Cup holders 422
Current fuel consumption..... 184
Current fuel economy..... 173
Curtain shield airbags 37
Customizable features 555

D

Daytime running light system 294
 Replacing light bulbs 489
DC/DC converter air intake vent.... 92
 Cleaning 477
Deck board 424
Deck under tray..... 425
Defogger
 Outside rear view mirrors 408
 Rear window 408
 Windshield..... 407
Dimensions 546
Display
 BSM (Blind Spot Monitor)..... 349
 Consumption screen 182
 Drive information 176
 Driving information 173
 Dynamic radar cruise control with
 full-speed range 337
 Energy monitor..... 182
 LTA (Lane-Tracing Assist) 329
 Multi-information display 171

Parking assist-sensor.....	369
Parking Support Brake function .	376
Pre-collision warning.....	316
RCTA.....	349
RSA (Road Sign Assist).....	333
Warning messages.....	518
Do-it-yourself maintenance .	438, 440
Door lock	
Back door.....	195
Side doors.....	191
Smart entry & start system.....	206
Wireless remote control.....	189
Doors	
Automatic door locking and unlock- ing system.....	195
Back door.....	195
Door glasses.....	258
Door lock.....	191
Open door warning buzzer.....	194
Outside rear view mirrors.....	256
Rear door child-protectors.....	194
Side doors.....	191
Double locking system.....	72
Drive information.....	176
Driver's seat belt reminder light..	515
Drive-start control.....	263
Driving	
Break-in tips.....	263
Correct posture.....	31
Driving mode select switch.....	388
Plug-in hybrid vehicle driving tips.	93
Procedures.....	262
Winter drive tips.....	399
Driving information display.....	173
Driving mode select switch.....	388
Driving support system information display.....	176
Dynamic radar cruise control with full-speed range	
Function.....	337
Warning message.....	518

E

eCall.....	62
ECB (Electronically Controlled Brake System).....	392
Eco drive mode.....	388
E-Four (Electronic On-Demand AWD system).....	393
Electric motor	
Location.....	78
Specification.....	548
Electric Power Steering (EPS)	
Function.....	393
Warning light.....	510
Electronically Controlled Brake Sys- tem (ECB).....	392
Electronic key	
Battery-saving function.....	207
If the electronic key does not operate properly.....	533
Replacing the battery.....	484
Emergency, in case of	
If a warning buzzer sounds.....	508
If a warning light turns on.....	508
If a warning message is displayed	518
If the 12-volt battery is discharged	535
If the electronic key does not operate properly.....	533
If the fuel filler door cannot be opened.....	532
If the hybrid system will not start	530
If the vehicle is trapped in rising water.....	501
If you have a flat tire.....	522
If you lose your keys.....	531
If you think something is wrong..	506
If your vehicle becomes stuck....	543
If your vehicle has to be stopped in an emergency.....	500

If your vehicle needs to be towed 503

If your vehicle overheats 540

Emergency brake signal 393

Emergency flashers 500

Energy monitor 182

Engine

 Compartment 445

 Exhaust gas precautions 45

 Hood 442

 How to start the hybrid system... 279

 Identification number 547

 If the hybrid system will not start 530

 If your vehicle has to be stopped in an emergency 500

 Overheating 540

 Power switch 279

Engine coolant

 Capacity 550

 Checking 447

 Oil pressure warning light 509

 Preparing and checking before winter 399

 Warning light 509

Engine oil

 Capacity 549

 Checking 445

 Preparing and checking before winter 399

 Warning light 509

EPS (Electric Power Steering)

 Function 393

 Warning light 510

EV/HV mode selection switch 80

EV driving range 96

EV mode 79

Exhaust gas precautions 45

Extended Headlight Lighting system 295

F

Flat tire 522

 Tire pressure warning system 454

Floor mats 30

Fluid

 Brake 552

 Hybrid transmission 551

 Rear differential 551

 Washer 449

Fog lights

 Replacing light bulbs 489

 Switch 299

 Wattage 553

Footwell lights 417

Front fog lights

 Replacing light bulbs 489

 Switch 299

 Wattage 553

Front passenger's seat belt reminder light 515

Front position lights

 Light switch 294

 Replacing light bulbs 489

Front seat concentrated airflow mode (S-FLOW) 411

Front seat heaters 415

Front seats 249

 Adjustment 249

 Cleaning 435

 Correct driving posture 31

 Head restraints 252

 Seat heaters 415

Front turn signal lights

 Replacing light bulbs 489

 Turn signal lever 287

 Wattage 553

Fuel

 Capacity 548

 Fuel gauge 166

 Gas station information 591

Information 554
 Refueling 304
 Type 548
 Warning light 515
Fuel consumption information
 Average fuel consumption 184
 Current fuel consumption 184
Fuel filler door 305
 If the fuel filler door cannot be
 opened 532
 Opener 305
 Refueling 304
Fuses 486

G

Gas station information 591
Glove box 421
**GPF (Gasoline Particulate Filter)
 system 391**

H

Headlight cleaner 300
Headlights 294
 Automatic headlight leveling 294
 Automatic High Beam (AHB) 296
 Extended Headlight Lighting system
 295
 Light switch 294
 Replacing light bulbs 489
Head restraints 252
Heated steering wheel 415
Heaters
 Automatic air conditioning system
 406
 Heated steering wheel 415
 Hybrid battery (traction battery) . 121
 Outside rear view mirrors 408
 Seat heaters 415
**High coolant temperature warning
 light 509**

High mounted stoplight
 Replacing light bulbs 489
High voltage components 88
Hill-start assist control 393
Hood 442
 Warning message 518
Hooks
 Cargo hooks 424
 Coat hooks 430
 Retaining hooks (floor mat) 30
Horn 254
HV mode 79
Hybrid battery (traction battery)
 Charging 128
 Location 88
 Specification 549
**Hybrid battery (traction battery)
 charge mode 79**
Hybrid system
 ACCESSORY mode 282
 Acoustic Vehicle Alerting System . 87
 Brake Override System 263
 Drive-Start Control 263
 Emergency shut off system 92
 Energy monitor/consumption screen
 182
 High voltage components 88
 How to start the hybrid system ... 279
 Hybrid System Indicator 166
 If the hybrid system will not start 530
 If your vehicle has to be stopped in
 an emergency 500
 Ignition switch (power switch) 279
 Overheating 540
 Plug-in hybrid system precautions 88
 Plug-in hybrid vehicle driving tips . 93
 Power (ignition) switch 279
 Regenerative braking 84
 Starting the hybrid system 279
Hybrid System Indicator 166
Hybrid transmission 283

I

Identification
 Engine 547
 Vehicle 546
Ignition switch (power switch) 279
 Auto power off function 282
 Changing the power switch modes
 282
 If your vehicle has to be stopped in
 an emergency 500
 Starting the hybrid system 279
Illuminated entry system 418
Immobilizer system 71
Indicators 160
Initialization
 Items to initialize 567
 Power back door 202
 Power windows 258
 Tire pressure warning system 465
Inside rear view mirror 255
Instrument cluster light control .. 170
Interior lights 417
 Switch 418
 Wattage 553
Intrusion sensor 74
ISOFIX lower anchorages 59

J

Jack
 Positioning a floor jack 443
 Vehicle-equipped jack 523
Jack handle 523
Jam protection function
 Power back door opener and closer
 200
 Power windows 258

K

Keyless entry

Smart entry & start system 206
 Wireless remote control 189
Keys 188
 Battery-saving function 207
 Electronic key 188
 If the electronic key does not operate
 properly 533
 If you lose your keys 531
 Key number plate 188
 Keyless entry 189, 206
 Mechanical key 190
 Power switch 279
 Replacing the battery 484
 Warning buzzer 207
 Wireless remote control key 189
Knee airbags 37

L

Lane Tracing Assist (LTA) 323
 Operation 323
 Warning messages 332
Language (multi-information display) 180, 556
Lever
 Auxiliary catch lever 442
 Hood lock release lever 442
 Shift lever 283
 Tilt and telescopic steering lock
 release lever 254
 Turn signal lever 287
 Wiper lever 300, 302
License plate lights
 Light switch 294
 Replacing light bulbs 489
Light bulbs
 Replacing 489
 Wattage 553
Lights
 Automatic High Beam system 296
 Emergency flasher switch 500

Extended Headlight Lighting system 295
 Fog light switch 299
 Front interior lights 418
 Headlight switch 294
 Illuminated entry system 418
 Interior lights 418
 Luggage compartment light 199
 Personal lights 418
 Rear interior light 418
 Replacing light bulbs 489
 Turn signal lever 287
 Vanity lights 427
 Wattage 553
LTA (Lane Tracing Assist) 323
 Operation 323
 Warning messages 332
Luggage compartment light 199
 Wattage 553
Luggage cover 425

M

Maintenance
 Do-it-yourself maintenance 440
 Maintenance data 546
 Maintenance requirements 438
Malfunction indicator lamp 509
Menu icons 172
Meter
 “ODO TRIP” switch 170
 Clock 171
 Indicators 160
 Meter control switches 172
 Multi-information display 171
 Settings 177, 556
 Units 180, 556
 Warning lights 508
 Warning messages 181, 518
Meter control switches 172
Mirrors
 Inside rear view mirror 255

Outside rear view mirror defoggers 408
 Outside rear view mirrors 256
 Vanity mirrors 427
Multi-information display
 Audio system-linked display 176
 BSM (Blind Spot Monitor) 349
 Changing the display 172
 Display contents 171
 Driving information display 173
 Driving support system information display 176
 Dynamic radar cruise control with full-speed range 337
 Energy monitor/consumption screen 182
 Hybrid System Indicator 169
 Language 180, 556
 LTA (Lane-Tracing Assist) .. 329, 556
 Menu icons 172
 Meter control switches 172
 Parking assist-sensor 369
 Parking Support Brake function .376
 PCS (Pre-Collision System) 316
 Pop-up display 180
 RSA (Road Sign Assist) 333
 Settings 177, 556
 Suggestion function 181
 Units 180, 556
 Vehicle information display 176
 Warning message display 181
 Warning messages 518
“My Room Mode” 145

N

Normal mode 388

O

Odometer 166
 “ODO TRIP” switch 170

“ODO TRIP” switch 170

Oil

 Engine oil 549

Opener

 Back door 197

 Fuel filler door 305

 Hood 442

Outer foot lights

 Replacing light bulbs 489

 Wattage 553

Outside rear view mirrors 256

 Adjusting and folding 256

 BSM (Blind Spot Monitor) 349

 Outside rear view mirror defoggers
 408

Outside temperature display 169

Overheating 540

P

Paddle shift switches 285

Parking assist-sensor 369

 Function 369

 Warning message 371

**Parking assist sensors (Parking
assist-sensor) 369**

Parking brake

 Operation 288

 Parking brake engaged warning
 buzzer 290

 Warning light 514

 Warning message 290

Parking Support Brake (PKSB) ... 375

 Indicator 163

 Parking Support Brake function
 (rear-crossing vehicles) 384

 Parking Support Brake function
 (static objects) 379

 Warning light 512

PCS (Pre-Collision System)

 Enabling/disabling the pre-collision
 system 318

 Function 316

 Warning light 511

 Warning message 315, 521

Personal lights 418

 Switch 418

 Wattage 553

PKSB (Parking Support Brake) ... 375

 Indicator 163

 Parking Support Brake function
 (rear-crossing vehicles) 384

 Parking Support Brake function
 (static objects) 379

 Warning light 512

Plug-in hybrid system 78

 AUTO EV/HV mode switch 80

 AUTO EV/HV mode 79

 Driving tips 93

 EV driving range 96

 EV mode 79

 EV/HV mode selection switch 80

 Features 78

 How to charge 128

 HV mode 79

 Hybrid battery (traction battery)
 charge mode 79

Power back door switch 197, 198

Power control unit coolant 447

 Capacity 550

 Checking 448

 Preparing and checking before win-
 ter 399

 Radiator 448

Power outlets 427

Power sources 117

**Power steering (Electric Power
Steering system) 393**

 Warning light 510

Power switch 279

 Auto power off function 282

 Changing the power switch modes
 282

If your vehicle has to be stopped in an emergency 500
 Starting the hybrid system 279
Power windows
 Catch protection function 258
 Door lock linked window operation 259
 Jam protection function 258
 Operation 258
 Window lock switch 260
Pre-Collision System (PCS)
 Enabling/disabling the pre-collision system 318
 Function 316
 Warning light 511
 Warning message 315, 521

R

Radar cruise control
 Dynamic radar cruise control with full-speed range 337
Radiator 448
RCTA (Rear Crossing Traffic Alert)
 RCTA Function 349, 366
 Warning message 350
Rear Crossing Traffic Alert (RCTA) 349
Rear fog light
 Replacing light bulbs 489
 Switch 299
Rear passengers' seat belt reminder light 516
Rear seat 250
 Folding down the rear seatbacks 251
 Head restraints 252
 Seat heaters 416
Rear turn signal lights
 Replacing light bulbs 489
 Turn signal lever 287
 Wattage 553
Rear view mirror

 Inside rear view mirror 255
 Outside rear view mirrors 256
Rear window defogger 408
Rear window wiper 302
Refueling 304
 Capacity 548
 Fuel types 548
 If the fuel filler door cannot be opened 532
 Opening the fuel tank cap 304
Regenerative braking 84
Remote Air Conditioning System 413
Replacing
 Electronic key battery 484
 Fuses 486
 Light bulbs 489
 Tires 522
 Wiper insert 481
Road accident cautions 90
Road Sign Assist 333
RSA (Road Sign Assist) 333

S

Safety Sense 306
 Automatic High Beam (AHB) 296
 Dynamic radar cruise control with full-speed range 337
 LTA (Lane Tracing Assist) 323
 PCS (Pre-Collision System) 316
 RSA (Road Sign Assist) 333
Seat belt reminder light 515, 516
Seat belts 33
 Adjusting the seat belt shoulder anchoring height 35
 Child restraint system installation 57
 Cleaning and maintaining the seat belt 435
 Emergency Locking Retractor (ELR) 35
 How to wear your seat belt 34

How your child should wear the seat belt.....	34	Side doors	191
Pregnant women, proper seat belt use	33	Side mirrors	256
Reminder light and buzzer .	515, 516	Adjustment	256
Seat belt pretensioners	35	BSM (Blind Spot Monitor).....	349
SRS warning light	510	Folding	257
Seat heaters	415	Outside rear view mirror defoggers	408
Seats		Side turn signal lights	
Adjustment precautions	249, 250	Replacing light bulbs	489
Armrest	429	Turn signal lever.....	287
Cleaning.....	435	Side windows	258
Folding down the rear seatbacks.....	251	Smart entry & start system	206
Head restraint	252	Antenna location	206
Properly sitting in the seat.....	31	Starting the hybrid system.....	279
Seat heaters.....	415	Warning message	518
Secondary Collision Brake	393	Snow tires	399
Sensor		Spare tire	
Automatic High Beam system.....	296	Storage location	523
BSM (Blind Spot Monitor)	363	Spark plug	551
Front camera.....	306	Specifications	546
Humidity sensor	413	Speedometer	166
Inside rear view mirror	255	Sport mode	388
Intrusion sensor and tilt sensor	74	SRS airbags	37
LTA (Lane Tracing Assist)	323	Steering lock	
Parking assist-sensor.....	369	Column lock release.....	280
Parking Support Brake function (rear-crossing vehicles)	363	Steering lock system warning message	280
Parking Support Brake function (static objects)	369	Steering wheel	
Radar sensor	306	Adjustment	254
Rain-sensing windshield wipers .	301	Heated steering wheel	415
RCTA.....	363	Meter control switches	172
Safety Sense.....	306	Stop lights	
Tilt sensor	74	Replacing light bulbs	489
Service plug	88	Storage feature	420
Shift lever	283	Storage precautions	421
If the shift lever cannot be shifted from P	285	Stuck	
Shift lock system	285	If the vehicle becomes stuck	543
Side airbags	37	Suggestion function	181
		Sun visors	427
		Switches	
		“ODO TRIP” switch	170

AUTO EV/HV mode switch 80
 Automatic High Beam switch 296
 Door lock switch 194
 Driving mode select switch 388
 Dynamic radar cruise control with
 full-speed range 337
 Emergency flashers switch 500
 Fog light switch 299
 Fuel filler door opener switch 305
 Heated steering wheel 416
 Ignition switch (power switch) 279
 Intrusion sensor and tilt sensor can-
 cel switch 74
 Light switch 294
 LTA switch 328
 Meter control switches 172
 Outside rear view mirror switches
 256
 Paddle shift switches 285, 286
 Parking brake switch 288
 Power back door switch 197, 198
 Power switch 279
 Power window switch 258
 Rear window and outside rear view
 mirror defoggers switch 408
 Rear window wiper and washer
 switch 302
 Seat heater switches 416
 Vehicle-to-vehicle distance switch
 337
 VSC OFF switch 394
 Window lock switch 260
 Windshield defogger switch 407
 Windshield wiper de-icer switch. 411
 Windshield wipers and washer
 switch 300

T

Tail lights

Light switch 294
 Replacing light bulbs 489

Theft deterrent system

Alarm 73
 Double locking system 72
 Immobilizer system 71
 Intrusion sensor 74
 Tilt sensor 74

Tilt sensor 74

Tire inflation pressure

Warning light 515

Tire pressure warning system

Function 454
 Initializing 465
 Installing tire pressure warning
 valves and transmitters 464
 Registering ID codes 467
 Warning light 515

Tires 452

Chains 400
 Checking 452
 If you have a flat tire 522
 Inflation pressure 471
 Replacing 522
 Rotating tires 453
 Size 552
 Snow tires 399
 Spare tire 522
 Tire pressure warning system 454
 Warning light 515

Tools 523

Top tether anchorages 60

Towing

Emergency towing 505
 Towing eyelet 505, 523
 Trailer sway control 393
 Trailer towing 270

Traction battery (Hybrid battery)

Charging 99
 Location 88
 Specification 549

Traction control 393

Traction motor (electric motor) 78

Trailer sway control..... 393
Trailer towing 270
Trail Mode..... 390
Transmission
 Hybrid transmission 283
TRC (Traction Control) 393
Trip meters 166
Turn signal lights
 Replacing light bulbs 489
 Turn signal lever 287
 Wattage 553

U

USB charging ports..... 428
Utility vehicle precautions..... 401

V

Vanity lights
 Vanity lights 427
 Wattage 553
Vanity mirrors 427
Vehicle data recordings 7
Vehicle identification number..... 546
Vehicle Stability Control (VSC).... 392
VSC (Vehicle Stability Control).... 392

W

Warning buzzers
 Approach warning 344
 Brake hold 514
 Brake Override System 514
 Brake system 508
 BSM OFF indicator 513
 Charging system 508
 Downshifting 285, 287
 Drive-Start Control 514
 Electric power steering 510
 High coolant temperature 509
 Hybrid system overheat 509

Low engine oil pressure 509
 LTA (Lane Tracing Assist)..... 323
 Open door 194
 Open hood 194
 Open window 259
 Parking assist..... 369
 Parking assist-sensor OFF indicator
 512
 PKSB OFF indicator 512
 Pre-collision warning 316
 Radar cruise control 344
 RCTA (Rear Crossing Traffic Alert)
 349
 RCTA OFF indicator 513
 RSA (Road Sign Assist) 333
 Seat belt reminder 515, 516
 Shift position..... 286, 287
 Vehicle sway warning..... 327

Warning lights

ABS 510
 Brake hold operated indicator 514
 Brake Override System 514
 Brake system 508
 BSM OFF indicator 513
 Charging system 508
 Driver's seat belt reminder light.. 515
 Drive-Start Control 514
 Electric power steering 510
 Engine 509
 Front passenger's seat belt reminder
 light 515
 High coolant temperature 509
 Hybrid system overheat 509
 Low engine oil pressure 509
 Low fuel level 515
 LTA indicator 511
 Malfunction indicator lamp 509
 Parking assist-sensor OFF indicator
 512
 Parking brake indicator 514
 PCS warning light..... 511

PKSB OFF indicator..... 512
 PKSB 512
 RCTA OFF indicator..... 513
 Rear passengers' seat belt reminder
 lights 516
 Seat belt reminder light 515, 516
 Slip indicator 513
 SRS..... 510
 Tire pressure 515
Warning messages 518
Washer
 Checking 449
 Low washer fluid warning message
 449, 518
 Preparing and checking before win-
 ter 399
 Switch 300, 302
Washing and waxing 432
Wheels 472
 Replacing wheels..... 472
Window glasses
 Power windows 258
Window lock switch 260
Windows
 Power windows 258
 Rear window defogger 408
 Washer..... 300, 302
Windshield defogger 407
Windshield wiper de-icer 411
Windshield wipers
 Position 300, 302
 Rain-sensing windshield wipers. 300
 Replacing the wiper insert..... 481
Winter driving tips 399
Wiper insert..... 481
Wireless remote control..... 189
 Battery-saving function 207
 Locking/Unlocking..... 189
 Remote Air Conditioning System 413
 Replacing the battery 484

For vehicles with multimedia system, refer to “Multimedia Owner’s Manual” for information regarding the equipment listed below.

- Audio system
- Parking assist monitor





Contact information

Country	Importers name	Registered trade name or registered trade mark	TEL. FAX	Postal address
AUSTRIA	SUZUKI AUSTRIA AUTOMOBIL HANDELS GESELLSCHAFT M.B.H.	SUZUKI AUSTRIA AUTOMOBIL HANDELS GESELLSCHAFT M.B.H.	43-642-2155 43-642-2155-390	MUNCHNER BUNDESSTRASSE 160 A-5020 SALZBURG, AUSTRIA
BELGIUM	N.V. SUZUKI BELGIUM S.A.	N.V. SUZUKI BELGIUM S.A.	32-3-4500400 32-3-4500400	SATENROZEN 8, B-2550 KONTICH, BELGIUM
BULGARIA	SFAKIANAKIS S.A.	SFAKIANAKIS S.A.	30-210-343-9927 30-210-347-6191	5, SIDIROKASTROU STR., 118 55 ATHENS, GREECE
CYPRUS	A.TRICOMITIS LTD	A.TRICOMITIS LTD	357-99-634303 357-24-63-7727	P. O. BOX 40459, STR. TIMAYIA, TRICOMITIS BUILDING, LARNACA, 7000 CY, CYPRUS
DENMARK	SUZUKI BILIMPORT DANMARK A/S	SUZUKI BILIMPORT DANMARK A/S	45-56-85600 45-56-65132	UNIONSVÆI 16, DK-4600, KOEGE, DENMARK
FINLAND	SUZUKI MOTOR FINLAND OY	SUZUKI MOTOR FINLAND OY	358-207-997-728 358-207-997-701	KAARKELIKAARI AB, 01720, VANTAA, FINLAND
Estonia	SUZUKI MOTOR FINLAND OY	SUZUKI MOTOR FINLAND OY	358-207-997-728 358-207-997-701	KAARKELIKAARI AB, 01720, VANTAA, FINLAND
Latvia	SUZUKI MOTOR FINLAND OY	SUZUKI MOTOR FINLAND OY	358-207-997-728 358-207-997-701	KAARKELIKAARI AB, 01720, VANTAA, FINLAND
Lithuania	SUZUKI MOTOR FINLAND OY	SUZUKI MOTOR FINLAND OY	358-207-997-728 358-207-997-701	KAARKELIKAARI AB, 01720, VANTAA, FINLAND
FRANCE	SUZUKI FRANCE S.A.S.	SUZUKI FRANCE S.A.S.	33-1-3483-1400 33-1-3069-7249	8, AVENUE DES FRERES LUMIERE, 78190 TRAPPES, FRANCE
GERMANY	SUZUKI DEUTSCHLAND GMBH	SUZUKI DEUTSCHLAND GMBH	49-6251-5700-380 49-6251-5700-389	SUZUKI-ALLEE 7, 66425 BENSHEIM, GERMANY
GREECE	SFAKIANAKIS S.A.	SFAKIANAKIS S.A.	30-210-343-9927 30-210-347-6191	5, SIDIROKASTROU STR., 118 55 ATHENS, GREECE
HUNGARY	MAGYAR SUZUKI CORPORATION LTD.	MAGYAR SUZUKI CORPORATION LTD.	36-33-541-317 36-33-412014	2500 ESZTERGOM SCHWEIDEL JOZSEF U.52, HUNGARY
ICELAND	SUZUKI BILAR HF	SUZUKI BILAR HF	354-566-5100 354-588-8211	SKEIFAN 17, 108 REYKJAVIK, ICELAND
ITALY	SUZUKI ITALIA S.P.A.	SUZUKI ITALIA S.P.A.	39-011-9212713 39-011-9213748	C.SO FRATELLI KENNEDY 12 30070 ROBASSOMERO (TO) ITALY
MALTA	INDUSTRIAL MOTORS LIMITED	INDUSTRIAL MOTORS LIMITED	358-21-223018 358-21-224788	1, ANTONIO BOSIO STREET, MSDA MSD 1343
NETHERLANDS	B.V. NIMAG	B.V. NIMAG	31-347-349-7112	LANGE DREEF 12 4130 EB VIANEN THE NETHERLANDS
NORWAY	RUTEBILERERNES STANDARDISERINGS AS	RUTEBILERERNES STANDARDISERINGS AS	47-32-21-88-00 47-32-82-49-53	OVRE EKERVEI 77, POSTBOKS KOOL GULSKOGEN, N-3002, DRAMMEN, NORWAY
POLAND	SUZUKI MOTOR POLAND SP. Z O.O.	SUZUKI MOTOR POLAND SP. Z O.O.	48-22-3294100	UL. POLCZYNSKA 10, 01-378 WARSAW, POLAND
PORTUGAL	SUZUKI MOTOR IBERICA S.A.U	SUZUKI MOTOR IBERICA S.A.U	34-91-151-9550	CALLE CARLOS SAINZ 35-POLOGONO, CIUDAD DEL AUTOMOVIL, 28914, LEGANES, MADRID SPAIN
SPAIN	SUZUKI MOTOR IBERICA S.A.U	SUZUKI MOTOR IBERICA S.A.U	34-91-151-9550	CALLE CARLOS SAINZ 35-POLOGONO, CIUDAD DEL AUTOMOVIL, 28914, LEGANES, MADRID SPAIN
SWITZERLAND	SUZUKI AUTOMOBILE SCHWEIZ AG	SUZUKI AUTOMOBILE SCHWEIZ AG	41-62-788-8790 41-62-788-8791	EMIL-FREY-STRASSE, 5745 SAFENWIL, SWITZERLAND
Liechtenstein	SUZUKI AUTOMOBILE SCHWEIZ AG	SUZUKI AUTOMOBILE SCHWEIZ AG	41-62-788-8790 41-62-788-8791	EMIL-FREY-STRASSE, 5745 SAFENWIL, SWITZERLAND
SWEDEN	LOUWMAN SVERIGE AB	LOUWMAN SVERIGE AB	46-8-517-323-00 46-8-28-2433	VRETNVAGEN 10, 171 54, SOLNA, SWEDEN
U.K.	SUZUKI GB PLC	SUZUKI GB PLC	44-1908-336900 44-1908-336704	STEINBECK CRESCENT, SNELSHALL WEST, MILTON KEYNES MK4 6AE, U.K.
IRELAND	SUZUKI GB PLC (IRELAND BRANCH)	SUZUKI GB PLC (IRELAND BRANCH)	353-1-414-5955 353-1-452-1796	57 BROOMHILL DRIVE, TALLAGHT INDUSTRIAL ESTATE, DUBLIN 24, IRELAND
Luxembourg	N.V. SUZUKI BELGIUM S.A.	N.V. SUZUKI BELGIUM S.A.	32-3-4500400 32-3-4500400	SATENROZEN 8, B-2550 KONTICH, BELGIUM
Slovakia	MAGYAR SUZUKI CORPORATION LTD.	MAGYAR SUZUKI CORPORATION LTD.	36-33-541-317 36-33-412014	2500 ESZTERGOM SCHWEIDEL JOZSEF U.52, HUNGARY
Czech	MAGYAR SUZUKI CORPORATION LTD.	MAGYAR SUZUKI CORPORATION LTD.	36-33-541-317 36-33-412014	2500 ESZTERGOM SCHWEIDEL JOZSEF U.52, HUNGARY
Romania	MAGYAR SUZUKI CORPORATION LTD.	MAGYAR SUZUKI CORPORATION LTD.	36-33-541-317 36-33-412014	2500 ESZTERGOM SCHWEIDEL JOZSEF U.52, HUNGARY
Croatia	MAGYAR SUZUKI CORPORATION LTD.	MAGYAR SUZUKI CORPORATION LTD.	36-33-541-317 36-33-412014	2500 ESZTERGOM SCHWEIDEL JOZSEF U.52, HUNGARY
Slovenia	MAGYAR SUZUKI CORPORATION LTD.	MAGYAR SUZUKI CORPORATION LTD.	36-33-541-317 36-33-412014	2500 ESZTERGOM SCHWEIDEL JOZSEF U.52, HUNGARY

GAS STATION INFORMATION

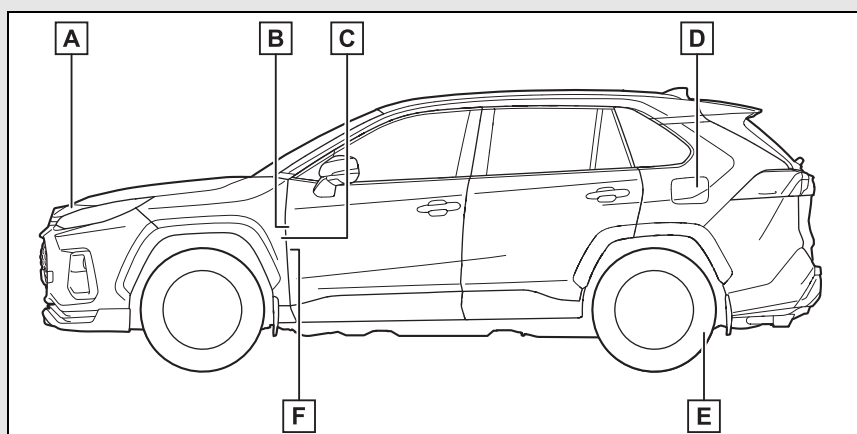

- A** Auxiliary catch lever (→P.442)
- B** Power back door switch (→P.197)
- C** Fuel filler door opener switch (→P.305)
- D** Fuel filler door (→P.305)
- E** Tire inflation pressure (→P.552)
- F** Hood lock release lever (→P.442)

Fuel tank capacity (Reference)	55 L (14.5 gal., 12.1 Imp.gal.)	
Fuel type	Unleaded gasoline only	P.548
Cold tire inflation pressure	P.552	
Engine oil capacity (Drain and refill — reference)	With filter	4.5 L (4.8 qt., 4.0 Imp. qt.)
	Without filter	4.2 L (4.4 qt., 3.7 Imp. qt.)
Engine oil type	P.549	

CHARGING STATION INFORMATION

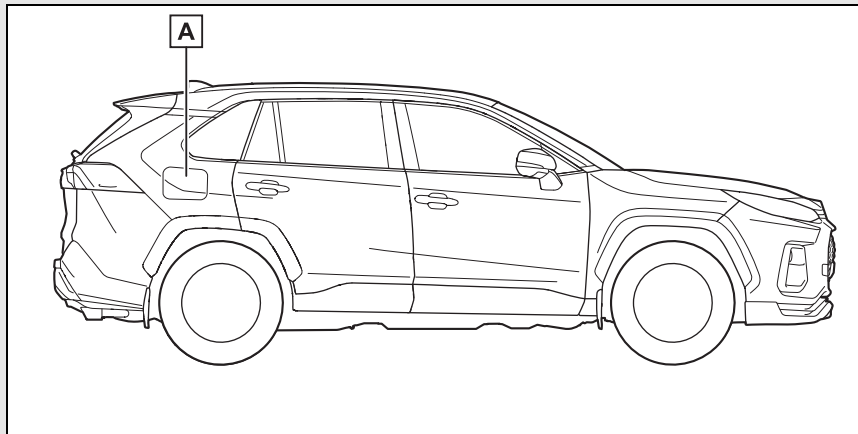

A Charging port lid

Charger type	AC charger (IEC61851-1 Mode3)
Voltage rating ^{*1}	AC 230 V 16 A
Time needed for charging ^{*2}	Approximately 5 hours
Battery type	Lithium-ion battery

^{*1}: The charging voltage may differ depending on the target region.

^{*2}: Gives an estimation of the amount of time needed to charge fully from when an EV driving range is not displayed on the multi-information display etc.
 Depending on the specifications of a charger, power supply may be interrupted before the hybrid battery (traction battery) is fully charged.
 For the charging procedure, refer to "How to charge" (→P.128).
 Handling may differ in accordance with the type of plug provided at the charging station. Check at each station.

Vehicle Data Recordings

There are certain components of your vehicle (the “Vehicle”) incorporating data storage modules or memories, which temporarily or permanently store the technical data below listed. These data are exclusively technical and serve for (i) identifying and correcting faults occurred in the Vehicle and/or (ii) optimizing functions of the Vehicle.

Recorded data (the “Recorded Data”)

- Malfunctions, faults, and errors in important system components. (e.g. lights, brakes)
- Reactions of the Vehicle in certain situations (e.g. inflation of SRS airbags, activation of stability control system).
- Operating conditions of system components (e.g. filling levels).
- Status messages of the Vehicle and its individual components (e.g. vehicle speed, acceleration, deceleration, lateral acceleration).
- Ambient conditions (e.g. outside temperature).

Recorded data vary depending on vehicle model or grade.

(For EU countries)

Parties who can read out the technical data using specific diagnostic devices (the “Parties”);

- Authorized distributors, dealers and repairers/service workshops of SUZUKI vehicles, and independent repairers/service workshops
- Manufacturer of SUZUKI vehicles (e.g. SUZUKI MOTOR CORPORATION (“SUZUKI”), Magyar Suzuki Corporation Ltd.,
- Maruti Suzuki India Limited, Suzuki Motor (Thailand) Co., Ltd., Thai Suzuki Motor Co., Ltd.)
- Suppliers of SUZUKI vehicle parts, components and accessories (the “Suppliers”)

Data usage (the “Data Usage”)

SUZUKI and the Parties may use the Recorded Data in the modules or memories for the purpose of;

- Diagnostic, service, repair and warranty processes
- Research and further vehicle developments
- Implementation of or investigation for field actions including recall and service campaign
- Quality improvements, etc.

After an error has been corrected, data related to such error are basically deleted from error storage module or memory, while certain data are overwritten or kept further.

Conditions under which SUZUKI and the Parties can disclose or provide any of the Recorded Data to a third party

SUZUKI and the Parties may disclose or provide any of the Recorded Data to a third party under any of the following conditions:

- A consent from the Vehicle owner/user(s), or from lessee of the Vehicle (in case of lease) is obtained.
- It is officially requested by police, prosecutor, court, or other authorities.
- It is provided to a research institute for statistical study after processing in such a manner that owner/user(s) of the Vehicle cannot be identified.
- It is used by SUZUKI or the Parties or their directors, officers or employees for the purposes described in the Data Usage.
- It is used by SUZUKI or the Parties in a lawsuit.
- Any other cases allowed by applicable laws and regulations.

If required, you may receive further information from each of the Parties other than the Suppliers.

NOTE:

- *The data cannot be used to detect the Vehicle's movements.*
- *The data stored in data storage modules or memories differ according to the Vehicle's grade or model.*
- *No conversation nor noise/sound will be recorded in any event.*
- *The data may not be recorded in some situations.*

If these technical data are combined with other information (e.g. accident or witness report, damage on the Vehicle, etc.), there may be cases that such data may identify a specific person.

e-Call / ERA-GLONASS

Functions added based on agreement with the customer may transmit certain vehicle data (e.g. vehicle location in emergency cases) from the Vehicle to police or emergency service official for the purpose of rescue or response to traffic accident.



SUZUKI MOTOR CORPORATION
Part No. 99011-53ZM0-01E May, 2020 英



99011-53ZM0-01E